



"ONE MILE AHEAD"

Smith and Jones

ANTIQUE AUTO PARTS

A & T PARTS 1909 - 1931

(803) 822-4141 or (803) 822-8504 - FAX (803) 822-8477

60 Wisconsin St, West Columbia, SC 29170



\$2.00

CATALOG #30

*Online ordering now
available through our website:*

www.snjparts.com

**ORDER DESK
1-800-422-1928**

2013-2014

SMITH AND JONES ANTIQUE AUTO PARTS

60 Wisconsin St, West Columbia, SC 29170
Phone: (803) 822-4141 or (803) 822-8504
FAX (803) 822-8477 – Order desk 1-800-422-1928
Established 1972

Ordering and Shipping Instructions

Please order by part numbers and descriptions in our catalog. We charge actual shipping charges due to weight, size, and destination. UPS shipping is between \$10.00 and \$20.00 for most orders. Due to UPS specifications, oversized items such as mufflers, bumpers, sheet metal, mouldings, rear fenders, etc. will be charged at the 70 pound rate. Orders that do not meet the size and weight requirements of UPS, Fed Ex, or Parcel Post will be sent by Motor Freight, collect. Minimum weight charge for Motor Freight is 100 pounds. Please use complete street addresses as UPS cannot deliver to Post Office Box addresses. Most orders shipped the same day received. Satisfaction guaranteed. **Inspect your package immediately as shipping companies will not honor any claim after a week. Save shipping box and packing if there is damage as this is a prerequisite for filing a claim. Contact us and the carrier to report damaged packages.**

Rush Orders and COD Orders: Orders Shipped within the USA ONLY

Rush orders can be sent UPS - Next Day Air or Second Day Air. UPS shipping charges are considerably higher for this service. We can send orders COD if a credit card is not available. UPS charges \$11.00, as of the printing of this catalog, per package in addition to the shipping charges.

Domestic Orders only:

USPS First Class (cheapest way) For packages weighing less than 13 oz. This method of shipping usually cost less than \$5.00.

USPS Priority Mail (faster way) This method of shipping has flat rate and regional rate boxes available ranging in price from \$6.00 to \$16.00. We try to ship packages in the best manner at the lowest cost to you!

Information on any lost or delayed Parcel Post packages can take an additional 60-90 days. We cannot reship an order that has been lost or delayed until the postal service declares the shipment a loss. The postal service does not offer a warranty on any fees involved for reshipping an order.

CUSTOMERS WHO SPECIFY PARCEL POST SHIPPING to a country not offering insurance assumes all risk for loss or damage.

Payment

Check, money order, Visa, Master Charge, Discover Card, and American Express, payable in U.S. funds. Money orders and checks should be made out to Smith and Jones Antique Auto Parts. **MINIMUM BANK CARD ORDER \$15.00 PLEASE.** All parts purchased across our counter or shipped within the State of South Carolina are subject to SC Sales Tax.

Prices

We will strive to maintain the prices in our catalog, but reserve the right to change prices without prior notice as we incur cost increases.

Returned Parts

Unaltered parts may be returned for any valid reason within 30 days of purchase. Please contact us for instructions before returning any parts. Parts returned must be accompanied by a copy of your original invoice along with an explanation of the reason for the return. **NO COD RETURNS WILL BE ACCEPTED. PARTS RETURNED MUST BE PREPAID BY THE CUSTOMER.** Items primed, painted, chromed or altered will not be returnable. A 10% restocking fee may be charged on parts returned without a valid reason or requiring repackaging for resale.

Location

Map and directions are located on the back page of the catalog.

Hours: 9 am to 5 pm, Monday through Friday. Others by appointment.

Copyright 2013 by Smith & Jones Antique Auto Parts. All rights reserved. No right to reproduce in any form without prior written permission of Smith & Jones Antique Auto Parts.

T Specifications

T 176 Cu. in 1909 1927

Comp. Ratio	4.5 to 1
Crank Journals	1.248" to 1.249"
Cylinder Diameter	3.750" to 3.751" (3 3/4")
Horsepower	20 at 1500 rpm
Stroke	4.000"

T engine serial numbers from production records . These numbers represent calendar year production, not model year.

1908 - 1-309	1918 - 2449180 - 2831426
1909 - 310-14161	1919 - 2831427 - 3659971
1910 - 14162 - 34900	1920 - 3659972 - 4698419
1911 - 34901 - 88900	1921 - 4698420 - 5638071
1912 - 88901-183563	1922 - 5638072 - 6953071
1913 - 183564 - 408347	1923 - 6953072 - 9008371
1914 - 408348 - 656063	1924 - 9008372 - 10999900
1915 - 656064 - 1028313	1925 - 10999901 - 12990076
1916 - 1028314 - 1614516	1926 - 12990077 - 14619254
1917 - 1614517 - 2449179	1927 - 14619255 - 15007033

T PARTS INDEX



	Page		Page
Accessories	26	Oil Can Holder.....	26
Battery Parts.....	32	Oil Caps.....	19
Body Blocks.....	24	Patch Panels.....	49
Body Panels.....	49	Patent Plates	32
Books.....	4, 5	Pedal Pads.....	22
Brakes.....	11	Pedal Plates.....	24
Bumper.....	32	Pickup Box Front Panel.....	50
Camshaft.....	17, 18	Pistons.....	16
Car Cover.....	45	Polish.....	148
Carburetor.....	40, 41	Radiator.....	28, 29
Carburetor Control Rods.....	23	Radiator Apron.....	27
Coil Box.....	34, 35	Radiator Caps.....	26
Connecting Rods.....	16	Radiator Shell.....	27
Cooling System.....	28, 29	Radius Rod.....	12, 13
Cowl Light Brackets.....	25	Rear Center of Body Panel.....	46
Crank.....	25	Rear End.....	8
Crankshaft.....	17, 18	Rear Hubs, Floating.....	10
Dash.....	50	Rocky Mountain Brakes.....	11
Dash Light.....	26	Ruckstell Axle.....	9
Dash Shields.....	29	Runningboards.....	36
Deck Lid.....	48	Script Plates.....	26
Distributor.....	19	Seat Frame.....	46, 47
Door.....	37	Seat Springs.....	44
Door Patch Panels.....	47	Sheet Metal.....	46, 47, 48, 49, 50
Door Sills.....	48	Side Curtains.....	45
Drive Shaft.....	10	Sill Covers (Turtle Deck).....	50
Engine Pans.....	23	Spark Plugs.....	33
Engine Gaskets.....	15	Speedometer.....	51
Engine Head.....	15	Speedster Accessories.....	53
Exhaust Manifold.....	17, 18	Speedster Kit.....	52
Exhaust Pipes.....	29	Splash Shields.....	36
Fan.....	27	Springs.....	25
Fan Belts.....	27	Starter.....	38
Fasteners.....	45	Steering Wheels.....	24
Fenders.....	50	Taillight Brackets.....	25
Firewall.....	29	Timers.....	19
Flag Sets.....	26	Tires.....	6
Flaps.....	6	Tire Covers.....	6
Floor Mats.....	51	Tool Pouch.....	141
Floorboards.....	24	Tools.....	154
Front Axle.....	12, 13	Top Boot.....	45
Gas Tank.....	14	Top Kits.....	45
Gas, Water, Oil Cans.....	26	Top Parts.....	31
Generator.....	39	Transmission.....	20, 21, 22
Handbrakes.....	22	Trunk Floor.....	47
Hoods.....	30	Tubes.....	6
Horn.....	31	Upholstery Kits.....	45
Ignition Switch.....	35	Valve Stem Covers.....	6
Interior Trim Screw Sets.....	44	Valves.....	17, 18
License Plate Brackets.....	25	Videos, How to.....	5
License Plate Frame.....	26	Water Pumps.....	28, 29
Lights.....	42	Wheels.....	12, 13
Magnetic Decal.....	26	Windshield Frames (Open Cars).....	43
Magneto.....	20, 21, 22	Windshield Parts.....	43
Mirrors.....	44	Windwing Bracket.....	26
Motormeters.....	26	Wiring.....	33
Mufflers.....	29	Wood.....	7
Noise Makers.....	31, 141	Year Plates.....	26



	Page
Accessories.....	114
Additives.....	149
Air Maze.....	86
Alternator.....	87
Ammeter.....	87
Axle, Front.....	64
Axle, Rear.....	69
Battery and Battery Support Assembly.....	71
Body Blocks, Pad & Webbing.....	70
Body Patch Panels.....	104, 105
Body Styles.....	148
Body Wood Bolt Set.....	137
Bolt Kits & Clinch Nuts.....	143
Books.....	54, 55, 56
Beauty Rings.....	59
Brake Drum, Cast Iron.....	57
Brakes and Brake Related.....	61, 62
Bumpers.....	111
Bumper Arms, Front.....	111
Bumpers, Clamps.....	110
Carburetors.....	85, 86
Carpets, Deluxe.....	144
Chassis.....	70
Chassis Springs & Related Items.....	72
Clutch.....	79
Coil.....	90, 91
Cooling System.....	79, 80, 81
Cotter Pins.....	143
Cover, Car.....	84
Cowl Lights.....	94
Cut Out.....	87
Dash Panel.....	88
Dash Rail.....	88
Data Plates.....	114
Differential.....	69
Distributor.....	90, 91
Dome Light.....	88
Door Bottom Patch Panels.....	105
Door Bumper Sets.....	144
Door Check Straps.....	132
Door Handle & Door Handle Pads, Outside.....	136
Door Hinges.....	130
Door Seals.....	128
Door Sill Plates.....	133
Dove Tails.....	131
Drive Shaft.....	69
Engine.....	152
Engine Cams.....	73
Engine Gasket Sets.....	73
Engine Heads and Head Gaskets.....	73
Engine Parts.....	73, 74, 75, 76

	Page
Emergency Brake.....	63
Escutcheons.....	129
Exhaust Manifold.....	84
Fan.....	81
Fan Shroud.....	79
Fenders (Fiberglass).....	105
Fenders (Steel).....	103
Fender Braces.....	101
Fender Covers.....	102
Fender Patch Panels.....	104
Fender Well.....	101
Filler Trim.....	126
Floor and Floorboards.....	116
Floor Mats.....	144
Front Axle.....	64
Front Bumper Arms.....	111
Front Radiator Splash Shield.....	105
Fuel System.....	82, 83
Garnish Moulding (Fiberglass).....	128
Garnish Moulding (Metal).....	129
Gas Cap.....	82
Gas Gauge Parts.....	83
Generator.....	87
Glass.....	148
Glass Bedding Channel.....	127
Grease Fittings & Grease.....	142
Handles, Inside door & window.....	129
Handles, Outside.....	136
Hats.....	84
Headers.....	137
Headlights.....	92, 93
Hood.....	106
Horns.....	98
Horn Rods.....	68
Hub Caps.....	57
Hydem Welt.....	123
Ignition Switch.....	88
Information (Body styles).....	148
Insulation.....	153
Intake Manifold.....	84
Interior Trim Screw Set.....	143
Kick Panels.....	146
License Bracket.....	96
License Plate Frames.....	95
Light Switch.....	68
Lights.....	92, 93
Lubricants.....	149
Luggage Rack.....	115

A PARTS INDEX



	Page		Page
Manifold.....	84	Spare Tire Parts.....	58
Metal Valve Stems.....	60	Spark and Carburetor Controls.....	86
Mirrors.....	109	Spark and Gas Rods.....	68
Miscellaneous Door Parts.....	130, 131	Spark Plugs.....	91
Motormeters.....	114	Speedometer.....	107
Motor Mounts.....	70	Speedster Kit.....	150
Muffler.....	71	Splash Shield, Radiator.....	105
Nails.....	148	Spoke Covers.....	59
Noise Makers.....	31, 142	Starter.....	89
Novelty Items.....	114	Steering.....	65, 66, 67
Oil Filter.....	77	Steering Shaft.....	65
Oil Pump.....	76	Steering Wheel.....	68
Overflow Pipe.....	80	Step Plates.....	102
Paints.....	149	Stone Guards.....	115
Patch Panels, Body.....	104, 105	T-Shirts.....	84
Patent Plate.....	114	Tail lights.....	95, 96, 97
Pedal Covers.....	112	Tie Rods.....	64
Pickup Truck.....	120, 121, 135	Tire Bands.....	59
Piston Rings & Pistons.....	74	Tire Irons.....	59
Plugs, Spark.....	91	Tire Pump.....	59
Polish.....	149	Tires.....	60
Posters.....	56	Tool Pouch.....	142
Pressure Plates.....	79	Tools.....	154
Quails.....	114	Top Kits.....	146
Radiator.....	79	Top Parts.....	123, 124
Radiator Caps.....	80	Top Irons.....	139
Radiator Shells.....	80	Top Wood Bolt Sets.....	139
Rear Axle.....	69	Transmission.....	77, 78
Regulator, Voltage.....	87	Truck, Model AA - 1 Ton.....	151
Restoration Supplies.....	143, 149	Trunks.....	115
Rims.....	60	Tubes.....	60
Rivets.....	143	Upholstery.....	145, 146, 147
Roadster Body.....	120	Wallpaper Border.....	114
Rods, Engine.....	74	Water Pump.....	81
Rumble Seat Parts.....	122	Webbing, Body.....	70
Running Board Braces.....	101	Welt, Fender.....	101, 103
Running Board Shields.....	102	Wheels.....	57
Running Board Trim.....	102	Window Regulator and Glass Channel & Weather Stripping....	127, 128
Running Boards.....	101	Windshield.....	125, 126
Seals and Bearing for Wheels.....	57	Windshield Glass.....	148
Seat Adjustment Parts.....	134	Windshield Wipers.....	108
Seat Springs.....	140, 141	Windwing Brackets.....	113
Sealer, Gas Tank.....	149	Windwing Glass.....	113
Sheet Metal.....	117, 118, 119, 120, 121	Wiring.....	99, 100
Shock Absorbers.....	112	Wood Parts.....	137, 138, 139
Side Curtains.....	146	ORDER BLANKS.....	157, 159
Side Curtain Rods.....	139		

Books



NUMBER	NAME OF PART	PRICE	NUMBER	NAME OF PART	PRICE
BR-1	1909-27 THE RUCKSTELL AXLE. A very comprehensive 35 page book published by The Model T Ford Club of America. It is a very comprehensive guide for the repair and restoration of the Model T Ford Ruckstell axle.	12.00	C-5	Historical Model T Scrapbook by Floyd Clymer. 212 pages filled with sales literature, accessories, etc. for the tin lizzie	20.00
BT-A	Model T Owner's Supply Book. Information on accessories and replacement parts. 128 pages	24.00	E-1	FROM HERE TO OBSCURITY. A very detailed book covering Model T's from 1909-27. It has numerous pictures denoting different cars & production changes.	43.50
BT-AX	A detailed and comprehensive book for repairing and restoring the Model T Ford front and rear axles	12.00	LR-1	1909-27 Ruckstell Axle Service Manual. 12 pages and 35 illustrations on basics of service, repair and maintenance of the ruckstell axle.	6.00
BT-C	1909-27 THE FORD CARBURETOR. This 48 page book from The Model T Ford Club of America covers repairing and restoring the Model T Ford carbs. Very good detail!	12.00	LR-2	1909-27 Ruckstell Axle Operating Instruction Booklet. Came with newly purchased units, tells you how to shift.	5.00
BT-E	A detailed guide for the repair of the Model T Electrical System. 48 pages.	12.00	LR-4	1909-27 Large reprint of original Ruckstell Axle assy.	6.00
BT-J	Model T Judging Guidelines	38.00	LR-5	1909-27 Ruckstell Lubrication and Adjustment of the Ruckstell Axle. Explains how to shift as well as general knowledge of the ruckstell axle.	6.00
BT-M	A Comprehensive Guide for the Repair and Restoration of the Model T Ford Engine. 54 pages	12.00	PT-7	MODEL T SERVICE BULLETINS. Hardback copy of over 500 pages of information sent to dealers by Ford advising them how to repair & sell the Model T.	39.00
BT-S	Speedometer book by the Model T Ford Club of America. Used in identifying and restoring the Model T Speedometer.	12.00	P-8	The Fast Ford, Secrets of Speed. 528 pages, 800 illustrations, covers chassis, motor, etc. 100 chapters from Old Ford Owner Monthly	25.00
BT-SC	Stromberg Model T carburetor installation & adjustment instruction booklet as came with the carburetor	5.00	P-9	MODEL T OWNER	39.00
BT-T	A detailed guide for the repair of the Model T Transmission 50 pages.	12.00	P-10	Model T Ford in Speed and Sport. 224 pages of authoritative speed & sport conversion info	25.00
BT-19	Tinkering Tips - Vol. I, 134 pages, by Ted Aschman	20.00	T-1	MODEL T FORD SERVICE BOOK. In our opinion the best book for Model T Repair.	37.00
BT-20	Tinkering Tips by Ted Aschman, compiled from "Do it Yourself" articles from the Vintage Ford Magazine and the author. A lot of the information is not available in other books. Vol. II	20.00	T-2	1909-15 MODEL T OWNER'S MANUAL. Came with the T when new to tell the owner how to operate and maintain it.	7.00
C-4	MODEL T MEMORIES, Informative book on the Model T with production changes & numbers, jokes, and Model T stories from the Model T era	23.75	TT-8 CD	CD contains transmission information, body styles & TT information	20.00 ea.
			TT-8	Model T one ton truck chassis & body price list book	5.35 ea.
			POST VI	Model T Lubrication Chart shows lubrication points and frequency of lubrication	8.25 ea.

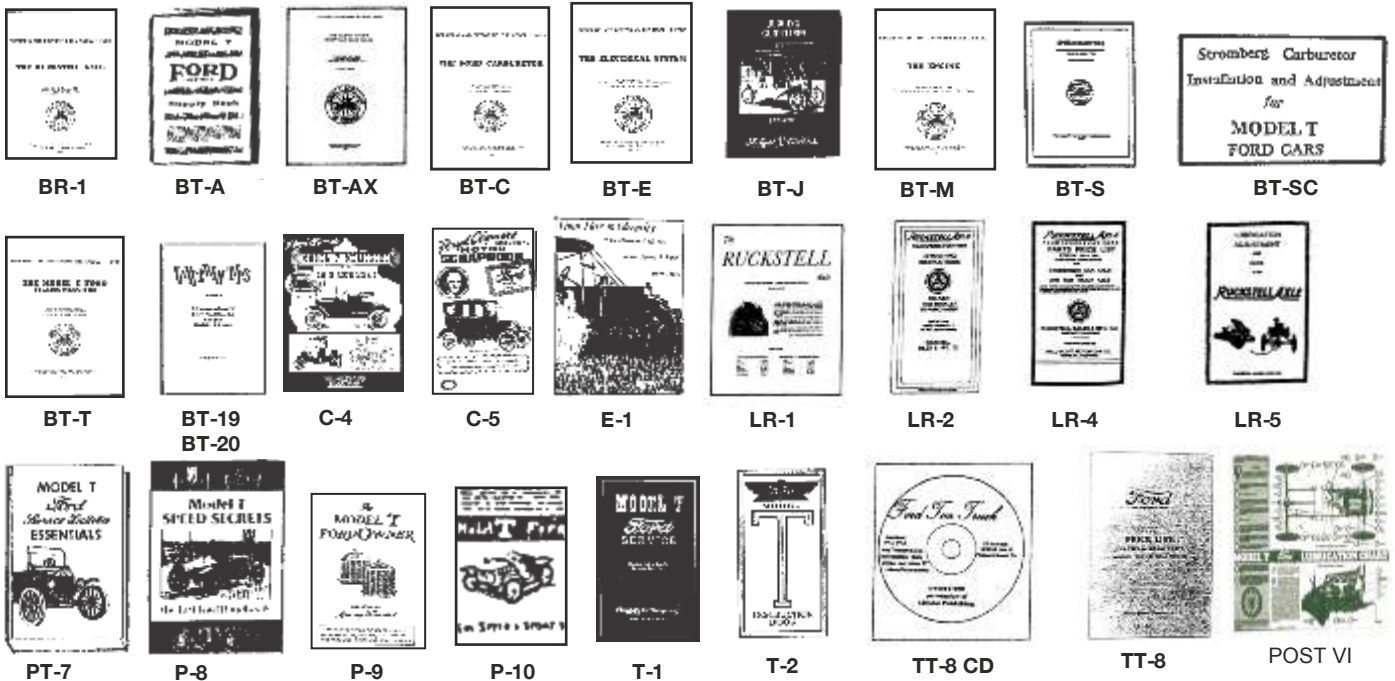

Books



NUMBER	NAME OF PART	PRICE	NUMBER	NAME OF PART	PRICE
T-3	1915-25 MODEL T OWNER'S MANUAL. Came with the T when new to tell the owner how to operate and maintain it.	13.50	T-13	Model T Ford by Bruce McCalley. Full story of the Model T Ford from 1908-27. Perfect for collectors and restorers. 600 pages with 1300 illustrations.	Disc.
T-4	1926-27 MODEL T OWNER'S MANUAL. Came with the T when new to tell the owner how to operate and maintain it.	13.50	T-14	1915-27 Model T windshield and glass specifications, diagrams and dimensions. 14 pages, 47 illustrations	7.00
T-5	1909-15 CHASSIS PARTS LIST	8.50	T-15	Rebuilding the Model T Power Plant - Comprehensive book on rebuilding the Model T Ford Engine	Disc.
T-6	1916-21 CHASSIS PARTS LIST	8.50	103	Hassler's Shock Absorbers & Parts	1.50
T-7	1923-27 CHASSIS PARTS LIST	13.50	104	Hassler Shock Installation Booklet	1.50
T-9	1923 BODY PARTS LIST	10.00	105	Delco Distributor Instruction Booklet	3.00
T-9A	1909-23 Price list of parts T and TT. 36 pages	2.00	T-FIRE	Firefighting w/Henry's Model T	24.95
T-10	1926-27 BODY PARTS LIST	13.50			
T-12	One of the first Model T Restoration Handbooks written	37.00			

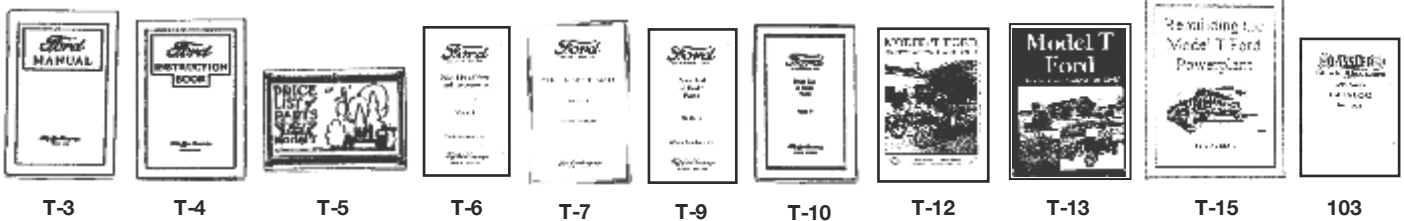

How To Videos

NUMBER	NAME OF PART	PRICE	NUMBER	NAME OF PART	PRICE
T1-1	Balancing Tires - Using modern weights to balance the tires on your Model T - a must for anyone driving a Model-T over 35 mph. 16 min.	12.00	T2-4	Restoring the "T" Transmission - Part I - Disassembly tools needed, cleaning, inspecting, methods of checking for cracks, plus tips and suggestions. 42 min.	12.00
T1-2	Model T Tires - Part I - Covers the types of rims and tires used on Model T's; tools and tips on repairing rims and mounting tires, how to mount a tire on a clincher rim. 26 min.	12.00	T2-5	Restoring the "T" Transmission Part II - Balancing the transmission, tools and special jigs, re-assembly secrets, lubrication, repair techniques, old and new clutch plates, critical Measurements and testing, plus tips and suggestions. 53 min.	12.00
T1-3	Model T Tires - Part II - Covers building a tire mounting station; mounting tire on the drop center-type and split rim-type rim; tools and tips on repairing rims. 24 min.	12.00	T3-1	Model T Coils I - A general overview of the evolution of the coil in the Model T. Do you know which coil is the proper coil for your Model T? This video cover both the Ford made coils as well as those produced for Ford by other manufacturers. 22 min.	12.00
T1-4	The Model T Fuel Filter - Restoring the different types of Model T fuel filters; installing modern fuel line shut-off valves. 15 min.	12.00	T3-2	Model T Coils II - Repair and rebuilding a coil. How it works. How to select a coil to rebuild. Tips and tricks of coil rebuilding. 40 min.	12.00
T1-5	Model T Bands - Changing the transmission band linings. Covers the types of transmission bands and linings available; inspecting and restoring bands; adjusting bands; tips and tools needed. 15 min.	12.00	T3-3	Model T Coils III - How to adjust your coils for maximum performance. What to look for when installing new points. Testing your coils. An overview of various coil testing machines available during the Model T era. 38 min.	12.00
T2-1	Restoring the Transmission (Hogshead) Cover - Types of hogsheads, tools and tips, disassembly pedal straightening, pedal alignment, O-rings, sealing techniques, and assembly. 20 min.	12.00	T3-4	Restoring the Generator - Covers the Model T generator-how it works, how to repair and rebuild it. Includes tips and tricks for disassembly and assembly as well as equipment used in testing. 31 min.	12.00
T2-2	Restoring the 'T' Cutout - Types of cutouts. Function of the cutout. Testing selecting, disassembly, modernizing with a diode, assembly and testing. 38 min.	12.00	T3-5	How the starter works, how to test and rebuild your starter motor. Also includes tips on eliminating oil leaks, removing and installing in your Model T. 19 min.	12.00
T2-3	Alignment - Tools needed, special era tools used, how to align using a tape measure, front end inspection, proper caster, camber and toe-in of the front end for early and late Ts. Also tips on rear end alignment. 23 min.	12.00			

* Ask about DVD's for all VHS tapes listed above 14.00 ea.

Tire Covers



Made from leatherette, one piece circle, no splices. Silk screened Ford emblem. Welted seam outer edge.

NUMBER	NAME OF PART	PRICE
*T-1395 A1	Black Model T 30 x 3 1/2	33.00
*T-1395 A2	Tan Model T 30 x 3 1/2	33.00
*T-1395 B1	Black Model T 21	33.00
*T-1395 B2	Tan Model T 21	33.00

T-1500 T 4



T-1505 C



T-1500 T 5



T-1506 REB
T-1506 REC

Tires

NUMBER	NAME OF PART	PRICE
T-1500 T2	30 x 3 Excelsior Tire	179.00
T-1500 T4	30 x 3 1/2 Excelsior Tire	189.00
T-1500 T5	30 x 3 1/2 Universal Tire	155.00
T-1500 T6	30 x 3 1/2 Firestone Tire	180.00
T-1500 T7	30 x 3 Universal Tire	155.00
T-1500 T8	30 x 3 Firestone Tire	172.00
T-1500 T9	30 x 3 1/2 Wards Riverside Tire	152.00
T-1500 T10	30 x 3 Wards Riverside Tire	151.00

*See Model A section for 21" tires.

Tubes

NUMBER	NAME OF PART	PRICE
T-1505 A	30 x 3 Tubes, Rubber Stem	15.50
T-1505 B	30 x 3 1/2 Tubes, Rubber Stem	15.50
T-1505 C	21" Tubes, Rubber Stem	15.50
T-1505 AT	30 x 3 Metal Stem Tubes for wood wheels	32.50
T-1505 BT	30 x 3 1/2 Metal Stem Tubes	32.50
T-1505 CT	21" Tubes with 3 1/2" brass stems for wood spoke wheels	32.50

Valve Stem Covers

NUMBER	NAME OF PART	PRICE
T-1502 AC	Nickel Dust Cover for Wood Wheels	14.50 ea.
T-1502 AN	Nickel Reducer Nut for Stem Cover	8.50 ea.
T-1502 BC	Brass Dust Cover for Wood Wheels	9.50 ea.
T-1502 BN	Brass Reducer Nut for Stem Covers	8.50 ea.
T-1506 REB	1909-27 Brass adjustable stem cover. Fits rubber stem tubes.	17.95 ea.
T-1506 REC	Same as T-1506 REB except nickel plated.	17.95 ea.

Flaps

NUMBER	NAME OF PART	PRICE
T-1507 F1	21" Flap for Split Rim	28.00
T-1507 F3	23" Flap for 30 x 3 1/2 Rim	28.00
T-1507 F4	24" Flap for 30 x 3 Rim	28.00

Wood

Door Wood

NUMBER	NAME OF PART	PRICE
TWD-1220-4	1914 Roadster and Touring right front door wood	150.00
TWD-1229-4	1920-23 Coupe (Suicide Doors)	670.00
TWD-1230-4	1914-25 Coupe	618.00
TWD-1243-4	1915-25 Roadster & Touring right front door (included in body wood kits)	150.00
TWD-1246-4L	1914-25 Touring left rear door (included in body wood kit).	177.00
TWD-1246-4R	1914-25 Touring right rear door (included in body wood kit).	177.00

Seat Tack Rails

(Included in body wood kits)

NUMBER	NAME OF PART	PRICE
TWD-1220-2F	1914 Touring front tack rail	206.00
TWD-1220 2R	1914 Touring rear tack rail	206.00
TWD-1234-2	1922-Early 23 Roadster heavy tack rail (5 pieces)	110.00
TWD-1243-2	1923-25 Roadster tack strip (7 pieces)	112.00
TWD-1244-2	1926-27 Roadster tack strip (6 pieces)	110.00
TWD-1245-2F	1921-25 Touring front tack rail (7 pieces)	127.00
TWD-1245-2R	1921-25 Touring rear tack rail (5 pieces)	111.00
TWD-1246-2F	Late 25 Touring front tack rail (7 pieces)	127.00
TWD-1246-2R	Late 25 Touring rear tack rail (5 pieces)	111.00
TWD-1247-2F	1926-27 Touring front tack strip (2 pieces)	111.00
TWD-1247-2R	1926-27 Touring rear tack strip (3 pieces)	127.00

Top Wood

NUMBER	NAME OF PART	PRICE
TWD-1236	1923-25 Fordor sedan top wood	480.00
TWD-1238	1926-27 Tudor sedan top wood	488.00
TWD-1239	1923-25 Coupe top wood	405.00
TWD-1240	1926-27 Coupe top wood	379.00
TWD-1241	1926-27 Fordor sedan top wood	488.00
TWD-1242	1924-25 Tudor sedan top wood	488.00
TWD-1252	1920-23 Coupe top wood	405.00

Body Wood

NUMBER	NAME OF PART	PRICE
TWD-1220	1914 Touring with door wood	2,400.00
TWD-1229	1920-23 Coupe	2,905.00
TWD-1230	1924-25 Coupe	2,335.00
TWD-1231	1926-27 Coupe	177.00
TWD-1243	1923-25 Roadster (includes door wood)	1,305.00
TWD-1244	1926-27 Roadster	235.00
TWD-1245	1921-22 Touring (includes door wood)	1,855.00
TWD-1246	1923-25 Touring (includes door wood)	1,855.00
TWD-1247	1926-27 Touring	465.00
TWD-1248	1926-27 Tudor	125.00
TWD-1249	1916-27 Fordor sedan	2,205.00

Miscellaneous Wood

NUMBER	NAME OF PART	PRICE
TWD-1650 R	1926-27 Tudor right front seat bottom	69.50
TWD-1650 L	1926-27 Tudor left front seat bottom	62.50
TWD-1651	1926-27 Tudor rear seat cushion	98.50
TWD-1652	1926-27 Tudor rear seat backrest	109.00
T-3083	1909-27 Crankcase arm blocks (pair)	3.00

Open Car Top Wood Bows

NUMBER	NAME OF PART	PRICE
T-7942 A	1917-22 Roadster	67.00
T-7942 B	1923-25 Roadster	67.00
T-7942 C	1926-27 Roadster	67.00
T-7942 D	1917-22 Touring	85.00
T-7942 E	1923-25 Touring	85.00
T-7942 F	1926-27 Touring	92.00

Rear End

* Original Licensed Product
Ford Motor Company



M-600 Q



T-2504 S



T-2505



T-2505 SH



T-2506



T-2508



T-2508 AO
T-2508 AI



T-2509
T-2509 OR

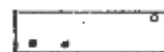

T-2509 SP



T-2510



T-2510 A



T-2510 B



T-2510 C



T-2511



T-2511 S



T-2511 RE



T-2518/24 AS



T-2519 A



T-2521



T-2528



T-2528 NB



T-2529



T-2531B

T-2532



T-2532 G



T-2545

T-2545 BR



T-2518 SHA



T2529 SHA



T2510 BM

NUMBER	NAME OF PART	PRICE	NUMBER	NAME OF PART	PRICE
M-600 Q	600 w gear oil, heavy clinging type	7.95 qt.	T-2511 RE	1909-27 Leather seal kit with spring washers. Started in 1927. Can be used on all years. (6 pc.)	6.50 set
M-600 G	600 w gear oil, heavy clinging type	29.00 gal.	T-2511 S	1909-27 Modern Day Rear Axle Seal. Installed behind rear axle bearing & sleeve to prevent leaks. Neoprene boot type seal.	17.50 pr
T-2504 S	1911-27 Rear end U-joint gasket set	3.95	T-2518 SHA	1909-27 Ring gear shim .010, not used originally but sometimes helpful in compensating for wear	6.25
T-2505 HS	1912-27 Axle shaft made from 4140 alloy steel and 1/16" longer to help with worn hubs and more clearance with floating hubs	110.00	T-2518/24	1911-27 11-40 Ring and pinion set. Made to Ford blueprint	360.00
T-2505 SH	1909-27 Rear axle/hub shims	1.80 pr.	T-2518/24 AS	1911-27 11-40 Ring gear and pinion	350.00
T-2506	1909-27 Axle shaft washer, a tough fibre disc that fits between axle shafts in differential	.70	T-2518/24 BS	1911-27 3:1 Ring gear and pinion	325.00
T-2507	1909-27 Castellated nut for holding hub to axle	1.45 ea.	T-2519 A	1909-27 Differential lock ring. 2 pc.	1.00
T-2508	1911-27 Rear axle bearing	14.50	T-2521	1911-27 Differential gear key	1.50
T-2508 AO	1909-27 Accessory Modern day rear axle outer wheel bearing & sleeve assembly with sealed outside bearing. Replaces old roller bearing & sleeve. Two required	168.00 ea.	T-2526 B	Used Differential spider for rear end	16.00
T-2508 AI	1909-27 Accessory modern day rear axle inner bearing & sleeve assembly. Replaces old roller bearing & sleeve. Two required.	107.00 ea.	T-2528	1909-27 Differential thrust washer. Two required. Brass	11.00 ea.
T-2509	1911-27 Right rear axle bearing sleeve, economy	10.50	T-2528 NB	Differential roller thrust bearing set. Replaces T-2528 & T-2529. Reduces friction. 2 sets required.	36.00 set
T-2509 B	1911-27 Left rear axle bearing sleeve, economy	10.50	T-2529	1909-27 Differential thrust plate. Four required.	5.95
T-2509 OR	1912-27 Right rear hardened axle bearing sleeve. Made to original blueprints.	18.00	T-2529 SHA	Thrust washer shim, .010	3.50
T-2509 ORB	1912-27 Left rear hardened axle bearing sleeve. Made to original blueprints.	18.00	T-2531 B	1917-27 Differential thrust plate pins	.75
T-2509 SP	1909-27 Model T bearing sleeve puller	13.95	T-2532	Differential Plug (See also B-6730 M magnetic)	1.95
T-2510	1909-27 Rear axle housing bearing cap	2.00 ea.	T-2532 G	Differential Plug Gasket	.25
T-2510 A	1909-27 Rear axle bearing washer	.80 ea.	T-2545	1909-27 Steel grease cap. 1/8" pipe thread for rear axle and drive shaft bushing.	3.50
T-2510 AM	1909-18 Replaces T-2510 A & B. Improves outer grease seal. Made of aluminum, keeps grease in.	43.00 pr.	T-2545 B	1909-27 Small steel grease cup with modern ball zerk fitting installed	6.75
T-2510 B	1909-27 Outer felt bearing seal	.80	T-2545 BM	1909-27 Small brass grease cup with modern ball zerk fitting installed.	8.75
T-2510 BM	1918-27 Same as T-2510 AM	43.00 pr.	T-2545 BR	1909-27 Brass grease cap. 1/8" pipe thread for rear axle.	6.75
T-2510 C	1909-27 Inner felt seal	1.50			
T-2511	1909-27 Leather seal	5.50 pr.			

Ruckstell Axle

* Official Licensed Product
Ford Motor Company

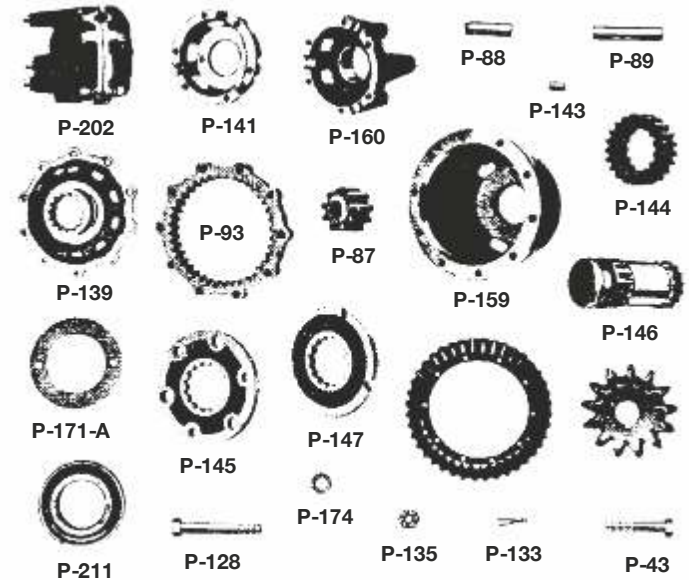
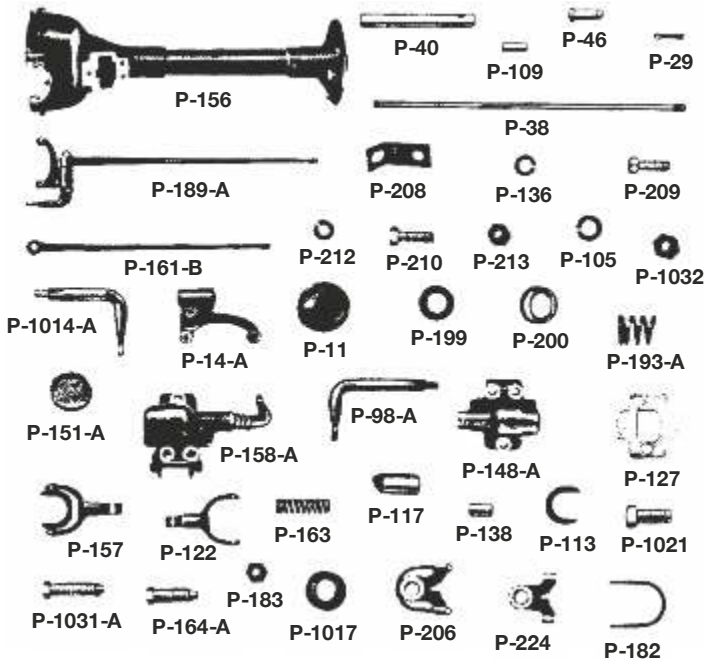
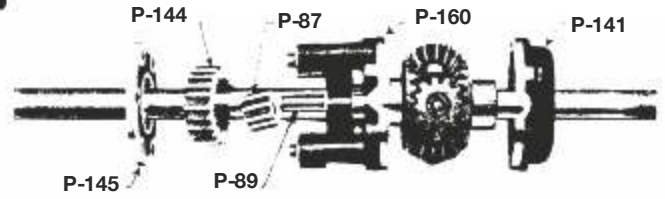
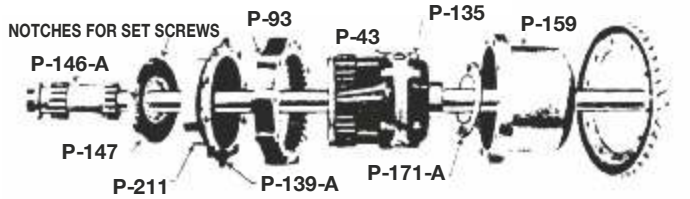

NOT ALL ITEMS PICTURED ARE AVAILABLE!

NUMBER	NAME OF PART	PRICE
*T-2501 ARUX	1920-25 Ruckstell Axle Kit	\$2,130.00
	All the parts needed to convert your standard axle to a Ruckstell 2 speed axle.	
*T-2501 BRUX	1926-27 Ruckstell Axle Kit	2,240.00
	All the parts needed to convert your standard axle to a Ruckstell 2 speed axle.	
*Ruckstell kits are sold with a good Ford left axle housing in exchange.		
P-11 RK	Shifter Knob, "Ruckstell"	5.00
P-14A	Ruckstell shift lever bracket	16.00
P-38	Shift rod, original type	70.00
P-38 A	Shift rod with adjustable clevis	80.00
P-43/135S	Nut & bolt set for P-202	13.75
P-87	Pinion gear set (3)	80.00
P-89	Pin set, pinion gear (3)	24.25
P-93	Internal ring gear	170.00
P-98 A	Shift lock arm (13-25)	39.50
P-98 C	Shift lock arm (26-27)	38.50
P-113	Shift lock clevis (part of P-158 A)	55.00
P-117	Plunger (part of P-158 A) (13-25)	26.00
P-117 B	Plunger & roller assembly (26-27)	37.00
P-117 BR	Pin & roller (part of P-117 B)	13.25
P-122	Shift Yoke (part of P-158 A)	65.00
P-127	Gasket (for P-158 A and P-158 C)	2.10
P-128 S	Ring gear bolt & washer set (10)	60.00
P-138 S	Pin set (2) (for P-113/P-122)	2.25
P-139	Bronze thrust plate	160.00
P-141	Diff. housing, right (part of P-202)	102.00
P-143	Thrust washer pin (for P-159) (Need 2)	1.75

NUMBER	NAME OF PART	PRICE
P-144	Sun gear	75.00
P-145	Steel thrust plate, gear locking	105.00
P-146	Sliding clutch gear	102.00
P-147	Notch plate, gear locking	102.00
P-148 A	Shifter housing (for P-158 A) (13-25)	102.00
P-156	Axle housing, Ruckstell (13-25)	500.00
P-156 C	Axle housing, Ruckstell (26-27)	510.00
P-157	Shifter yoke & clevis assembly	Disc.
P-158 A	Shift lock assy. (13-25) (also fits 26-27)	280.00
P-158 C	Shift lock assy. (26-27)	420.00
P-158 BS	Mounting bolt set (for P-158, brass body)	10.95
P-158 A-BS	Mounting bolt set (for P-158 A, cast iron)	13.00
P-158 C-BS	Mounting bolt set (for P-158 C, large 26-27)	13.00
P-158 CRS	Shift fork pin & roller set (26-27)	14.25
P-158 CP	Spring tension adj. plug (26-27)	5.25
P-159	Ring gear support (bell housing)	115.00
P-160	Diff. housing, left (part of P-202)	150.00
P160 BS	Bronze bushing set (3) (to repair P-202)	12.50
P-163	Tension spring (for P-117)	5.25
P-163 B	Tension spring (for P-117 B)	5.50
P-164 A	Locking set screw & nut, top (for P-147)	5.50
P-189 A	Shift lever & knob	165.00
P-189 B	Shift lever & knob for ruckstell axle.	
	Left hand shift	65.00
P-193 A	Shift lock arm spring (for P-98 A & P-98)	5.00
P-200	Cup washer (for P-98 A & P-98 C seal)	4.50
P-202	Diff. assembly (P-160, P-141 & P-43/135 S)	250.00
P-206	Shift rod support	15.00
P-211	Ball bearing	105.00

Drive Shaft

* Original Licensed Product
Ford Motor Company

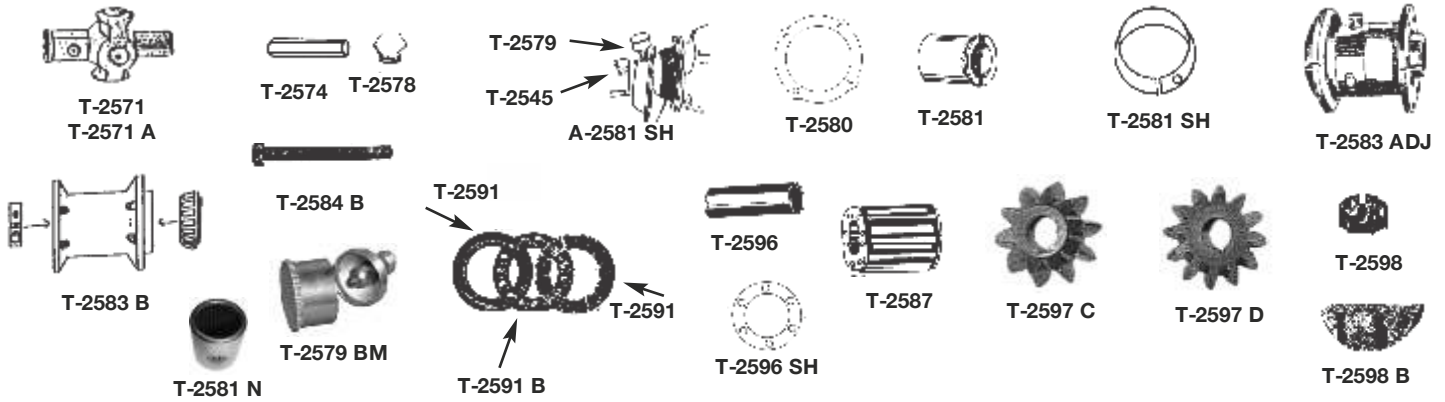

NUMBER	NAME OF PART	PRICE	NUMBER	NAME OF PART	PRICE
T-2571	1909-27 Rebuilt universal joint Exchange only	Disc.	T-2583 B	1922-27 Modern day pinion bearing assembly. Exchange only, must have your old core. Replaces old style roller & thrust bearing w/modern tapered bearings.	115.00
T-2571 A	1909-27 New manufacture U-Joint	97.00	T-2583 E1	1909-21 Pinion bearing assembly with modern bearings (\$50.00 core charge)	116.00
T-2574	1909-27 Universal joint pin	.45	T-2584 B	1912-27 Drive shaft roller bearing housing bolt	3.35 ea.
T-2578	1909-27 Universal Joint Plug flathead	1.75	T-2587	1911-27 Drive shaft roller bearing	32.00
T-2579	1909-27 Universal joint grease cup (steel)	7.60	T-2591	Drive shaft thrust collar, 2 required	13.00
T-2579 B	1909-27 Universal joint grease cup (brass)	9.00	T-2591 B	Drive shaft thrust ball bearing retainer assy. 1920-27	13.50
T-2579 BM	1909-27 Brass universal joint cup with zerk fitting.	14.00	T-2595	1909-27 New Drive shaft - USA	130.00
T-2579 M	1909-27 Steel universal joint cup with zerk fitting.	9.50	T-2596	1909-27 Drive shaft sleeve	18.50
T-2580	1909-27 Ball joint gasket	1.00 ea.	T-2596 SH	Drive shaft pinion gasket shim	.40
T-2581	1909-27 Drive shaft front bushing	9.55	T-2597 C	10 tooth pinion gear, 4/1 gear ratio when used with Ford 40 tooth ring gear.	145.00
T-2581 N	1909-27 Drive shaft roller bearing	22.00	T-2597 D	12 tooth pinion gear 3.25/1 gear ratio when used with original ruckstell 40 tooth or modern ruckstell 39 tooth ring gear.	145.00
T-2581 SH	1909-27 Universal joint shim. Used to take out play between ball cap and housing.	5.00	T-2598	1911-27 Drive shaft castle nut	2.85
T-2583 ADJ	1920-27 Drive shaft pinion bearing housing assembly with modern tapered bearing and external adjustment to set pinion bearing clearance.	175.00	T-2598 B	1911-27 Drive shaft pinion key	1.50

Floating Rear Hubs

NUMBER	NAME OF PART	PRICE
T-2887	1909-27 Floating rear hubs for wood wheels that replaces old roller bearing and transfers the weight of the car to the axle housing. The axle housing requires modification. Two hubs required. (6 bolts and 6 nuts included)	240.00 ea.
T-2887 W	1926-27 Floating rear hubs for wire wheels that replaces the old roller bearings and transfers the weight of the car to the axle housing instead of the axle. The axle housing will require modification. Two hubs required.	240.00 ea.

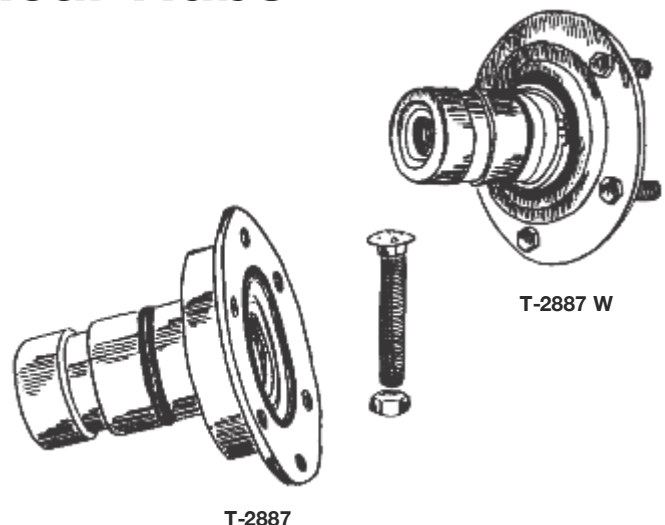

Brakes

* Official Licensed Product
 Official Licensed Product
 Official Licensed Product

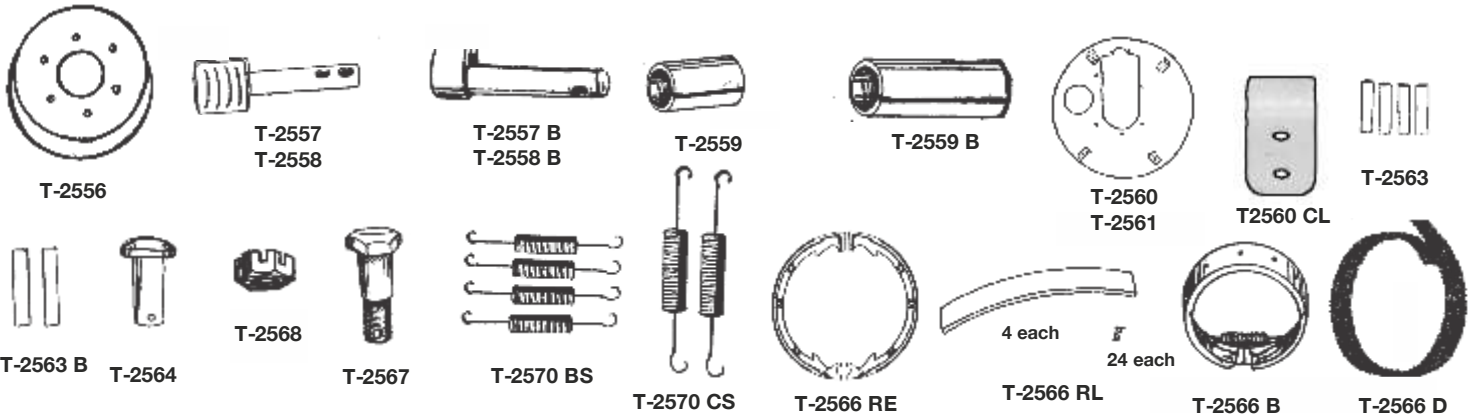

NUMBER	NAME OF PART	PRICE	NUMBER	NAME OF PART	PRICE
T-2556	1909-25 USA manufactured quality rear brake drum	34.95	T-2563	1909-25 Camshaft lever pins (4)	.60 set
T-2557	1909-25 Emergency brake camshaft Right hand	10.50	T-2563 B	1926-27 Camshaft lever pins	.60 pr.
T-2557 B	1926-27 Emergency brake camshaft Right hand	17.00	T-2564 STD	1909-27 Brake rod clevis pins Std (4)	.70 set
T-2558	1909-25 Emergency brake camshaft Left hand	10.50	T-2564 OV	1909-27 Brake rod clevis pins Over-size (4)	.70 set
T-2558 B	1926-27 Emergency brake camshaft Left hand	17.00	T-2566	1909-25 Cast iron emergency brake shoes	Disc.
T-2559	1909-25 Brake camshaft bushing (2 required)	1.20 ea.	T-2566 RL	Lining only for T-2566 RE	31.00
T-2559 B	1926-27 Brake camshaft bushing brass (2 req)	3.50 ea.	T-2566 B	1926-27 Emergency Brake Band w/o lining, may require fitting at cam area	38.00 ea.
X-2559	1909-27 Brake camshaft bushing driver	14.50	T-2566 RE	1909-25 Lined brake shoe 4 pc. set	79.95
T-2560	1926-27 Right hand brake backing plate, USA Mfg.	36.50	T-2566 D	1926-27 Emergency brake lining	44.00
T-2560 CL	1926-27 Backing plate clip. Holds brake band in place.	5.75	T-2567	1909-27 Brake shoe pivot bolt	2.50
T-2561	1926-27 Left hand brake backing plate, USA Mfg.	36.50	T-2568	1909-25 Brake shoe pivot bolt nut	.70
T2562 A	1909-25 New Emergency brake cam lever	20.00	T-2570 BS	1909-25 Brake shoe spring set (4)	3.75
T-2562 B	1926-27 Emergency brake cam lever	12.00	T-2570 CS	1926 Brake shoe spring set (2)	3.00
T-2562 U	1909-25 Emergency Brake cam lever - Used	12.00	T-2818 B	1926-27 Wood wheel brake drum. USA manufactured to original specifications.	65.00
			T-2889	1926-27 Wire wheel brake drum. USA manufactured to original specifications.	65.00

Rocky Mountain Brakes

NUMBER	NAME OF PART	PRICE
T-2565 A	1909-25 Rocky Mountain external brake system. A must for cars equipped with high speed ring gears, ruckstell axles or overdrives. Comes with instructions and everything needed to install. Inc. brake rods	815.00
T-2565 B	1926-27 Rocky Mountain external brakes system for large drum rear end. Uses existing drums. Complete w/instructions. Inc. brake rods	695.00
T-2565 S	1909-27 "EZ" Adjust Slider. Used with Rocky Mountain Brakes to prevent brake light from coming on when applying emergency brakes.	38.75
T-2565 TT	1919-27 Rocky Mountain external brake system for TT trucks.	730.00

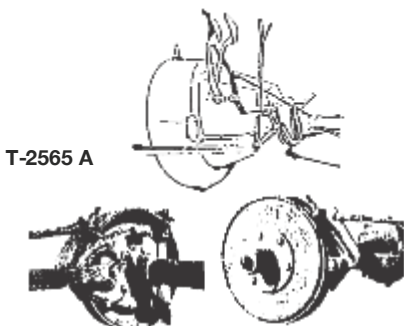

Rocky Mountain Brake Pedal

(Complete w/extension on bottom and new shaft)

NUMBER	NAME OF PART	PRICE
T-2565 PED1	1909-14 brake pedal	123.00
T-2565 PED2	1915-16 brake pedal	123.00
T-2565 PED3	1917-25 brake pedal	123.00
T-2565 PED4	1926-27 brake pedal	123.00

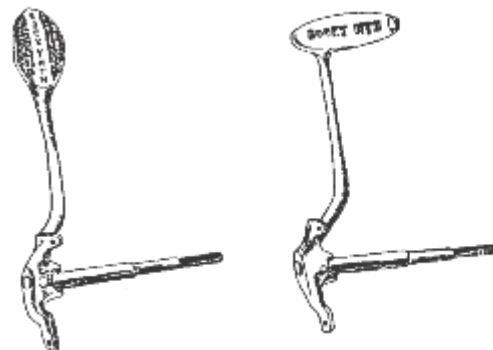

T-2565 PED3

T-2565 PED4

Front Axle, Radius Rod and Wheels

* Official Licensed Product

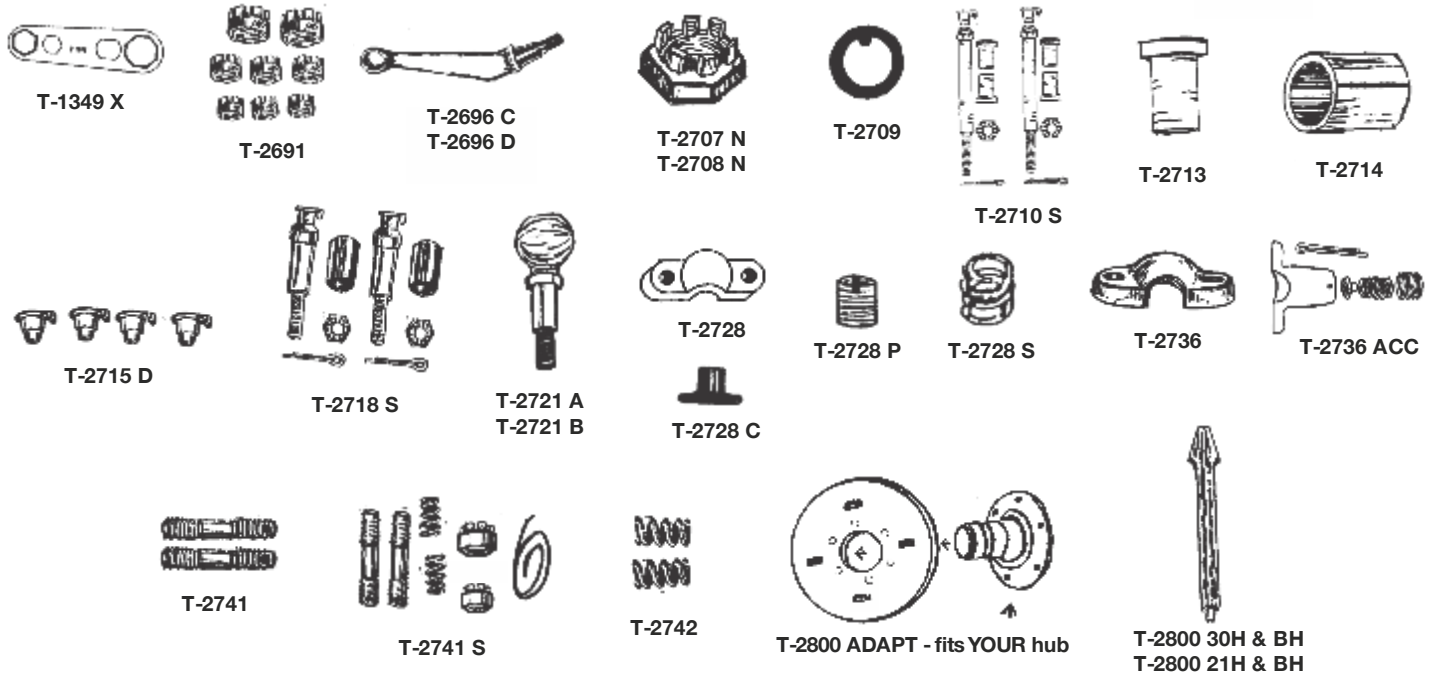

NUMBER	NAME OF PART	PRICE	NUMBER	NAME OF PART	PRICE
T-1349 X	Wrench that fits spindle nuts, hub caps, wheel bearing & spark plugs	5.20 ea.	T-2736	1909-27 Radius rod ball cap socket	10.75
T-2691	Steering and axle castellated cadmium nut set	4.50	T-2736 ACC	1909-27 Spring loaded radius rod ball support assy. Holds radius ball secure, helps prevent shimmy.	51.00
T-2696 C	1919-27 Spindle arm w/bushing, Right	11.95	T-2741	Radius cap bolts	1.00
T-2696 D	1919-27 Spindle arm w/bushing, Left	11.95	T-2741 S	1909-27 Radius cap mount stud and spring set	5.00
T-2707 N	1909-27 Spindle nut, left hand thread, passenger side	3.75	T-2742	Radius cap spring	.55
T-2708 N	1909-27 Spindle nut, right hand thread, driver's side	3.75	T-2800 ADAPT	Adapts your wooden Model T hubs to use Model A wheels or Model T wire wheels. No modifications required. High grade laser cut steel, grade 8 bolts. Easy installation. 1 set for all four wheels.	530.00 set
T-2709	Spindle Washer	2.00 pr.	T-2800 21BH	BH Wood spoke for 21" rim with 5/8" tenon	12.75
T-2710 S	1909-27 Spindle bolt and bushing set	48.00	T-2800 30BH	BH Wood spoke for 30 x 30-1/2" rim with 5/8" tenon	12.75
T-2713	1909-27 Spindle bolt bushings	4.00 ea.	T-2800 21 H	Wood Spokes for 21" wheel, need 12, 1/2" tenon	12.75 ea.
T-2714	1909-27 Spindle arm bushing	.95	T-2800 30 H	Wood Spokes, 30 x 31 1/2, 1/2" tenon	12.75
T-2715 D	1915-27 Lift up spindle oiler set (4)	4.50	T-2801 H	1912-17 Wood Fellow Wheel Plates - Hayes	4.25
T-2718 AS	1909-16 Tie rod bolt set hardened and ground with original style oilers	39.75	T-2801 P	1912-17 Wood Fellow Wheel Plates - Prudden	4.25
T-2718 BS	1917-27 Tie rod bolt set hardened and ground with original style oilers.	25.75	T-2804	1909-27 Demountable clincher rim with cadmium plating and lugs 30 x 3 1/2	255.00
T-2718 S	1909-27 Tie rod bolt and bushing set	Disc.			
T-2721 A	1911-18 Tie Rod Ball	12.95			
T-2721 B	1919-27 Tie Rod Ball	12.95			
T-2733 RK	Radius ball repair kit. Old worn ball must be cut off and this unit welded on	110.00			
T-2728	1909-27 Tie rod ball cap socket	10.25			
T-2728 ACC	Apco tire rod ball cap assembly spring loaded type	31.00			
T-2728 C	1909-27 Accessory ball socket seat	1.75			
T-2728 P	1909-27 Accessory ball socket plug	2.30			
T-2728 S	1909-27 Accessory ball socket spring	1.95			
T-2728 SH	Wishbone & Drag Link Shim Set	8.50			

Front Axle, Radius Rod and Wheels *(continued)*

* Official Licensed Product
Official Licensed Product

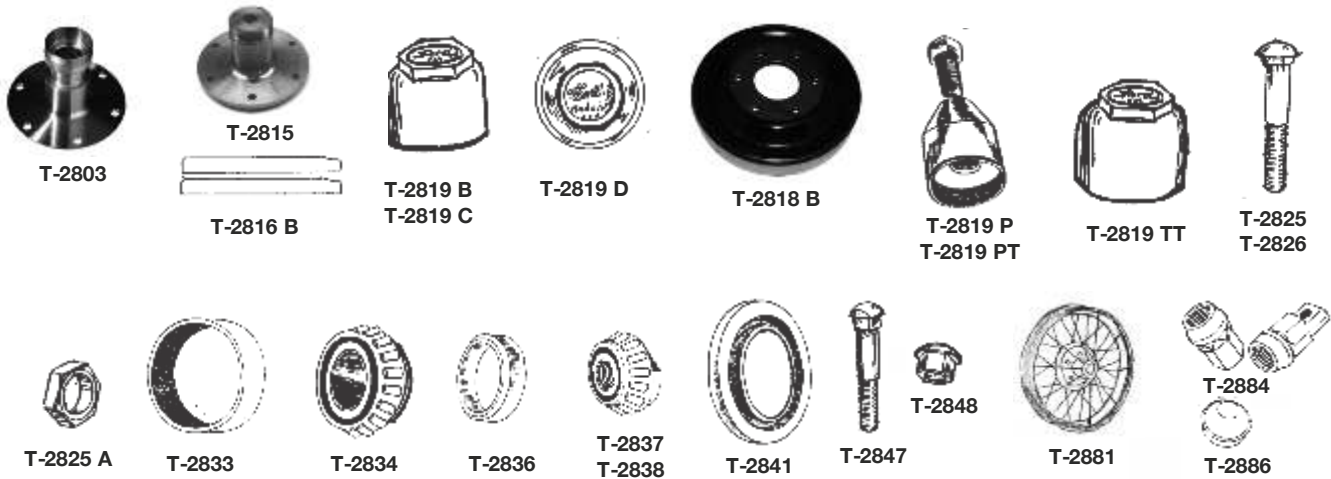

NUMBER	NAME OF PART	PRICE	NUMBER	NAME OF PART	PRICE
T-2802 A	1909-15 Oval head Felloe Rivet	.35 ea.	T-2826	1909-27 hub bolts for wood spoke wheels 2 1/8" to head rear	.75 ea.
T-2802 B	1909-15 Truss head Felloe Rivet	.35 ea.	T-2826 RM	1909-25 Extra length hub bolts for wood spoke wheels when using rocky mountain brakes 3/8" x 16" x 2.270" Set of 6.	15.00 set
T-2803	1916-27 Front hub for wood wheels. Will fit 1909-27	205.00	T-2833	1909-27 Inner front wheel bearing cup	19.25
T-2809	Felt Hub Washer	.70 ea.	T-2834	1909-27 Inner front wheel bearing	27.50
T-2815	1912-27 Rear wheel hub wood wheels.	135.00	T-2836	1909-27 Outer front wheel bearing cup	9.25
T-2815 TC	Hub thread chaser. Repairs damaged threads.	85.00	T-2837	1909-27 Right hand outer threaded bearing, Driver Side	84.00
T-2816 B	1912-27 Axle key (A-4243)	1.95 pr.	T-2838	1909-27 Left hand outer threaded bearing, Passenger Side	82.00
T-2818 B	1926-27 Brake drum for wooden wheels. Made to original specifications	65.00	T-2841	1919-27 Front wheel inner dust shield	5.50 ea.
*T-2819 B	1913-16 Hub caps - brass (pkg. of 4)	56.00	T-2845 E	1925-27 21" Split rim	255.00
*T-2819 C	1917-27 Hub caps - chrome (pkg. of 4) Wood spoke wheels	63.00	T-2847	Demountable rim bolt	1.25
*T-2819 D	1926-27 Hub caps - chrome over brass. Wire spoke wheels set of 5 needed.	14.25 ea.	T-2848	Demountable rim nut	1.45
T-2819 P	1909-27 Rear Wood Spoke wheel puller. Precision machined from high quality steel. If you don't need this to get your rear wheels off you are probably running them too loose and risking damage to the axle hub & keyway.	53.00	T-2847/48 S	1919-27 Demountable rim bolt and nut set. 4 bolts & 4 nuts for one wheel	9.00 set 4/33.00
T-2819 PT	Same as T-2819 P only for TT trucks.	82.00	T-2849 D	1919-25 Spare rim carrier clamp	9.00 ea.
T-2819 N	1917-27 Hub caps - Nickel (pkg. of 4) Wood spoke Wheels	63.00 set	T-2881	1926-27 Wire Wheels. Excellent quality. Primer coated.	330.00 ea.
*T-2819 TT	1919-27 Hub caps - chrome (rear) Model T Ton Truck	14.95	T-2883	1926-27 Front wire wheel hub bolts. Requires swedging to replace.	2.75
T-2825	1909-27 hub bolts for wood spoke wheels 2" to head front	.75 ea.	T-2884	1926-27 Wire wheel lug nuts, 23 pc.	60.00 set
T-2825 A	Thin hub bolt nuts (set of 6)	.75 set	T-2884 SS	1926-28 Stainless steel wire wheel lug nuts	110.00 set
			T-2886	1926-27 Wire Wheel Dust Caps	10.00 ea.
			T-2888	1926-27 Rear wire wheel hub bolts. Requires swedging to replace.	2.75
			T-2889	1926-27 Brake drum for wire wheel	65.00

Gas Tank

* Official Licensed Product
Official Licensed Product

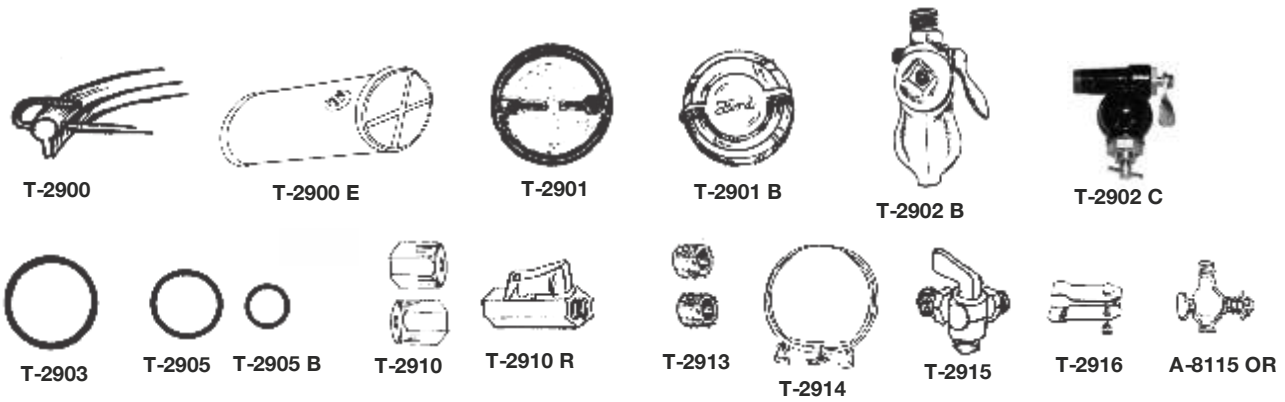

NUMBER	NAME OF PART	PRICE	NUMBER	NAME OF PART	PRICE
T-2900	1926-27 Fuel vent gasket	2.50	T-2910	1909-27 Gas line pack nut set (2)	3.35
T-2900 B	1911-12 Gas Tank	215.00	T-2910 R	Model T gasoline valve. Modern gasoline ballcock valve.	13.95
T-2900 C	1912-13 Center Outlet Gas Tank	185.00	T-2913	1909-27 Gas line seal (packing) (2)	.80
T-2900 D	1913-20 Round Gas Tank	150.00	T-2913 NEO	Gas line packing (Neoprene)	.90 ea.
T-2900 E	1920-25 Oval Gas Tank	150.00	T-2914	1913-20 Round gas tank mounting brackets	22.50
T-2900 F	1916-25 Sedan gas tank.	165.00	T-2914 B	1920-25 Oval gas tank mounting brackets	27.50
T-2900 S	1909-27 Speedster Tank	230.00	T-2915	1909-27 Fuel line shut off valve. Replaces the carburetor elbow & eliminates cutting the gas off at the sediment bowl. All brass USA mfg.	21.00
T-2901	1909-25 Early gas cap	6.95	T-2916	1921-27 Gas line clamp	3.25
*T-2901 B	1926-27 Gas cap	17.75	T-2917	1926-27 Webbing that fits on top of gas tank and two cowl supports.	5.00
T-2902 B	1911-25 Gas sediment bowl assembly w/o petcock. USA made from brass for earlier cars but can be painted for later.	60.00	T-2919	1926-27 Ribbed lower tank pads. Fits between gas tank and straps.	11.00
T-2902 C	1926-27 Sediment bowl for cowl gas tanks. US made cast brass unit.	60.00	T-2921	1926-27 Overflow Pipe set for Cowl Tanks	33.50
T-2902 SC	1909-27 Sediment Bowl Screen	.95	A-8115 OR	1909-31 Petcock, Sediment Bulb & Crankcase	8.95
T-2903	1926-27 Gas Cap gasket	.35	A-9155 RK	1926-31 Sediment Bowl Repair Kit (26-27 uses screen & lead gasket only)	3.95
T-2905	1909-25 Sediment Bowl Lead Flange Gasket	1.25			
T-2905 B	1926-27 Sediment Bowl Lead Flange Gasket	1.60			
T-2909	1909-25 Steel gas line. You bend to shape. No fittings	4.00			
T-2909 F	1926-27 Steel gas line without fittings for open cars.	3.10			

Engine Head and Gaskets

* Official Licensed Product
Official Licensed Product

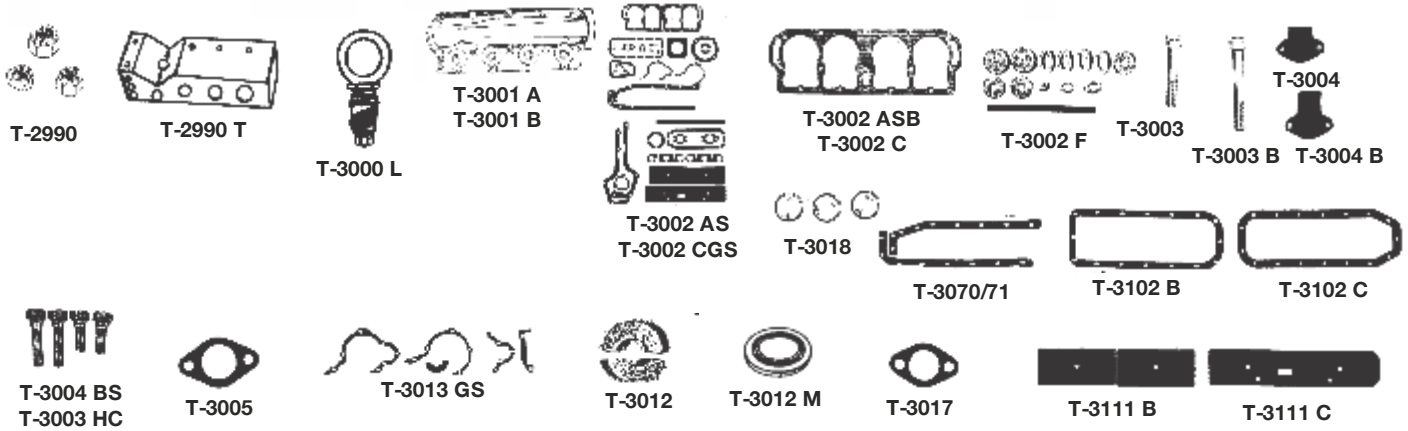

NUMBER	NAME OF PART	PRICE	NUMBER	NAME OF PART	PRICE
T-2990	Castellated nut set for motor (36 pc.)	15.00 set	T-3004	1909-16 Water outlet	23.50
T-2990 T	Tool that makes drilling cotter pin holes a snap	36.00	T-3004 B	1917-25 Water outlet	25.00
T-3000 L	Model T engine lift ring	8.95	T-3004 BS	1909-27 Water outlet bolts (4 pc.)	1.25
T-3001 A	A High Compression Aluminum Model T head 6 to 1 compression. Original appearance	375.00	T-3004 E	1926-27 Cylinder head water outlet with fan bracket	103.00
T-3001 B	Same as above, except early low head design.	405.00	T-3005	1909-27 Water outlet gasket	.35
T-3002 AS	1909-27 Engine gasket set, asbestos head gasket	40.00	T-3009 T	Timer cover alignment tool	13.50 ea.
T-3002 ASB	Asbestos Head Gasket	16.50	T-3012	1909-27 Front oil seal (felt crankshaft seal)	1.15
T-3002 C	Copper Head Gasket	29.00	T-3012 M	1909-27 Modern day camshaft seal	4.95
T-3002 CGS	1909-27 Engine gasket set, copper head gasket	46.00	T-3012 SL	Crankshaft Repair Sleeve	42.95
T-3002 F	Felt - All the felt seals needed in the Model T	5.50	T-3013 GS	1909-27 Timing cover gasket set	3.75
T-3002 M	1909-27 Premium head gasket with steel core and high density gasket material, with silicone material around water passage	25.95 ea.	T-3017	1909-27 Water Inlet Gasket	.35
T-3003	1909-17 Grade 8 Low head bolts (15 pc.)	13.00	T-3017 C	1915-27 Timing gear side cover gasket	.75
T-3003 B	1918-27 Grade 8 High head bolts (15 pc.)	13.00	T-3018	1914-27 Engine freeze plugs (set of 3)	1.30
T-3003 C	1926-27 Grade 8 Nickel plated high head dome shaped bolts. (15 pc. Set)	17.50 set	T-3018 BR	1914-27 Freeze plugs, brass	3.00 set
T-3003 HC	Head bolt & washer set for high compression aluminum head	Disc.	T-3070/71	1909-27 Crankcase to Cyl. Gasket	2.50
T-3003 W	1909-27 SS Head Stud Washers (15 pc.)	2.25	T-3102 B	1911-21 Pan gasket	3.50
			T-3102 C	1924-27 Pan gasket	3.50
			T-3111 B	1912-24 Valve cover gasket	2.50 pr.
			T-3111 C	1921-27 Valve cover gasket	2.50 ea.

Pistons and Connecting Rods

* Original Equipment Products
From the Motor to the Garage

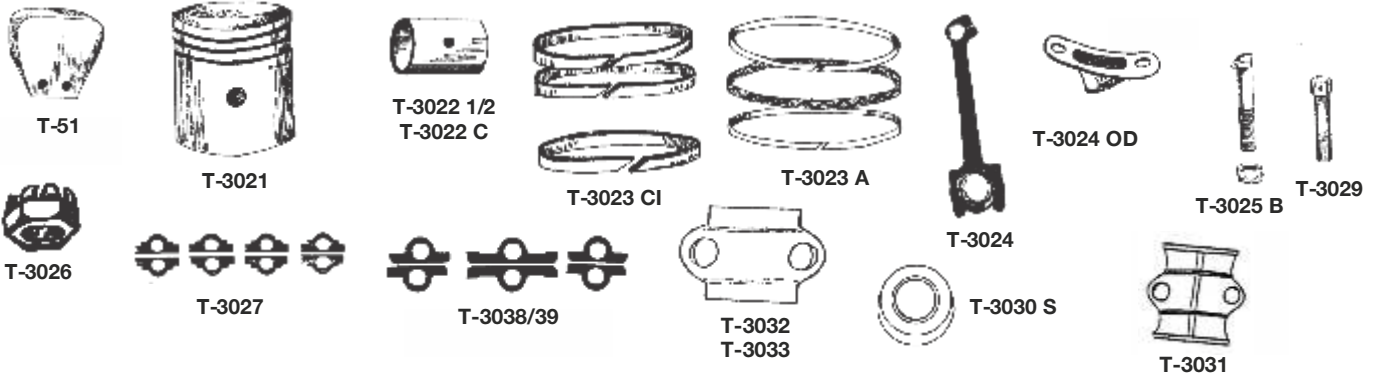

NUMBER	NAME OF PART	PRICE	NUMBER	NAME OF PART	PRICE
T-51	1909-27 Crankshaft counterweights for a smoother running engine. Ductile steel.	95.00	T-3024 STD	1909-27 Engine rods with x groove (exchange only)	275.00 set
T-3021 STD	1909-27 Aluminum pistons	80.00	T-3024 .010	1909-27 Engine rods with X groove (exchange only)	275.00 set
T-3021 .020	1909-27 Aluminum pistons	80.00	T-3024 .020	1909-27 Engine rods with X groove (exchange only)	275.00 set
T-3021 .030	1909-27 Aluminum pistons	80.00	T-3024 .030	1909-27 Engine rods with X groove (exchange only)	275.00 set
T-3021 .040	1909-27 Aluminum pistons	80.00	T-3024 .040	1909-27 Engine rods with X groove (exchange only)	275.00 set
T-3021 .060	1909-27 Aluminum pistons	80.00	T-3024 OD	Model T connecting rod oil dips, set of 4	12.95
T-3021 .080	1909-27 Aluminum pistons	80.00	T-3025 B	Engine Rod Bolts & nuts, used original	Disc.
T-3022 1/2	Piston pin bushing for cast iron pistons, 1909-23 (.934)	14.95 set	T-3025 OR	Engine Rod Bolt, original style	6.25
T-3022 C	Piston Pin Bushings for Cast Iron Pistons, 1923-27 (.872)	21.00 set	T-3026	Engine Rod Nut, original style	1.00
T-3023 CI STD	1909-27 Rings for cast iron pistons	53.00	T-3027	1909-27 Model T rod shims	6.75
T-3023 CI .020	1909-27 Rings for cast iron pistons	53.00	T-3029	Connecting rod pin lock bolt	2.50
T-3023 CI .030	1909-27 Rings for cast iron pistons	53.00	T-3031	Rear main bearing cap 3 5/32" bored Std. w/.015 shim. Exchange Only	58.50
T-3023 CI .040	1909-27 Rings for cast iron pistons	53.00	T-3032	Front main bearing cap 1 15/16" bored Std. w/.015 shim. Exchange only.	49.50
T-3023 CI .060	1909-27 Rings for cast iron pistons	53.00	T-3033	Center main bearing cap 2 1/32" bored Std. w/.015 shim. Exchange only.	49.50
T-3023 A STD	1909-27 Rings for aluminum pistons Hastings	66.00	T-3038/39	1909-27 Model T main bearing shims	6.95
T-3023 A .020	1909-27 Rings for aluminum pistons Hastings	66.00			
T-3023 A .030	1909-27 Rings for aluminum pistons Hastings	66.00			
T-3023 A .040	1909-27 Rings for aluminum pistons Hastings	66.00			
T-3023 A .060	1909-27 Rings for aluminum pistons Hastings	66.00			
T-3023 A .080	1909-27 Rings for aluminum pistons Hastings	66.00			

Crankshaft, Camshaft, Valves, Exhaust Manifold

* Official Licensed Product
Wendell Motors & Equipment

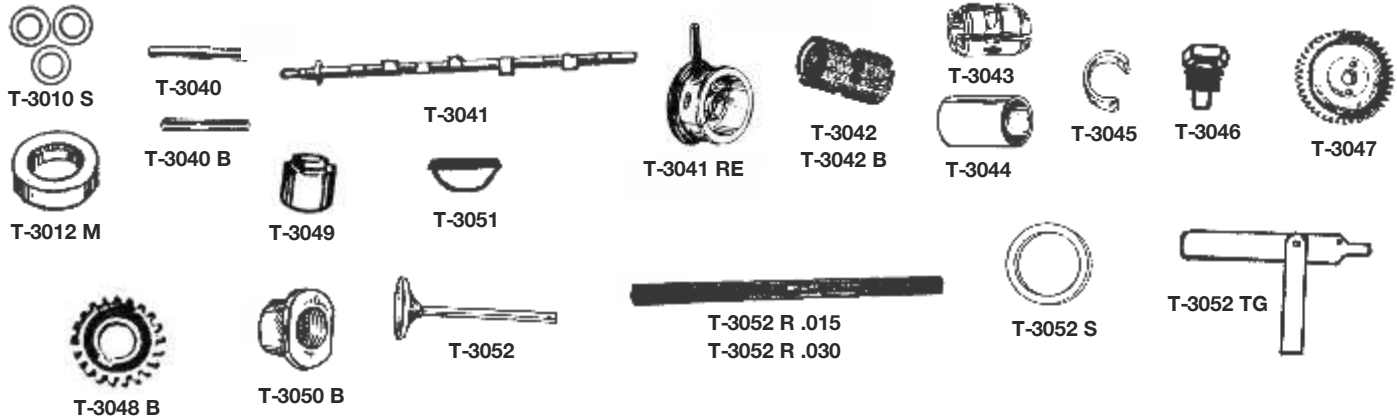

NUMBER	NAME OF PART	PRICE	NUMBER	NAME OF PART	PRICE
T-3010 S	Camshaft shim set (Shims rotor away from nut) Sometimes needed with Anderson timers	3.50	T-3045	1909-27 Camshaft bearing ring	1.40
T-3012 M	1909-27 Camshaft Seal, Modern type	4.95	T-3046	1909-27 Camshaft bearing set screw	3.25
T-3012 SL	1909-27 Crankshaft Repair Sleeve	42.95	T-3047 AL	1909-27 Machined aluminum shaft gear	55.00
T-3030 S	1909-27 Crankshaft seal, modern type (Requires motor to be lifted off the pan)	5.50	T-3047 HP	1909-27 Nylon 6/6 camshaft gear with 7 1/2 degree advance for added horse power	65.00 ea.
T-3030 STD	1909-27 New crankshafts are cast in spheroidal graphite iron. Balanced & heat treated. Ground to .248 (std.)	Disc.	T-3047 PL	1909-27 Nylon 6/6 camshaft gear	63.00 ea.
T-3040	1909-19 Crankshaft starting pin	.75	T-3047 STD	1909-27 Camshaft fibre gear	Disc.
T-3040 B	1920-27 Crankshaft starting pin	.80	T-3047 .003	1909-27 Camshaft fibre gear	55.00
T-3041	1909-27 Model T camshaft, Standard regrind, Exchange only.	90.00	T-3047 .005	1909-27 Camshaft fibre gear	55.00
T-3041 B	1924-27 Standard regrind camshaft, Exchange only.	90.00	T-3048 B	1909-27 Steel crankshaft gear	14.50
T-3041 H	1909-24 Touring grind camshaft, Exchange only.	135.00	T-3049	1909-27 Camshaft dowel pin (2)	2.50 pr.
T-3041 BH	1924-27 Touring grind camshaft, Exchange only	135.00	T-3050 B	Camshaft Gear Lock Nut	4.00
T-3041 RE	1909-27 Aluminum replacement crankshaft pulley and pin. Has set screw to tighten down on worn shaft. 3 3/4" Diameter	59.95	T-3051	1909-27 Crankshaft gear key	.45 ea.
T-3041 RE2	1909-19 Aluminum 2 3/4" crankshaft pulley for early pans.	46.95	T-3052 AS	1909-27 Std. Stainless Valves .312	8.00 ea.
T-3041 280	1909-27 New Cam 280 grind for good performance. No core needed.	385.00	T-3052 BS	1909-27 .015 Stainless Valves	8.00 ea.
**T-3042	1909-24 Front cam bearing 1 31/32" long	60.00	T-3052 CS	1909-27 .030 Stainless Valves	8.00 ea.
**T-3042 B	1924-27 Front cam bearing, 1 25/32" long	60.00	T-3052 K	Modern valve spring keeper	2.75 ea.
**T-3043	1909-27 Center cam bearing	60.00	T-3052 L	Modern valve spring locks 2-pc	.40 pr.
T-3044	1909-27 Rear cam bearing	5.25	T-3052 M	Modern style valve, .030 OV stainless steel	7.00 ea.
			T-3052 R .015	Oversize valve stem reamer .015	47.95
			T-3052 R .030	Oversize valve stem reamer .030	47.95
			T-3052 S	Valve seats	2.50
			T-3052-TG	1909-27 Valve timing tool. Set your valves for piston travel.	16.75

**Cam bearings are .003 oversize to compensate for wear on camshaft.

Crankshaft, Camshaft, Valves, Exhaust Manifold *(Continued)*

* Official Licensed Product
Steelcraft of Birmingham

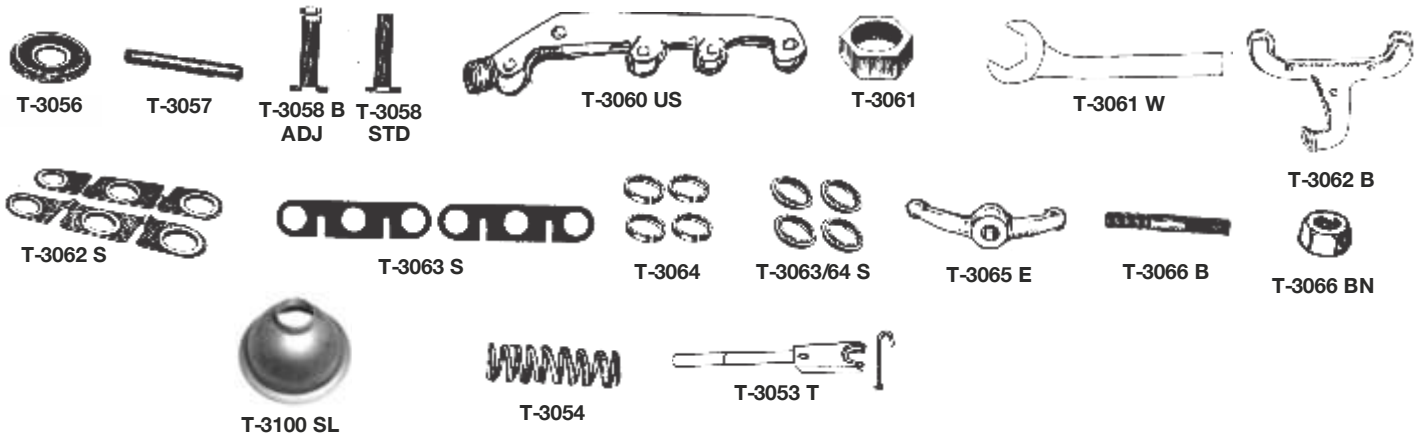

NUMBER	NAME OF PART	PRICE	NUMBER	NAME OF PART	PRICE
T-3053 T	1909-27 Valve Spring tool, hooks over manifold stud, makes spring removal easy.	25.00	T-3061	1909-27 Exhaust manifold pack nut	10.50
T-3054	1909-27 Valve springs, set of 8	4.95 set	T-3061 L	1909-27 Exhaust nut lock. Fits around pipe and keeps exhaust nut from backing off	5.50
T-3056	1909-27 Valve spring retainers	.70 ea.	T-3061 W	Exhaust Pack Nut Wrench	31.00
T-3057	1909-27 Valve pins, set of 8	1.60 set	T-3062 B	1912-15 Aluminum intake manifold	99.00 ea.
T-3058 STD	1909-27 Solid valve tappet	57.00 set	T-3062 S	1909-27 3 and 1 Inlet Exhaust Gasket w/gland rings made in gasket	14.25
T-3058 B	1909-27 Solid valve tappet 1/64" oversize	57.00 set	T-3062 U	1909-27 Used intake manifold	20.00
T-3058 ADJ	1909-27 Std. Adjustable valve tappets, set of 8	59.00 set	T3062 UV	1926-27 Used intake manifold vaporizer	24.00
T-3058 B ADJ	1909-27 Oversize adjustable valve tappets .015, Set of 8	59.00 set	T-3063 S	1909-27 Intake exhaust manifold gasket, asbestos. 2 pc. set	2.75 set
T-3058 CB	1909-27 Std, single lock valve tappet. Adjustable with 2 wrenches	73.00 set	T-3063/64 S	1909-27 Intake/exhaust manifold gasket and ring set. 6 pc. set	8.00 set
T-3058 DB	1909-27 .015 Oversize single lock tappets. Adjustable with 2 wrenches	73.00 set	T-3064	Metal Gland Rings	3.75 set
T-3058 DR	Value Tappet Reamer .015 oversize	60.00 ea.	T-3065 E	1909-27 Manifold Clamp	6.00
T-3058 E ADJ	.030 Oversize adjustable tappets	59.00 set	T-3066 B	1909-27 Manifold studs	1.60 ea.
T-3058 EB	1909-27 .030 Oversize single lock tappets. Adjustable with 2 wrenches	73.00 set	T-3066 BN	Manifold nut 3/8 x 24	.20 ea.
T-3058 ER	Value Tappet Reamer .030 oversize	60.00 ea.	T-3100 S	1909-14 Oil pan sump. Bottom of pan that drain plug is in. Made from thick machined steel. Quality USA mfg.	34.00
T-3060 ADP	1909-27 Adapter plate allows you to use a Model A manifold on your T.	69.95	T-3100 SL	1909-14 Oil pan sump. Thin spun metal like original	15.00
T-3060 D	Dual exhaust manifold. Requires exhaust work. Special flange for two pipe hook up. Increases power & performance.	295.00	T-3101	Crankcase lower cover bolts.	1.95
T-3060 MC	Stainless Steel Model T Manifold Cooker	60.00			
T-3060 US	1909-27 Exhaust Manifold (USA)	88.95			

Oil Caps, Distributor and Timer

* Official Licensed Products
Ward, Lee & Thompson, Inc.

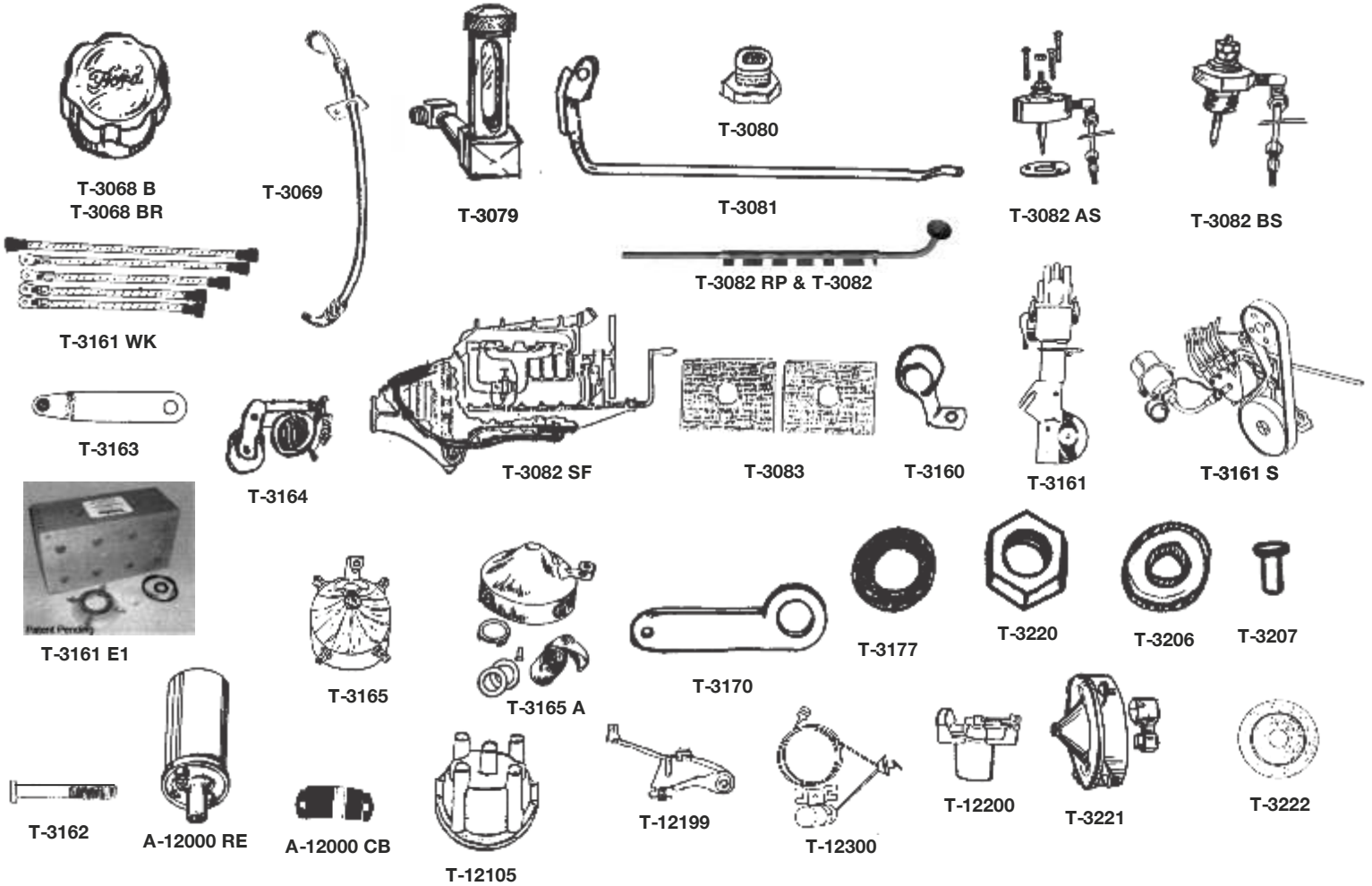

NUMBER	NAME OF PART	PRICE	NUMBER	NAME OF PART	PRICE
*T-3068 BR	1909-15 Script brass oil cap	18.50	T-3161 S	1909-27 High performance distributor. Mounts in place of timer. Complete with wires, coil, special tools & instructions.	290.00
*T-3068 B	1916-27 Script steel oil cap	Disc.	T-3161 T	1919-27 Distributor similar to T-3161 but has SS shaft with sealed bearings. Uses one control rod.	315.00
T-3069	1909-27 Dipstick kit. Eliminates getting under the car to open petcock. Installs at lower petcock hole.	39.95	T-3161 WK	1912-27 Wire set for T-3161	22.50
T-3079	Oil sight gauge. Fits on lower drain plug. Constant oil level indicator, all brass.	14.95	T-3162	Commutator case bolt	1.10
T-3080	Oil drain plug	2.25	T-3163	1912-27 Timer spring	1.95
T-3080 R	Oil pan plug repair kit, allows you to repair a stripped pan on the car. Complete with instructions.	12.50	T-3164	1911-27 Timer Roller assembly for Tiger timer	18.00
T-3080 W	Weld in oil pan plug repair kit. Requires pan removal, machining & welding.	6.50	T-3165	1911-27 Tiger Timer with steel roller assembly	60.00
T-3081	Inside oil line w/large funnel	45.00	T-3165 A	1909-27 Anderson Style Timer (flapper type). Heat treated parts, long lasting.	65.00
T-3081 HVOL	High volume outside oil line kit	83.95	T-3165 US	1917-27 USA remanufactured steel timer. Precision made with roller assembly. Exchange only	50.00
T-3082 AS	1909-25 Outside oil line kit	26.95	T-3167	Rotor assembly for Anderson Timer	34.00 ea.
T-3082 BS	1926-27 Outside oil line kit	22.95	T-3170	1909-27 Timer gauge	1.50
T-3082 SF	1914-27 Sure Feed Oil System. Kit includes new transmission cover with the oil pickup made in the cover and oil entry bracket for pan. Easily installed outside oil line system that guarantees oil delivery to the front of the oil pan.	Disc.	T-3177	1912-27 Timer felt	.75
T-3082 RD	1909-27 Accessory inside oil line. Fits inside pan under pan bolt retainer brackets. For driver side.	19.95	T-3206	1909-27 Commutator brush cap	.80
T-3082 RP	Same as above. For passenger side.	19.95	T-3207	1912-27 Timer pin	.30
T-3083	Motor mount blocks	3.00 pr.	T-3220	1909-27 Commutator lock nut attaches roller assembly to cam	1.50
T-3083 MB	1909-27 Engine Support Bolt Kit	5.75	T-3221	1919-27 New Day Timer, with brush	Disc.
T-3160	1909-27 Distributor spark plug wire holders	11.00 pr.	T-3221 B	1919-27 New Day Timer brush	8.95
T-3161 EI	True-fire electronic ignition. Does not change original appearance or sound. Replaces old coils & trim roller. No points condenser, rotor cap, distributor cap to wear out. Multi spark, easier starts, more power & hidden from view. Easy to install	370.00	T-3222	1919-27 Timer Shield	1.95
			A-12000 RE	6 volt coil	13.95
			A-12000 CB	Coil mounting bracket	2.60
			T-12105	1909-27 Distributor body	7.95
			T-12199	1909-27 Distributor point set	6.95
			T-12200	Model T Distributor rotor	6.25
			T-12300	Model T Distributor condenser.	10.50

Transmission and Magneto

* Original Equipment Products
From Motor Workshops

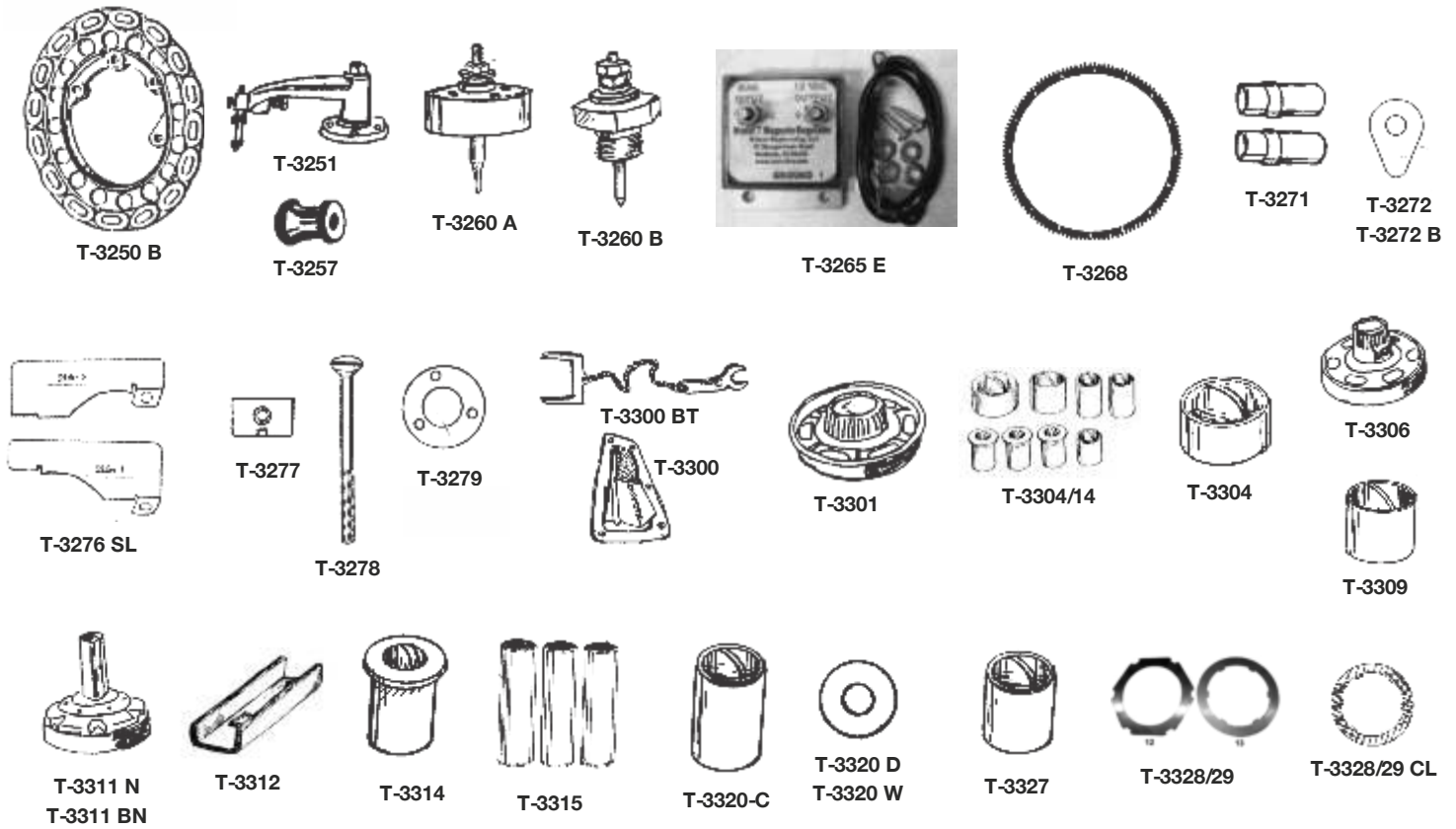

NUMBER	NAME OF PART	PRICE	NUMBER	NAME OF PART	PRICE
T-3250 A	Double stacked field coil must have your rebuildable core first. 6 week delivery time.	260.00	T-3304/14	1909-27 Complete 8-pc. set transmission bushings.	49.95
T-3250 B	Single stack magneto field coil, exchange only	225.00	T-3306	1909-27 New Reverse Drum w/ used gear (exchange only - installed on customer hub)	270.00
T-3250 MB	1909-27 Magneto field coil mounting bolts	5.25	T-3306 N	1909-27 USA mfg. New slow speed drum and gear, accurately machined. No exchange.	545.00
T-3251	Magneto Gap Gauge Tool	200.00	T-3306 X	Transmission Slow Speed Drum (Must be installed on your hub)	220.00
T-3257	1909-27 Aluminum magneto support spool	1.30 ea.	T-3309	1909-27 Slow speed bushing	7.95
T-3260 A	1909-25 Replacement magnet post	16.95	T-3311 N	1909-25 USA mfg. New brake drum and shaft accurately machined.	625.00
T-3260 B	1926-27 Replacement screw in magnet post	13.95	T-3311 BN	1926-27 USA new mfg. wide brake drum & shaft accurately machined	645.00
T-3265 E	Electronic Magneto voltage regulator.	99.95	T-3312	1926-27 Brake drum lug shoe	2.50
T-3268	1919-27 Flywheel ring gear	44.00	T-3313	1909-27 Triple Gear Set	240.00
T-3270	Flywheel to crankshaft bolt.	4.25	T-3314	Triple gear bushing	8.50
T-3271	Flywheel dowel pins	2.00	T-3315	Triple gear shafts (need 3)	8.50 ea.
T-3272	1909-27 Steel Magneto Coil shim	1.60 ea.	T-3317	1909-27 Transmission driven gear	67.50
T-3272 B	1909-27 Magneto coil shim, Laminated	1.25 ea.	T-3318	1909-27 Driven gear key.	.50
T-3276 SL	1909-27 Oil slingers used when not using magnets to sling oil for lubrication. Balanced with bolts & washers for slinger & flywheel ring gear. Set of 4.	39.95 set	T-3320 C	1909-27 Drive gear bushing	4.50
T-3277	1911-27 Magnet clamp plate	2.50	T-3320 D	1909-27 Transmission brake drum thrust washer Washers on inside of brake drum. 3 required	2.50 ea.
T-3278	1909-27 Magneto clamp screw. Need 16	.55 ea.	T-3320 W	1909-16 Transmission brake drum thrust washer. .025 thick used with T-3320 D	15.95
T-3279	Mag. Post Cork Gasket	.35	T-3323 B	1926-27 Driven plate bolt. Holds plate to drum (6/car)	6.50
*T-3300 BT	Band holding tool and wrench	15.00	T-3327	1909-27 Drive plate bushing	4.50
T-3300 M	1909-27 Transmission oil screen with magnet in screen to help pick up metal particles	28.50	T-3328/29	Transmission disc. set. Brand new heat treated catch discs (12 small and 13 large)	113.95 set
T-3301	1909-27 New transmission reverse drum w/used gear - exchange only (Installed on customer hub)	270.00	T-3328/29 CL	1909-27 Speed Clutch gives your car a neutral and a more positive engagement, 8 pc.	72.00 set
T-3301 N	1909-27 USA mfg. New reverse drum & shaft accurately machined. All new, no exchange.	560.00	T-3329	1909-27 Transmission clutch disc hex shape	4.00
T-3301 X	Transmission Reverse Drum (Must be installed on your hub)	220.00			
T-3304	1909-27 Drive gear bushing	9.50			

Transmission and Magnets *(continued)*

* Official Licensed Product
Official Model T Magazine

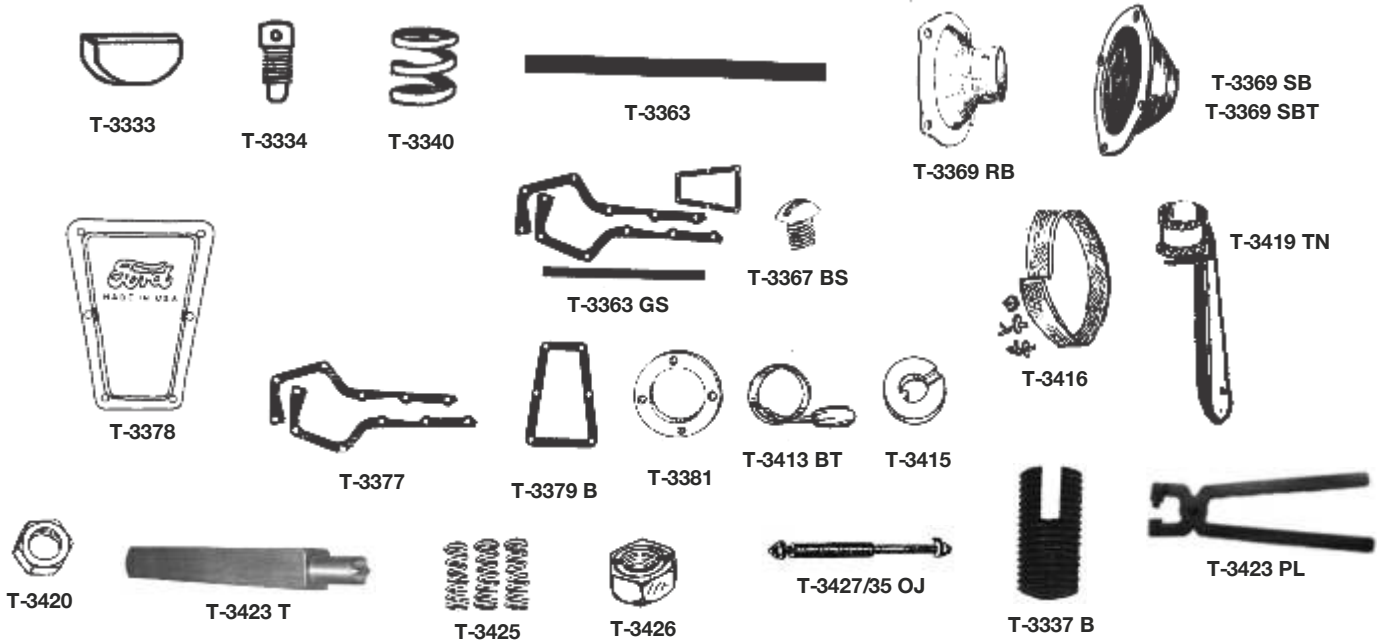

NUMBER	NAME OF PART	PRICE	NUMBER	NAME OF PART	PRICE
T-3331	1909-27 New Transmission Gear Shaft	195.00	T-3416	1909-25 Transmission lining, 3 narrow	58.00
T-3333	1909-27 Transmission clutch disc drum key.	1.75	T-3416 D	1926-27 Transmission lining, 2 narrow, 1 wide	70.00
T-3334	1909-27 Clutch disc drum set screw.	4.00	T-3416 D-KEV	Transmission Lining 1926-27 Made of woven Kevlar	99.00
T-3337	1909-25 Clutch finger	8.95	T-3416 KEV	Transmission Lining 1909-25 Made of woven Kevlar	89.00
T-3337 B	Transmission clutch finger screws	.50	T-3416 W	1909-25 Wood transmission lining	65.00
T-3340	1909-27 Clutch spring 110-115 lb at 2"	35.00	T-3416 BW	1926-27 Wood transmission lining	65.00
T-3363	1909-27 Front cover transmission seal	.95 ea.	T-3419 TN	1909-27 Band nut holding tool. Keeps dropped band nuts from falling into transmission.	Disc.
T-3363 GS	1912-27 Band changing gasket set - 4 pc.	4.50	T-3420	1909-27 Transmission adjusting screw nut.	.95
T-3367 BS	Transmission cover door bolts	1.00 set	T-3423 B	Brass transmission band lining rivets. Included in kits.	1.25
T-3368	Crankshaft alignment tool. Aligns transmission shaft with pan	32.50	T-3423 PL	1909-27 Band lining split rivet setting pliers (holds, splits, curls, and imbeds)	30.00
T-3369 RB	Rebabbed Model T Ball cap. Spun pored high speed babbit with circle groove for oil. Higher in price but worth the money as this supports the transmission. EXCHANGE	72.50 ea.	T-3423 T	1909-27 Band rivet tool that splits, curls and imbeds rivets. Saves time.	21.95
T-3369 SB	1909-27 ball bearing main cap can be installed w/engine in car. Uses high quality sealed bearing & eliminates oil leak & reduces vibration and crankshaft fatigue. Requires trimming 3/8" off drive shaft bell housing.	130.00	T-3425	1909-27 Transmission springs	1.60 set
T-3369 SBT	Same as T-3369 SB but requires transmission tailshaft be turned.	110.00	T-3426	1909-27 Transmission band nut	1.65 ea.
T-3377	1909-27 Transmission cover gasket	3.50 pr.	T-3427/35 OJ	Outside band adjusting shaft. Provides the means to adjust your bands from outside the transmission. No modifications made in transmission cover. Also has O-ring to stop pedal shaft leaks.	65.00 pr.
T-3378	1912-27 Transmission cover plate.	45.00			
T-3379 B	1909-27 Transmission cover door gasket	1.25			
T-3381	1919-27 Starter Drive Cover Gasket	.50			
T-3402 S	Model T Clutch Arm Shaft Seal (09-19 Cars Used 2 Seals 19-27 Cars Used 1 Seal) Requires Transmission Cover to be Machined	5.50 ea.			
T-3413 BT	1909-27 Band changing tool	8.50			
T-3415	1909-27 Transmission band washer	1.35 ea.			

Transmission and Magnets *(continued)*

* Official Licensed Product
World's Most Versatile

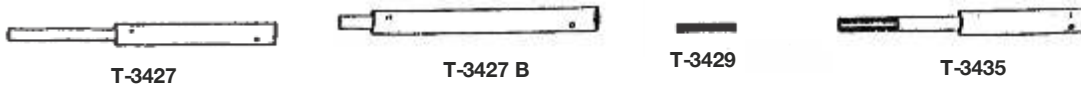

NUMBER	NAME OF PART	PRICE	NUMBER	NAME OF PART	PRICE
T-3427	1909-25 Slow speed shaft	9.00	T-3435 S	Pedal Shaft O-Ring Set - 3 Pcs (Fits between Housing & Pedal Shaft Cam)	.75
T-3427 B	1926-27 Slow speed shaft	9.00	T-3436	1909-27 Brake and reverse pedal support. Pedals come on this piece.	15.75
T-3427 BOS	1926-27 Slow speed shaft oversize .005	9.00	T-3437	1909-25 Reverse and brake pedal support bolt	1.50
T-3428	1909-27 Slow speed notch inside transmission. Mates to T-3442. Makes for smooth pedal operation	18.50	T-3437 C	1926-27 Reverse and brake pedal support bolt	2.45
T-3429	1909-25 Slow speed notch pin	.45	T-3437 N	1909-27 Nut for support bolts.	.60
T-3435	1909-27 Brake & reverse pedal shaft	11.50	T-3442	1909-27 Clutch pedal support mounts inside transmission cover. Mates with T-3428	15.75
T-3435 OS	1909-27 Brake & reverse pedal shaft oversize .005	11.50	T-3443	1909-27 Clutch pedal support bolt.	2.30
			T-3406 C	1913-27 Clutch release fork pin	.40

Pedal Pads and Handbrakes

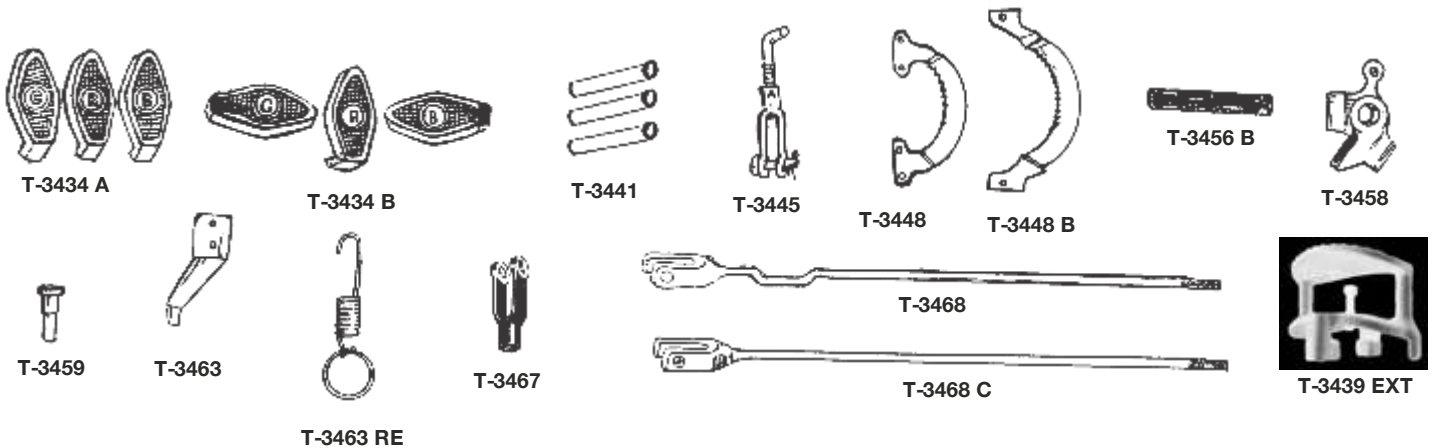

NUMBER	NAME OF PART	PRICE	NUMBER	NAME OF PART	PRICE
T-3434 A	1909-25 Pedal pads	8.75	T-3456 B	1909-27 Handbrake lever. Pin on cross-shaft	.45
T-3434 B	1926-27 Pedal pads	8.00	T-3458	1909-27 Handbrake pawl	5.95
T-3439 EXT	1909-25 Reverse pedal extension	35.00	T-3459	1909-27 Handbrake pawl rivet	.55
T-3439/40 EXT	1909-25 Brake & Clutch Pedal Extension	50.00 pr	T-3463	1909-27 Original type riveted spring for handbrake	1.75
T-3441	1909-27 Pedal to Shaft pins, (3)	.75 set	T-3463 RE	Handbrake spring replacement. Hooks around cross shaft and hooks to rod at pawl.	2.00
T-3445	1909-27 Slow speed connector	9.50	T-3467 OR	1909-27 Original Brake Rod Clevis	5.50
T-3445 L	1909-27 Slow speed connection link only	2.75	T-3467	1909-27 Brake Rod Clevis	2.80
T-3446	1909-27 Slow speed connection lock nut	.50	T-3468	1909-25 Brake rod (no clevis)	17.00 ea.
T-3448	1909-25 Handbrake quadrant	11.50	T-3468 C	1926-27 Brake rod (no clevis)	18.00 ea.
T-3448 H	1909-25 Hardened Handbrake quadrant	36.95	T-3468 M	1918-25 Brake rods, USA	55.00 pr.
T-3448 B	1926-27 Handbrake quadrant	11.50	T-3468 L	1926-27 Brake rods, USA	55.00 pr.
T-3448 BH	1926-27 Hardened Handbrake quadrant	36.95			
T-3448 RIV	Round head rivet 1/4" x 7/8" to attach handbrake quadrant to frame. Set of 5.	2.50 set			

Carburetor Control Rods

* Official Licensed Product
Speed Parts & Accessories

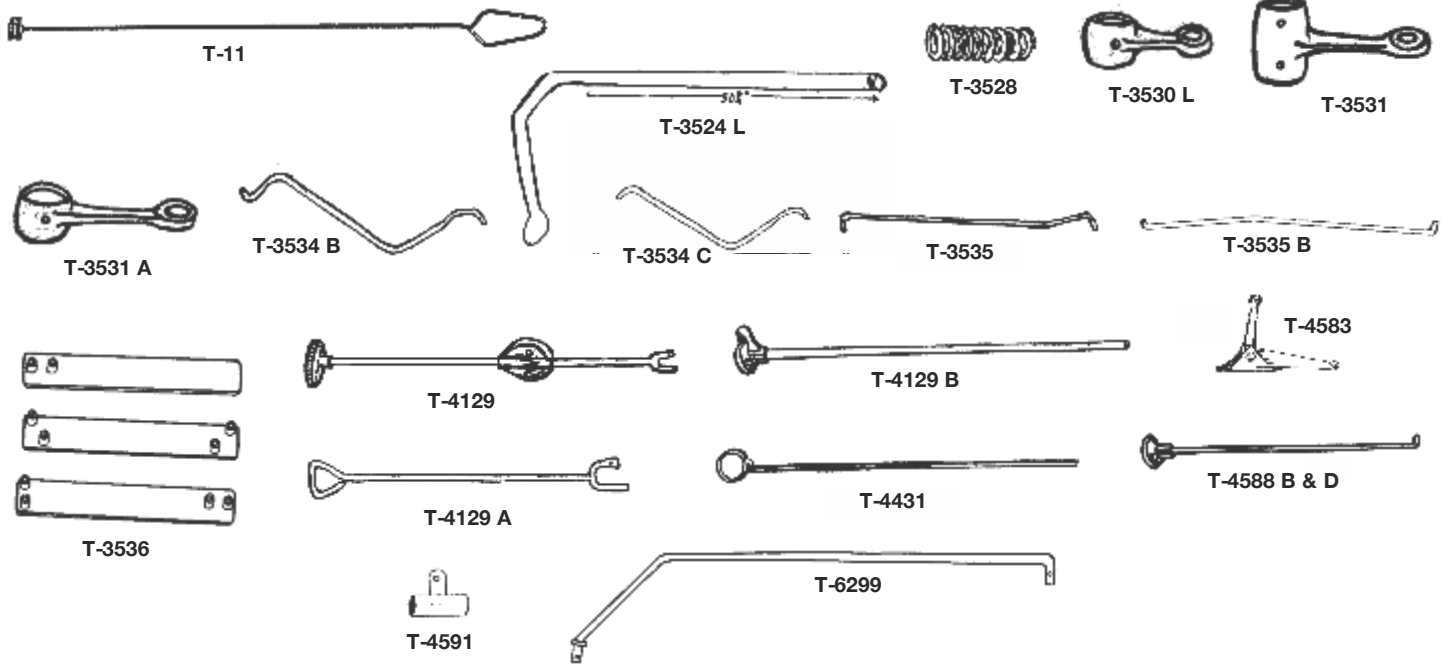

NUMBER	NAME OF PART	PRICE	NUMBER	NAME OF PART	PRICE
T-11	1909-27 Oil check rod	6.25	T-4129	1909-16 Carburetor control for brass cars	31.00
T-3524 L	1916-27 Spark & gas rods. USA mfg. 50" & 54" length. Chrome	Disc.	T-4129 A	1917-25 Carburetor adjusting rod	6.50
T-3528	Spark & throttle lever spring	.95 set	T-4129 B	1926-27 Choke Rod 32". Can be cut to shorter length if needed.	20.00
T-3529	1909-27 Pins for gas and spark levers (2)	.40	T-4431	1909-27 Choke Wire	2.75
T-3530 L	1909-27 Spark lever arm	9.00 ea.	T-4583	1919-25 Priming bell crank	5.25
T-3531	1909-14 Throttle lever arm	9.00 ea.	T-4587 B	1919-22 Sedan 17-11/16" Choke Rod	4.25 ea.
T-3531 A	1915-27 Throttle lever arm	9.00 ea.	T-4588 B	1919-22 Coupe/Rdst/Tour 13-9/16" Choke Rod	4.25 ea.
T-3534	1909-12 Commutator rod	Disc.	T-4588 D	1923-25 13-11/16" Choke Rod	4.25 ea.
T-3534 B	1912-25 Commutator control rod	4.00	T-4588 E	1923-25 17-1/8" Choke Rod	4.25 ea.
T-3534 C	1926-27 Commutator control rod	4.00	T-4588 F	1923-25 Tudor/4-Door 16-1/16" Choke Rod	4.25 ea.
T-3535	1909-25 Carburetor control rod	4.00	T-4591	1926-27 Choke rod sleeve	2.75
T-3535 B	1926-27 Carburetor control rod	5.75	T-6299	1927 Vaporizer control rod	Disc.
T-3535 E	1909-21 Carburetor control rod with angle joint	39.95	T-6300 A	1909-27 Accessory foot control. Makes Model T driving easier and is a must for cars with Ruckstell rear ends of auxiliary transmissions. Allows you to cruise w/hand throttle and accelerate w/foot.	89.95
T-3536	Carburetor & timer control rod bending tool	16.95 ea.	T-6300 B	1926-27 Accessory foot control (see above)	89.95

Engine Pans

NUMBER	NAME OF PART	PRICE	NUMBER	NAME OF PART	PRICE
T-3084/85 A	1909-11 Engine Pans (Early Open Valve Motors)	120.00 pr.	T-3084/85 D	1919-27 Engine Pans (All Model Ts with Starter)	120.00 pr.
T-3084/85 B	1911-14 Engine Pans (Later 1911 with closed Valve chamber & early 1914s)	120.00 pr.	T-3084/85 U	1919-27 Engine Pans (May Require Fitting)	80.00 pr.
T-3084/85 C	1914-18 Engine Pans (Later 1914s - 1918 Without Starter)	120.00 pr.			

Steering Wheels

* Original Licensed Product
Ward's Auto Supply

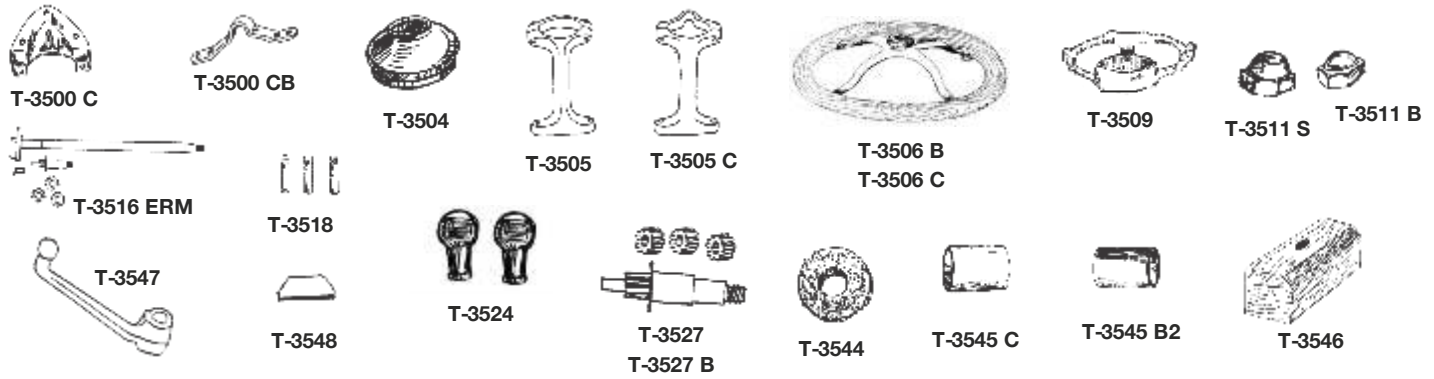

NUMBER	NAME OF PART	PRICE	NUMBER	NAME OF PART	PRICE
T-3500 C	1922-25 Steering to dash support bracket 2 pc.	54.95	T-3516 ERM	1921-27 5:1 steering kit. Includes new gears, pins and steering shaft. Adapts 5:1 steering to older cars for much safer operation.	275.00
T-3500 CB	1922-25 Steering to dash support bracket bottom half only	8.95	T-3518	1909-27 Steering gear pinion pins (3)	1.95 set
T-3500 SS	1909-27 Steering stabilizer	89.00	T-3520	Steering wheel keyway	1.00 ea.
T-3501 BL	1909-25 Steering Wheel Rim 16" - black	60.00	T-3523	Steering shaft nut	.75
T-3501 W1	1913-19 Steering Wheel Rim	130.00	T-3524	1909-27 Spark & Gas Knobs	24.50
T-3501 W2	1919-25 Steering Wheel Rim	130.00	T-3527	1909-25 Steering pinion gears 4/1 ratio	55.00 set
T-3501 W3	1926-27 Steering Wheel Rim	130.00	T-3527 B	1926-27 Steering pinion gears 5/1 ratio	55.00 set
T-3504	1909-14 Steering top cover, brass knurled & threaded	36.00	T-3540	1909-27 Steering Bracket Bolt (Long - Also Fits Crankcase to Frame)	1.50
T-3504 C	1915-27 Steering gear box cover, used-good-chrome/not perfect	20.00 ea.	T-3541	1909-27 Steering Bracket Bolt (Short - 2 Required)	2.00
T-3505	1915-27 Steering bracket without horn groove.	21.95 ea.	T-3544	Steering bracket felt washer	.50
T-3505 C	1919-27 Steering bracket with horn groove.	21.95 ea.	T-3545 C	1909-25 Steering bracket bushing	6.75
T-3506 B	Steering wheel with brass spider and wood rim	325.00	T-3545 B2	1926-27 Steering bracket bushing	5.75
T-3506 C	Steering wheel with chrome spider and wood rim	350.00	T-3546	1909-27 Hardwood block that fits between steering bracket and frame	2.95
T-3509	1909-15 steering gear quadrant	37.50	T-3547	Pitman Arm	34.95
T-3511 B	1909-14 Brass steering wheel nut, Lo Crown	5.25	T-3548	Pitman Arm Key	.65
T-3511 C	1916-27 Chrome steering wheel nut	5.25			
T-3511 S	1916-27 Steel steering wheel nut, Hi Crown	3.25			

Body Blocks, Floorboards and Pedal Plates

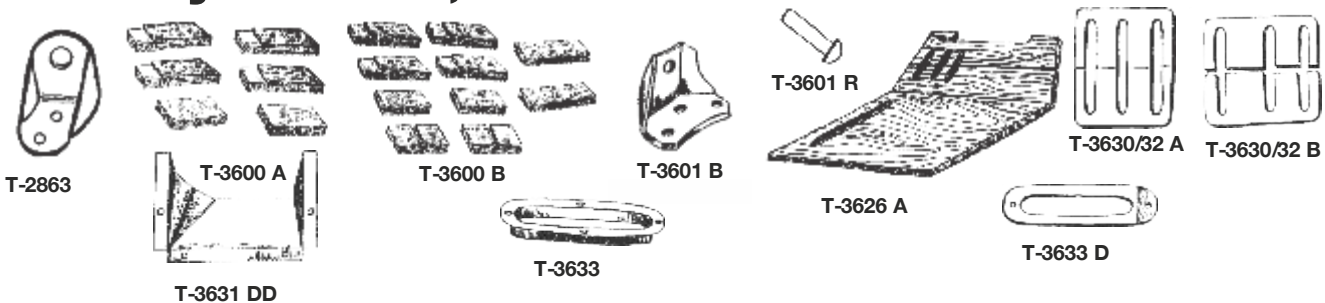

NUMBER	NAME OF PART	PRICE	NUMBER	NAME OF PART	PRICE
T-3600 A	1926-27 Touring and Tudor body to frame blocks	29.00	T-3626 C	1926-27 Floorboards, Coupe & Tudor	55.00
T-3600 B	1926-27 Coupe and Roadster body to frame blocks	35.50	T-3626 FH	1926-27 Touring & Roadster Front Floorboards - Hardwood	127.95
T-3600 C	1926-27 Tudor mounting blocks.	38.75	T-3631 DD	1909-25 Draft deflector. Keeps engine heat from entering car around foot pedals	6.50
T-2863	1909-27 Body on frame bracket	20.95 ea.	T-3630/32 A	1916-25 Replacement steel plates for the pedal area	16.00
T-3601 A	1909-16 Body to frame brackets, 6 per car	22.00	T-3630/32 B	1926-27 Replacement steel plates for the pedal area	16.00
T-3601 B	1917-25 Body brackets, 6 per car	22.00 ea.	T-3633	1916-25 Emergency brake metal floorboard trim, 8 3/4"	2.95
T-3601 R	1909-27 Body to frame bracket rivet set 8 pc.	3.25 set	T-3633 D	1926-27 Emergency brake metal floorboard trim	3.95
T-3626 A	1915-25 Floorboards, Open Car	63.50			
T-3626 B	1926-27 Floorboards, Open Car	63.50			
T-3626 BR	1926-27 Touring Rear Floorboards -Hardwood	63.50			

Cowl, License Plate & Tail Light Brackets

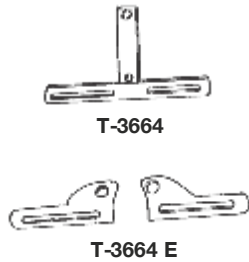
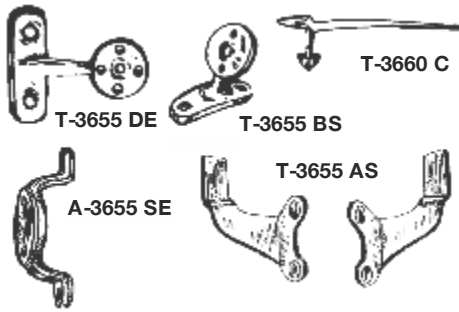

NUMBER	NAME OF PART	PRICE
T-3655 AS	1909-14 Side lamp brackets	35.00 pr.
T-3655 BS	1923-25 Kerosene side light brackets for open cars	35.00
T-3660 C	1915-19 Touring tail light bracket	35.00 ea.
T-3655 DE	Depot hack or truck sidelamp brackets	52.95 pr.
T-3655 SE	Closed car sidelamp brackets	49.50 pr.
T-3664	1922-27 One piece license plate bracket	4.25
T-3664 E	1909-21 Two piece license plate brackets	3.95

Springs

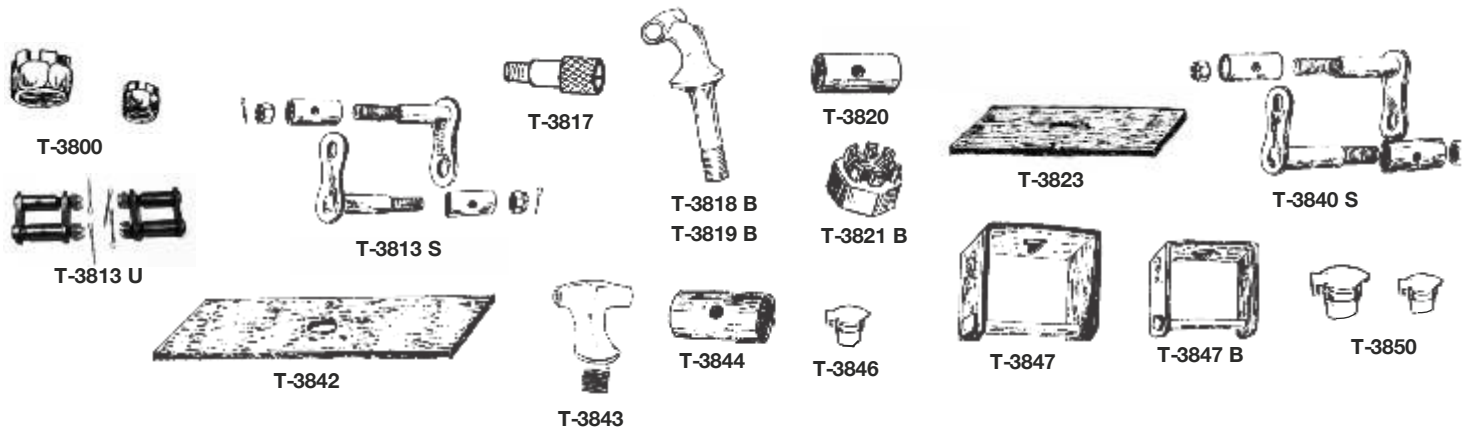

NUMBER	NAME OF PART	PRICE	NUMBER	NAME OF PART	PRICE
T-3800	1909-27 18 pc. castellated nut set for springs, shackles and clips	10.95	T-3823	1909-27 Front spring cushion pad	1.35
T-3801	1909-18 Front tapered leaf spring	210.00	T-3824 A8	1909-25 Rear clipped leaf spring	410.00
T-3801 A7	1919-25 Front clipped leaf spring Hi-arch	210.00	T-3824 A9	1926-27 Rear clipped leaf spring	430.00
T-3801 A8	1926-27 Front clipped leaf spring Lo-arch	205.00	T-3840	1919-27 Rear spring shackle set. Forged USA mfg.	95.00 set
T-3813 B	1919-27 Front spring shackle set. Forged USA mfg.	95.00 set	T-3840 GF	1909-27 Replacement rear spring shackles with grease fittings L-type.	47.00 set
T-3813 GF	1909-27 Replacement front spring shackles with grease fittings for easy lubrication.	45.00 set	T-3840 S	1909-27 Replacement L. Type Spring shackles, complete set for rear spring	33.50 set
T-3813 S	1909-27 Replacement type spring shackles. Complete set for front spring. L Type.	32.00	T-3840 U	1909-27 Replacement rear spring shackles. U-Type	28.00
T-3813 U	1909-27 Replacement front spring shackles. U-Type	28.00	T-3842	1909-27 Rear spring cushion pad	1.65
T-3817	1909-15 Brass twist type oiler	9.00	T-3843	1909-25 Rear spring perch	40.00 ea.
T-3818 B	Front spring perch, right hand	43.50	T-3844	1909-27 Rear spring or perch bushing	.75
T-3819 B	Front spring perch, left hand	43.50	T-3846	1916-27 Spring & perch oiler, 8 pc. set	7.00
T-3820	1909-27 Front spring or perch bushing	.55	T-3847	1918-27 Script rear spring clip	6.00 pr.
T-3821	1909-19 Front spring perch nut	3.00 pr.	T-3847 B	1916-27 Script front spring clip	3.95 pr.
T-3821 B	1919-27 Front perch nut	7.50 pr.	T-3850	1916-27 Original type oilers. Lift up type for springs, perch and rear brake shaft, 12 pc. set	11.50 set

Crank

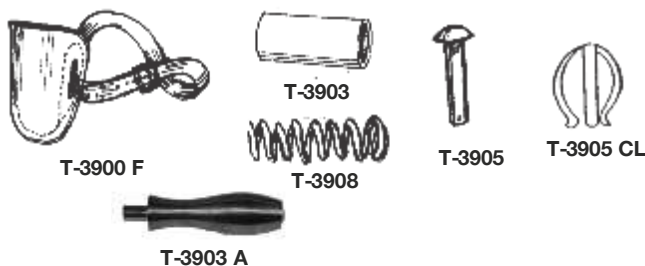

NUMBER	NAME OF PART	PRICE
T-3900 F	1909-27 Crank holder	7.95
T-3903	1909-22 Crank sleeve	2.25
T-3903 A	1911-14 Aluminum crank handle and pin.	Disc.
T-3905	Crank ratchet pin	.70
T-3905 CL	Crank ratchet jiffy pin	7.00
T-3906	1909-27 Ratchet for Hand Crank	20.00
T-3908	1909-27 Crank spring	.95

T Accessories

* Official Licensed Product
Ford Motor Company



T-3920 BS

T-3920 CS



T-3921 year



T-3926 A
T-3926 B

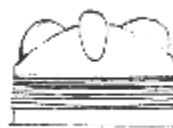

T-3926 C



T-3926 DBB
T-3926 DBC



T-3926 GWB
T-3926 GWC



T-3926 HB
T-3926 HC



A-18355 B
A-18355 C



T-18354 CW
T-18354 BW

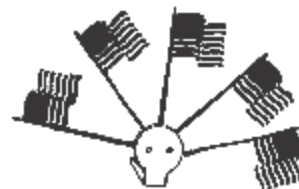

T-18800 TF

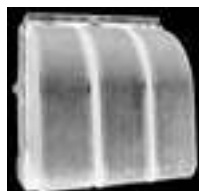

T-GWO-1
T-GWO-2



T-19528



T-19525



A-18775



T-3664 LF



T-5761 DX
(Ask about bulbs)



T-18200

NUMBER	NAME OF PART	PRICE	NUMBER	NAME OF PART	PRICE
T-3900 TPL	Thermostat plate, used to mount thermostat in outlet	14.95	T-3926 HC	Chrome hex cap, for black radiator shell cars, can be used with A-18355 C wings and motor meter	17.00
*T-3920 BS	1909-16 Die cut brass Ford script, 3 1/4" wide 7 1/4" long	13.00	T-3664 LF	1909-27 Model T license frame	7.50
*T-3920 CS	1916-27 Die cut brass chrome plated Ford script 3 1/4" wide 7 1/4" long	16.00	T-5761 DX	1924-27 Instrument panel dash light	35.00
T-3921 YEAR	1909-27 Year plates. 1909-16 Gold plated brass. 1917-27 Chrome over brass. Attach to radiator core with fine wire, wire not included	22.00 ea.	T-18200	Chrome windwing brackets clamp to round windshield frames only	110.00
T-3926 A	1909-12 Brass high fin radiator cap	16.00	*T-18354 BP	Junior motor meter, brass with plain rim, w/Ford script	57.00
T-3926 B	1913-16 Brass low fin radiator cap	19.50	*T-18354 BW	Junior motor meter, brass with wreath, Model T, w/Ford script	57.00
T-3926 C	1917-27 Brass with chrome plating low fin radiator cap	19.50	*T-18354 CP	Junior motor meter, chrome with plain rim, w/Ford script	57.00
T-3926 DBB	Brass dogbone radiator cap, for brass radiator cars, drilled for motor meter	25.00	*T-18354 CW	Junior motor meter, chrome with wreath, Model T, w/Ford script	57.00
T-3926 DBC	Chrome dogbone radiator cap, for black radiator shell cars, drilled for motor meter	28.00	A-18355 B	Brass wings for use with hex cap and motor meter on cars with brass radiator	23.00
T-3926 GWB	Brass gullwing radiator cap, for brass radiator cars. Specify plain or drilled.	25.00	A-18355 C	Chrome wings for use with chrome hex cap and motor meter on cars with black radiator shell	26.00
T-3926 GWC	Chrome gullwing radiator cap, for black radiator shell cars, drilled.	29.00	T-18800 TF	Flag set. Mounts between motormeter and cap	21.95
T-3926 HB	Brass hex cap, for brass radiator cars, can be used with A-18355 B wings and motor meter	16.00	*T-19525	1909-27 Oil Can	21.00
A-18775	Decal, Ford oval, magnetic and reflective	15.00	T-19528	1909-27 Oil Can Holder	11.00
			T-GWO-1	Gas-Water-Oil Cans (Mounts to running board or luggage rack) Unsoldered for display only	300.00
			T-GWO-2	Gas-Water-Oil Cans (Mounts to running board or luggage rack) Soldered and tested for use on car	380.00

Fan

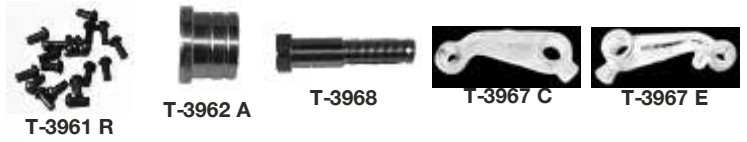
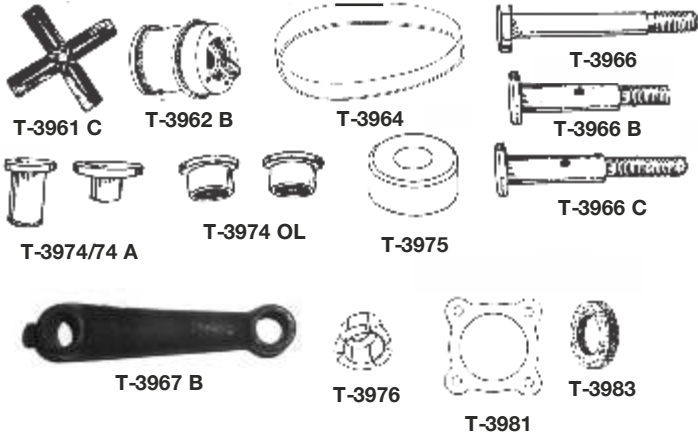

Heavy Duty Endless Fan Belts

Made of Neoprene impregnated polyester. Extremely durable and long lasting. Please measure before ordering, a dirty belt is not exchangeable.

NUMBER	NAME OF PART	PRICE
T-3962 A	1916-19 Fan hub cartridge with two sealed bearings. Easily replaces old bushings.	44.00
T-3961 C	1920-27 4-blade reproduction fan	11.95
T-3961 R	1909-20 Fan blade rivet kit.	2.00
T-3962 B	1920-27 Model T Fan Hub. Machined aluminum with modern sealed bearings.	65.00
T-3964 23	1909-16 23" belt	16.00
T-3964 25 7/8	1917-20 25 7/8" belt	16.00
T-3964 27	1921-25 27" belt	16.50
T-3964 32	1926-27 32" belt	17.50

The following belt sizes are for cars with water pumps. Please measure before ordering as a dirty belt cannot be exchanged.

NUMBER	NAME OF PART	PRICE
T-3964 30	30" belt	17.50
T-3964 31	31" belt	17.50
T-3964 28 1/4	28 1/4" belt	16.50
T-3964 33 1/8	33 1/8" belt	18.50
T-3964 33 3/4	33 3/4" belt	18.50
T-3964 36	36" belt	18.50

NUMBER	NAME OF PART	PRICE
T-3964 AE	Model T Endless Fan Belt - 23"	6.50
T-3964 BE	Model T Endless Fan Belt - 25 7/8"	6.75
T-3964 CE	Model T Endless Fan Belt - 27"	6.50
T-3964 DE	Model T Endless Fan Belt - 32"	8.50
T-3964 EE	Model T Endless Fan Belt - 28 3/4"	9.25
T-3964 FE	Model T Endless Fan Belt - 30"	7.50
T-3964 GE	Model T Endless Fan Belt - 31"	7.50
T-3964 HE	Model T Endless Fan Belt - 33 3/4"	8.00
T-3964 IE	Model T Endless Fan Belt - 36"	10.75
T-3964 JE	Model T Endless Fan Belt - 33 1/8"	8.50
T-3966	1909-20 Fan shaft	18.25
T-3966 B	1920-25 Fan shaft	21.00
T-3966 C	1926-27 Fan shaft	23.00
T-3967 B	1917-25 Fan bracket - used	15.75
T-3967 C	1913-16 Fan bracket - used (no dimple near small end)	18.00
T-3967 E	1909-13 Fan bracket - used (dimple near small end)	23.00
T-3968	1909-25 Fan bracket pivot bolt.	4.00
T-3973	1909-20 Fan bracket adjusting bolt.	1.35
T-3974/74 A	1917-20 Machined brass bushings for fan pulley	10.50 pr.
T-3974 OL	1920-27 Machined from modern bearing stock (Oilite)	5.00 pr.
T-3975	1917-27 Upper radiator thimble	1.75
T-3976	1917-27 Lower radiator thimble	1.75
T-3981	Fan pulley gasket	.35
T-3983	Fan shaft felt	.30

Radiator Shell and Radiator Apron

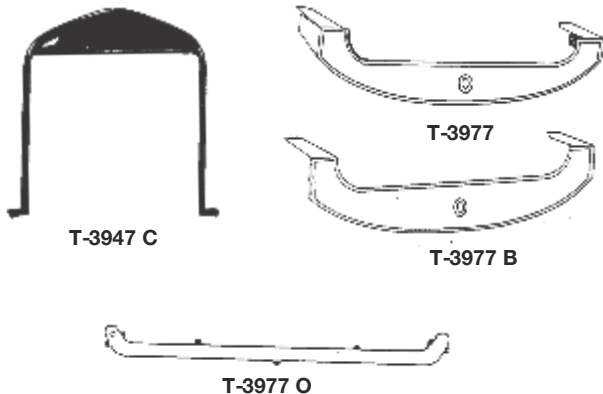

NUMBER	NAME OF PART	PRICE
T-3947 B	1917-23 Steel Radiator Shell Painted Black 2 pieces	175.00
T-3947 BC	1917-23 Steel Radiator Shell Chrome plated 2 pieces	225.00
T-3947 C	1923-25 Steel Radiator Shell	Disc.
T-3947 D	1926-27 Steel Radiator Shell Chrome Plated, not exact & non script.	Disc.
T-3947 DB	1926-27 Plain Radiator Shell (Not Chromed)	Disc.
T-3948 AL	1923-25 Radiator Shell Trim (LH)	13.50
T-3948 AR	1923-25 Radiator Shell Trim (RH)	13.50
T-3948 BL	1926-27 Radiator Shell Trim (LH)	13.50
T-3948 BR	1926-27 Radiator Shell Trim (RH)	13.50
T-3977	1923-25 Radiator Apron, none better	31.00
T-3977 B	1926-27 Radiator Apron, none better	39.00
T-3977 E	1916-23 Radiator apron 1 1/4" wide.	55.00
T-3977 O	1926-27 Radiator Apron, decorative strip	19.95

Radiator and Cooling System



Radiators

NUMBER	NAME OF PART	PRICE
T-3923	1911-12 Round tube radiator	1,160.00
T-3923 A1	1911-12 Flat tube radiator	1,096.00
*T-3923 A2	1913-14 Round Tube Radiator, script	1,160.00
*T-3923 A3	1913-14 Flat Tube Radiator, script	1,096.00
*T-3923 A4	1915-16 Round Tube Radiator, script	1,160.00
*T-3923 A5	1915-16 Flat Tube Radiator, script	1,096.00
T-3923 B	1917-23 Low Round Tube Radiator	885.00
T-3923 BF	1917-23 Low Flat Tube Radiator	790.00
T-3923 C	1923-27 High Round Tube Radiator	885.00
T-3923 CF	1923-27 High Flat Tube Radiator	790.00

The above radiators are USA made. The round tube is for authenticity. The flat tube cools better. Allow 2 weeks for shipping.

* A 7% Ford Motor Company licensing fee to allow the manufacturer to legally stamp the Ford Script into the top tank of the radiator is included in price.

**T-3923 BFE	1917-23 low flat tube radiator	690.00
**T-3923 CFE	1923-27 high flat tube radiator	690.00

**These radiators are not as detailed in appearance as the others, but are capable of cooling just as well. Does not have stabilizer bar across bottom.

NOTE: For identification the 1917-23 radiator core is 17" tall and the 1923-27 radiator core is 18 3/8" tall.

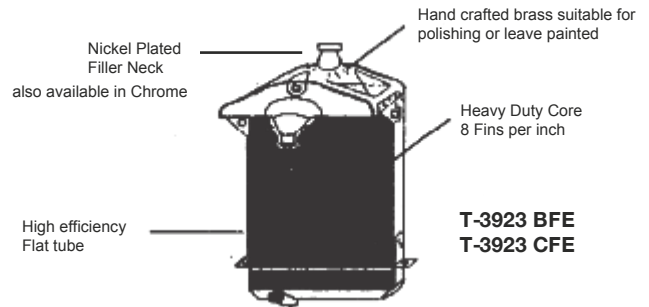
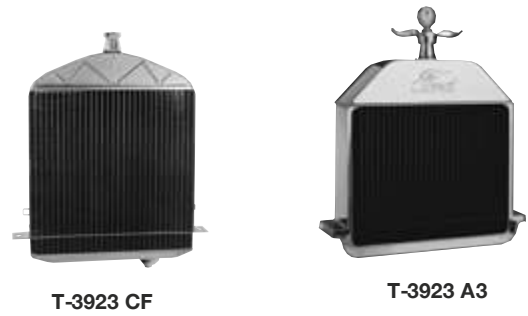

Each radiator is fitted into an original shell and pressure tested for leaks.

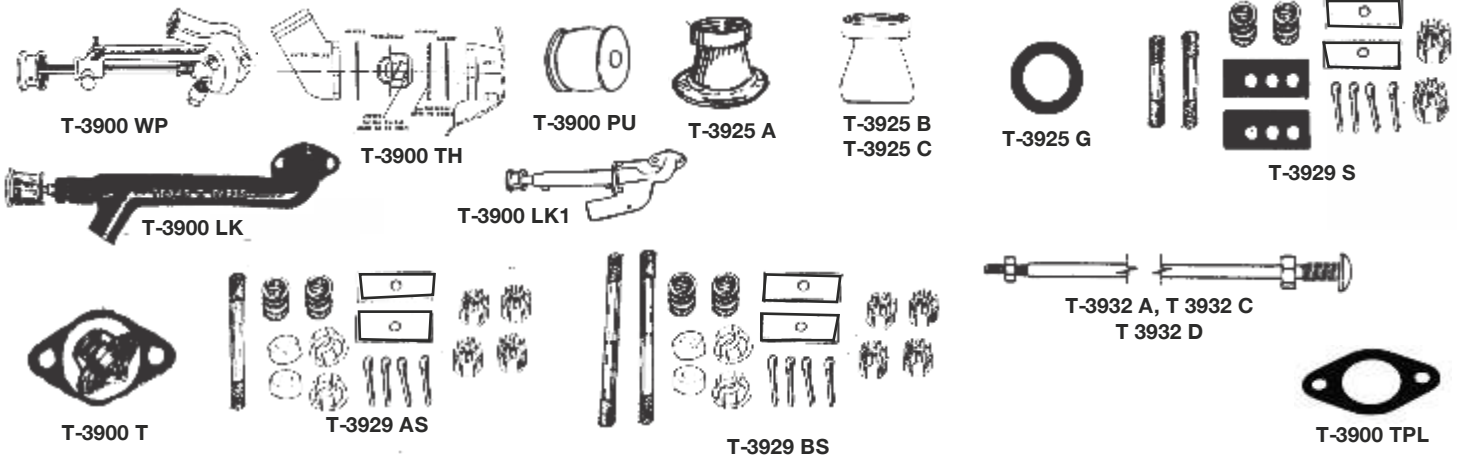

NUMBER	NAME OF PART	PRICE	NUMBER	NAME OF PART	PRICE
T-3900 LK	1909-27 Leakless water pump. Sealed bearings, stainless steel shaft w/impeller and mechanical seal. Supplied with a 180 degree thermostat. Guaranteed not to leak.	243.00	T-3925 A	1909-16 Brass filler neck	33.50
T-3900 PU	Water pump replacement pulley	12.00	T-3925 B	1917-27 Nickel filler neck	70.00
T-3900 T	1909-27 Thermostat for cars without water pump, 160 degrees.	9.00	T-3925 C	1917-27 Chrome filler neck	70.00
T-3900 TH	Thermostat Kit for Cars with water pump. Includes Anodized Aluminum plate and 180 degree Thermostat with gaskets. This kit normally solves most water pump problems.	9.00	T-3925 G	Radiator cap gasket	.35
T-3900 WP	1909-27 Water pump, with old style packing nut	180.00	T-3927 R	1909-27 Rubber Radiator Cap Gasket 5/32 thick - Install pointed side down	1.75
			T-3929 S	1909-19 Radiator mounting kit	15.00 set
			T-3929 AS	1920-25 Radiator mounting kit	15.75
			T-3929 BS	1926-27 Radiator mounting kit	15.75
			T-3932 A	1909-22 Radiator brace rod for wood dash	21.00
			T-3932 C	1923-25 Radiator brace rod	11.25
			T-3932 D	1926-27 Radiator brace rod	11.25

Radiator and Cooling System



(continued)

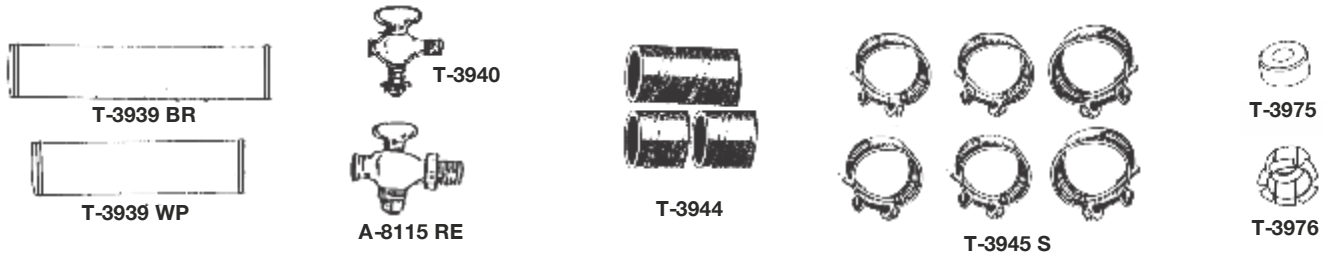

NUMBER	NAME OF PART	PRICE	NUMBER	NAME OF PART	PRICE
T-3939	1909-27 Steel water tube	7.95	T-3944	1909-27 Radiator hose	9.75
T-3939 BR	1909-16 Brass water tube w/o water pump	26.00	T-3945 S	1909-27 Radiator hose clamp set	5.75
T-3939 WP	1909-27 Water Pipe, cars with water pump	8.00	T-3975	Upper Radiator Thimble	1.75
T-3940	1909-27 Radiator drain petcock	9.50	T-3976	Lower Radiator Thimble	1.75
A-8115 RE	1909-27 Replacement petcock. Does not look like original style T-3940	7.50			

Firewall and Dash Shield

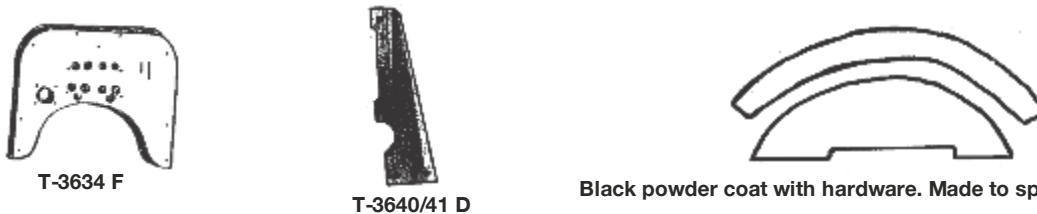

Black powder coat with hardware. Made to specifications.

NUMBER	NAME OF PART	PRICE	NUMBER	NAME OF PART	PRICE
T-3634 C	1913-14 Cherry plywood (3/4") with holes	120.00	T-3638 E6	1915 Early dash shield	22.00
T-3634 D	1915-16 Wood firewall	85.00	T-3638 E7	1915-17 Dash shield	22.00
T-3634 E	1917-21 Wood firewall. Fits cars without starters.	80.00	T-3638 E8	1917-18 Dash shield	22.00
T-3634 F	1918-23 Firewall wood - used on cars with starters	90.00	T-3638 E9	1918-19 Dash shield	22.00
T-3638 E5	1913-14 Dash shield	22.00	T-3640/41 C	1917-22 Dash brackets	13.95 pr.
			T-3640/41 D	1923-27 Dash Brackets	13.95 pr.

Muffler and Exhaust Pipe

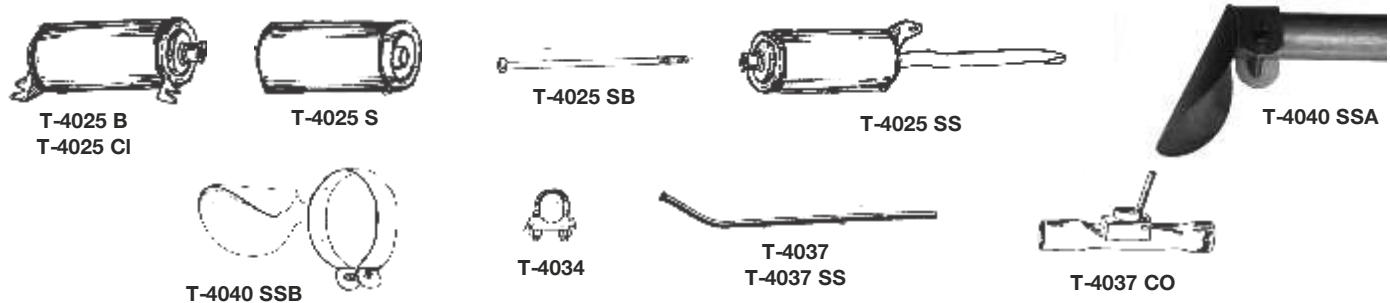

NUMBER	NAME OF PART	PRICE	NUMBER	NAME OF PART	PRICE
T-4025 B	1921-27 Original design muffler with heavy steel ends	39.50	T-4034	Muffler clamp, used only with T-4025 B muffler	1.25
T-4025 CI	1917-21 Original design muffler with cast iron ends	60.95	T-4037	Exhaust pipe - Aluminized steel	18.00
T-4025 S	Shell replacement kit for cast iron end muffler	32.00	T-4037 CO	1909-27 Model T exhaust pipe cut out & Aermore whistle adaptor	80.00
T-4025 SS	1909-27 Stainless steel muffler with 14" SS tail pipe to direct exhaust over rear end and away from spare tire.	96.00	T-4037 SS	1909-27 Stainless steel tail pipe	65.00
T-4025 SB	Muffler Shell Bolt	1.95	T-4040 SSA	1909-14 Stainless steel tail pipe exhaust deflector. Attaches to tail pipe to deflect much of exhaust down and away from car.	31.00
			T-4037 CO	1915-27 Stainless steel exhaust deflector. Attaches around muffler to direct exhaust away from car and spare tire.	33.00

Hoods

* Official Licensed Product
Official Merchandise of the Ford Motor Company

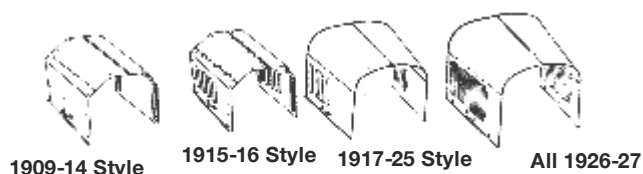

1909-14 Style

1915-16 Style

1917-25 Style

All 1926-27



T-4052



T-4052 B



T-4053



T-4053 B



T-4054



T-4056/57 MB



T-4056/57



T-4056/57 A



T-4056/57 B



T-4056/57 D

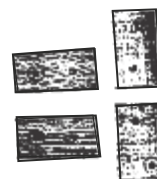

T-4073 A

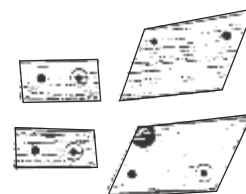

T-4073 B

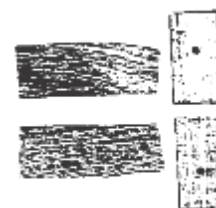

T-4073/6 C



T-4060 S



T-4002



T-4061 E, T-4061 G



T-4061 B



T-4060 D

NUMBER	NAME OF PART	PRICE	NUMBER	NAME OF PART	PRICE
T-4002	1916-27 Hood Retainer mounts on radiator shell	4.70	T-4056/57	1909-16 Wood Hood shelves for the early T	28.50 pr.
T-4050 09	Early 1909 Steel Stock Hood	345.00	T-4056/57 A	1917-23 Hood shelves	42.00 pr.
T-4050 09-12	1909-12 Aluminum Stock Hood	345.00	T-4056/57 B	1923-25 Hood shelves	42.00 pr.
T-4050 10-11	1910-11 Torpedo Aluminum Stock Hood	345.00	T-4056/57 D	1926-27 Hood shelves	47.50 pr.
T-4050 13-14	1913-14 Aluminum Stock Hood	345.00	T-4056/57 MB	1909-25 Hood shelf to engine pan mounting bolts and nuts	1.75 set
T-4050 110	1915-16 Aluminum Stock Hood 6 Louvers	345.00	T-4056/57 MB2	1926-27 Hood shelf bolt set	2.25 set
T-4050 111	1915-16 Steel Stock Hood, 6 Louvers	345.00	T-4060	1911-14 Hood former. Well made from pressed steel. Can also be used when building a speedster.	180.00
T-4050 1723	Low hood for 1917-23. 12" high at the front. Duplicate of original. Steel pressed handles and louvers.	345.00	T-4060 D	1916-27 Radiator shell lacing	4.75
T-4050 2325	High hood for late 1924-25. 13 3/8" high at the front. Duplicate of original. Steel pressed handles and louvers.	345.00	T-4060 R	Brass split rivets for cowl lacing and brake lining (24/pkg.)	1.35
T-4050 2627	1926-27 Hood - Duplicate of original.	345.00	T-4060 S	1916-27 Cowl lacing with rivets	6.95
T-4052	1911-15 Hood hook set	10.50 set	T-4061 B	1917-20 Rear Hood Retainer	6.00
T-4052 B	1917-27 Hood hook set	16.00 set	T-4061 E	1923-25 Rear Hood Retainer	Disc.
T-4053	1909-16 Hood hook spring	.50 ea.	T-4061 G	1926-27 Rear Hood Retainer	2.95
T-4053 B	1917-27 Hood hook spring	.50 ea.	T-4073 A	1915-22 Hood Blocks	9.50
T-4054	Leather hood corners	3.50	T-4073 B	1923-25 Hood Blocks	11.75
			T-4073/6 C	1926-27 Hood Blocks	13.00

Top Parts

* Official Licensed Product
David McNeil's Garage

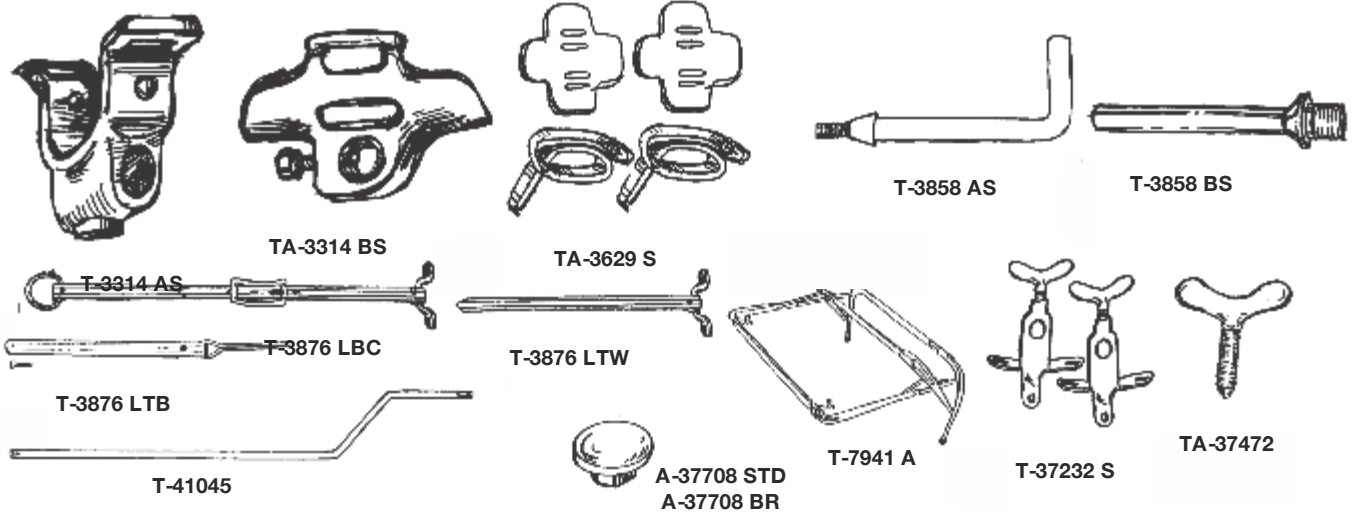

NUMBER	NAME OF PART	PRICE	NUMBER	NAME OF PART	PRICE
T-3314 AS	1909-22 Top saddles for L-shaped arm 5/8" hole	20.00 pr.	T-7941 B	1923-25 Roadster and Roadster pickup top assembly. Please allow 2-wk delivery	625.00
TA-3314 BS	1923-31 Top saddles for straight arm 1/2" hole	18.00	T-7941 C	1926-27 Roadster & Roadster pickup top assy. Please allow 2-wk. delivery	625.00
T-3314 CS	1913-21 Top saddle w/ 5/8 hole	19.00	T-7941 D	1917-22 Touring top assembly	895.00
TA-3629 S	1914-27 Top saddle pad set	16.00 set	T-7941 E	1923-25 Touring Top Assy. Please allow 2-wk. delivery	895.00
T-3858 AS	1909-22 L-shaped top saddle arms - Roadster	17.50 pr.	T-7941 F	1926-27 Touring. Please allow 2-wk. delivery	923.00
T-3858 BS	1923-27 Straight top saddle arms	14.00 pr.	T-37232 S	1923-27 Top hold down clamps. Holds top to windshield posts	52.00
T-3858 TS	1909-22 L-shaped top saddle arms - Touring	17.50 pr.	TA-37472	1923-27 Top clamping bracket thumbscrew	5.25
T-3876 LBC	1912-22 Rear curtain straps	49.95 pr.	A-37708 BR	1-1/2" Brass prop nut	9.25
T-3876 LTB	1912-22 Top bow side straps	12.00 pr.	A-37708 STD	1-1/2" Steel cadmium plated prop nut to be painted	6.25
T-3876 LTW	1912-22 Top to windshield (Strap with footman loop only)	21.50 pr.	T-41045	1926-27 Roadster Side curtain rods. Order 2 pair for touring	16.95 pr.
T-7940 J	1915-16 Touring Top bow metal socket assembly. Bows not included	550.00			
T-7941 A	1917-22 Roadster top assembly	625.00			

Horn

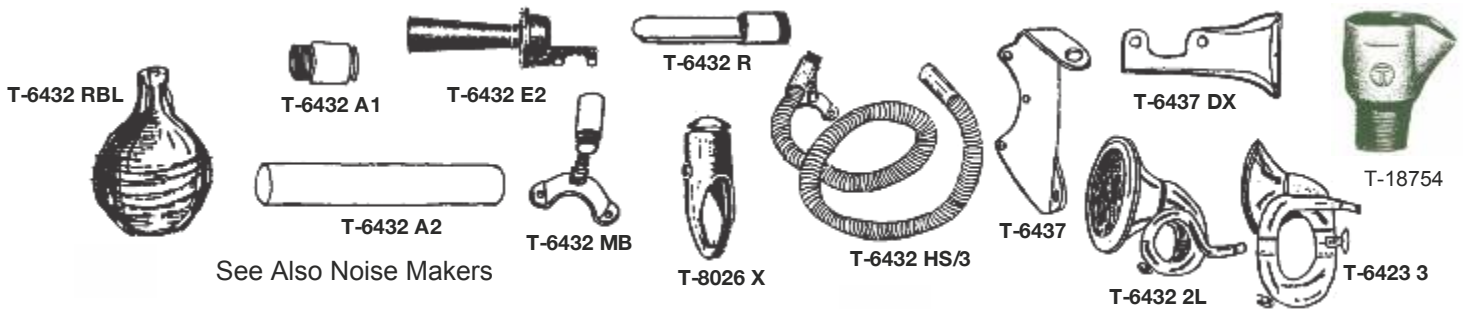

See Also Noise Makers

NUMBER	NAME OF PART	PRICE	NUMBER	NAME OF PART	PRICE
T-6432 A1	Short Horn Adapter that is soldered to horn reed	8.50	T-6432 RBL	Large rubber horn bulb	18.35
T-6432 A2	Threads onto short adapter to cover reed and hold rubber bulb or use as tubing connector	12.75	T-6432 RBS	Small rubber horn bulb. Fits 5/8 tube	16.75
T-6432 E2	1922-25 all new Model T horn w/authentic sound & bracket. Identical to original in appearance. Dependable electronic motor w/stainless diaphragm. Negative ground only	240.00	T-6437 DX	1926-27 Horn bracket - may require fitting	12.00
T-6432	1926-27 same as above with different mtg. bracket	240.00	T-6437	1917-25 Original design horn bracket Will fit all years.	15.00
T-6432 FT	Brass flex tubing, sold by the foot	15.75 ft.	T-8026 X	1917-27 Duplicate of original horn button assembly.	30.00
T-6432 HS/3	Horn set up. Includes large rubber bulb, mtg. bracket, flex tubing, adapters & reed. 3 feet long.	115.00	T-4037 CO	1909-27 Model T exhaust pipe cutout & Aermore whistle adapter	80.00
T-6432 MB	Horn bracket used to mount rubber horn bulb & flex	16.00	#12	Aermore exhaust whistle	225.00
T-6432 R	Brass horn reed	15.00	T-18753 KIT	Model T explosion whistle kit fits under spark plug	Disc.
			T-18754	Model T Explosion whistle adapter	14.75

Bumper

* Official Licensed Product
Ford Motor Company

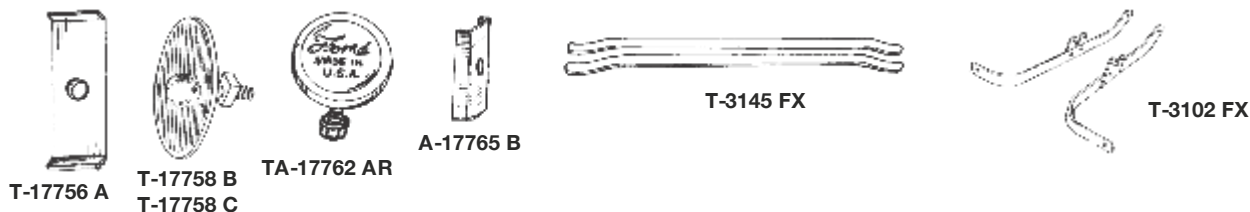

NUMBER	NAME OF PART	PRICE	NUMBER	NAME OF PART	PRICE
T-17756 A	1926-27 Bumper clamp backing plate	5.50	T-3102 FX	1926-27 Front bumper brackets	95.00 set
T-17758 B	1926-27 Outer bumper clamps, painted black w/bolt, w/nut and washer. Authentic design.	13.00	T-3102 SR	1926-27 Rear bumper bracket, solid bumper	185.00
T-17758 C	1926-27 Outer bumper clamps. Same as above except chrome plated.	15.00	T-3102 SR 2	1926-27 Rear bumper bracket for 4 pc. bumper	235.00
*TA-17762 AR	1926-27 Center bumper clamp. Ford script, made in USA.	9.75	T-3145 FX	1926-27 Model T bumper bars. Two stainless steel bars. Open end style. Show Quality.	280.00
A-17765 B	Backing plate for center bumper clamp	.95	T-3145 FXS	1926-27 4 pc. rear stainless steel bumpers	180.00

Patent Plates

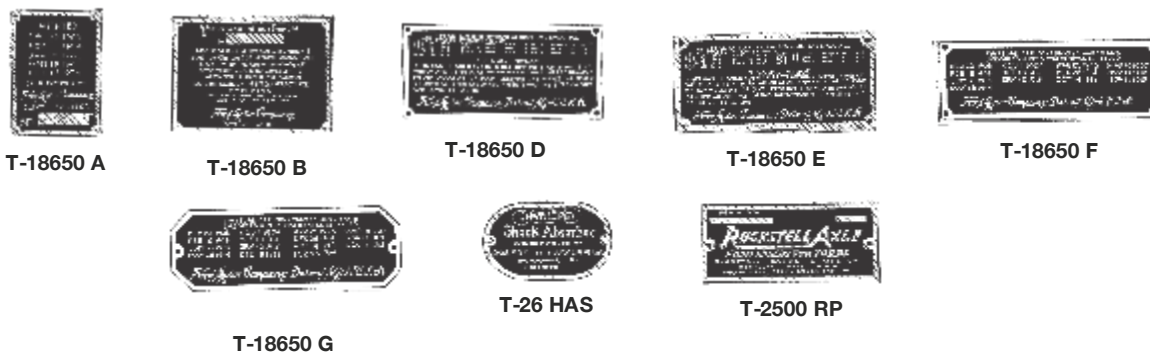

NUMBER	NAME OF PART	PRICE	NUMBER	NAME OF PART	PRICE
*T-18650 A	1909-11 Patent plates	5.95	*T-18650 F	1919-25 Patent plates	1.95
*T-18650 B	1911-12 Patent plates	5.95	*T-18650 G	1926-27 Patent plates	1.95
*T-18650 C	Late 1912 Patent plate	5.95	T-26 HAS	Hassler patent plate (shock absorbers)	5.95
*T-18650 D	1913-16 Patent plates	4.50	T-2500 RP	Ruckstell Axle patent plate (2 speed axle)	5.00
*T-18650 E	1917-18 Patent plates	3.95			

Battery Parts

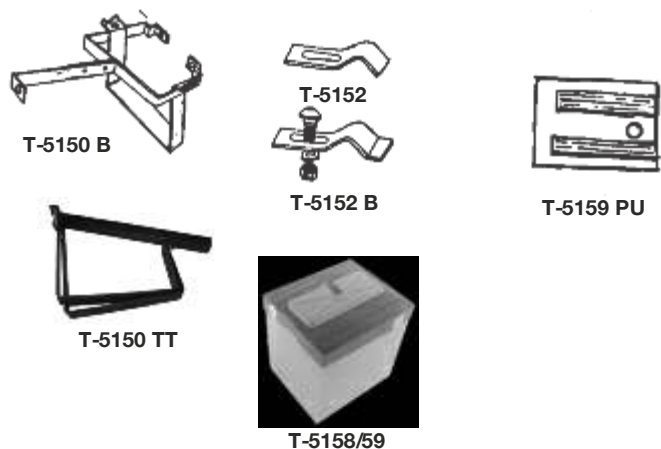

NUMBER	NAME OF PART	PRICE
T-5149	1919-27 Battery Box Spacer Board	11.00
T-5150 TT	1919-27 Ton truck battery mounting bracket assembly. Fits under runningboard brackets and runningboard on TT truck.	41.00
T-5150 B	Original Style Battery Carrier 1919-27	55.00
T-5152	1919-22 Battery clamp set w/ bolts & nuts	5.00
T-5152 B	1923-27 Battery clamp set w/ bolts & nuts	5.00
T-5159 PU	Pickup battery cover	53.50
T-5158/59	1923-25 Plain battery box	105.00

Spark Plugs

* Official Licensed Product
Ward Air & Accessories

NUMBER	NAME OF PART	PRICE
T-5200	1909-27 Model T Spark Plug Adapter. Use Modern Day 14mm Spark Plugs to obtain the Correct Heat Range	16.95
T-5200 PP	Piston Position sensor kit	3.00 ea.
T-5201	1909-27 Champion plug. Replacement type for the driving car	11.75 ea.
T-5201 M14	14mm Spark plug for use with adapter. Medium heat range	2.75 ea.
T-5201 R	1909-27 Motorcraft Replacement Plug	3.50 ea.
T-5201 X	1909-27 Champion X plugs. For the show car	26.95 ea.

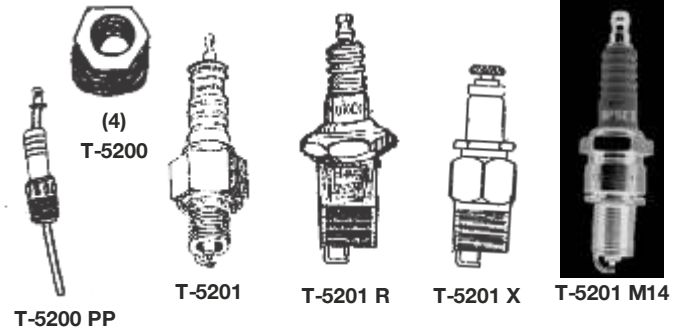

Wiring

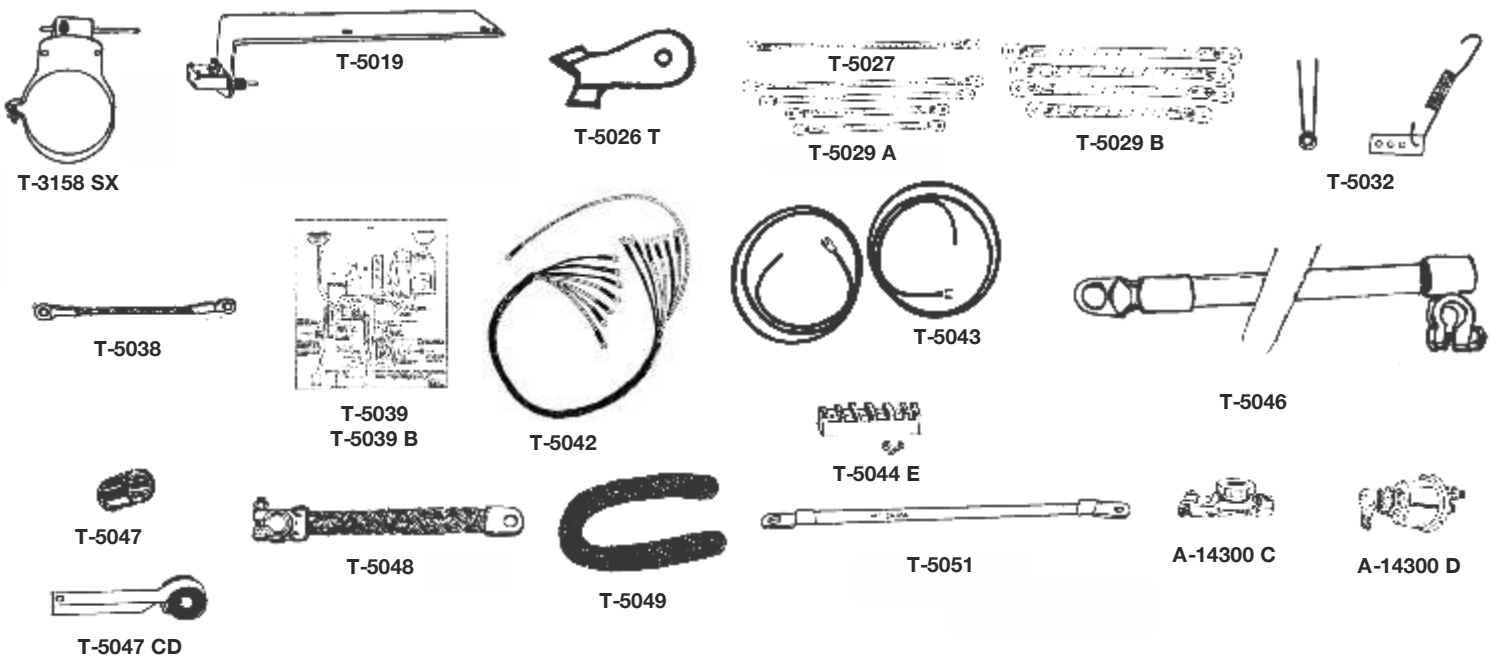

NUMBER	NAME OF PART	PRICE	NUMBER	NAME OF PART	PRICE
T-3158 BR	1926-27 Brake light switch	33.50	T-5041 A	1919-25 Light harness	23.50
T-3158 SX	1926-27 Stop light switch. Will fit any car with a starter.	28.95	T-5041 E	1926-27 Light harness	37.25
T-5019	1910-24 Stop light switch w/bracket	14.50	T-5042	1919-27 Switch wire	17.75
T-5026 T	1909-27 Wire terminals for spark plug wires	.50	T-5043	1915-27 Horn to terminal block wire	5.95
T-5027	1909-27 Magneto wire for cars without starters, 18" long.	4.50	T-5043 A	1913-25 Turn signal wiring kit	105.00
T-5029 A	1909-25 Spark plug wires (set of 4)	16.00	T-5043 B	1926-27 Turn signal wiring kit	175.00
T-5029 B	1926-27 Spark plug wires (set of 4)	14.00	T-5044 E	1923-27 Terminal block	9.00
T-5030	1909-22 Commutator wire loom w/o starter	18.50	T-5046	1919-27 Woven battery cable (29")	15.50
T-5031 A	1919-25 Commutator harness w/starter	28.00	T-5047 CD	1919-27 Battery cable frame support	4.75
T-5031 B	1926-27 Commutator harness	11.75	T-5047	Battery cable frame support grommet	1.25
T-5032	Tail light wire bushing	13.95	T-5047 OR	1919-27 Original style battery cable support bracket	16.50 ea.
T-5033 C	1919-27 Wiring Clips	7.75 set	T-5048	1919-27 Battery ground strap	8.50
T-5034	1909-15 Wire loom clip	9.50	T-5049	Battery cable fabric loom	3.50
T-5038	1919-27 Ammeter to switch wire	1.95	T-5051	1919-27 Braided switch to starter cable	11.25
T-5039	1919-25 Wiring Diagram, fully detailed 24" x 28"	6.50	A-14300 C	TERMINAL MOUNT BATTERY DISCONNECT SWITCH. Mounts to battery post. Turn 1/4 turn to cut power or remove knob to discourage theft.	7.95
T-5039 B	1926-27 Wiring Diagram, fully detailed 24" x 28"	6.50	A-14300 D	BATTERY DISCONNECT SWITCH. May be used with 6 or 12 volts. Put in main battery wire to disconnect power. Mounts on firewall or floorboard.	24.50

Coil Box & Ignition Switch

* Official Licensed Product
Wendell Motors & Equipment

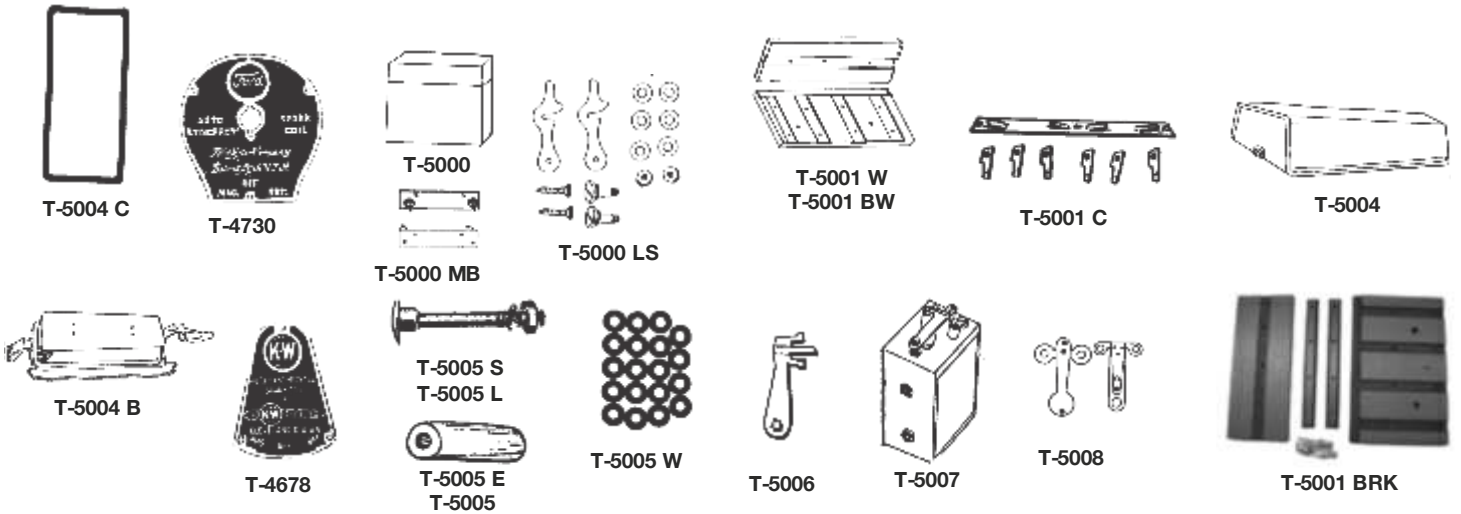

NUMBER	NAME OF PART	PRICE
T-4678	1911-14 Switch Plate for K-W Coil box	15.95
T-4725 XB	1917-23 Coil box to firewall bolts for wood firewall	7.00
T-4725 XF	1923-25 Coil box to firewall bolts for steel firewall	7.00
*T-4730	1914-22 Ford switch plate for Ford Coil box	11.95
T-5000	1910-13 Wood coil box, Kingston style	198.00
T-5000 H	1914-27 Heinze style wood coil box, unfinished	169.95
T-5000 MB	Bracket that mounts wood coil box to firewall.	16.00
T-5000 LS	Brass coil box latch set. Mounts wood coil box lid to wood coil box.	14.00
T-5001 C	1915-27 Coil box contact	9.50
T-5001 W	1915-25 Coil box wood, plywood.	15.25
T-5001 BW	1926-27 Coil box wood, plywood.	16.50
T-5001 RKW	1913-25 Rewood kit made from water proof material. Eliminates misfiring. Contains back, bottom, rivets, fasteners & diagram made to correct specifications. Insulates thousands of volts even when wet	65.00
T-5001 BRK	1925 (Late)-27 Coil box rebuild kit with waterproof material	65.00
T-5001 HW	1915-25 Coil box wood, hardwood.	24.50
T-5001 HBW	1926-27 Coil box wood, hardwood.	26.50
*T-5004	1914-25 Coil box lid	29.00
T-5004 B	1926-27 Coil box lid	27.00
T-5004 C	1926-27 Coil box lid gasket	2.00

NUMBER	NAME OF PART	PRICE
T-5005	1915-25 Porcelain tube	1.20 ea.
T-5005 E	1909-14 Glazed coil box tube	2.60
T-5005 L	1909-25 Coil box copper plated terminal bolts & nuts 2 1/8" long (10 pc. set)	3.95 set
T-5005 S	1926-27 Coil box copper plated terminal box bolts, nuts, 1 1/16" (10 pc. set)	3.25 set
T-5005 W	Coil box tube insulators (20 pc. set)	2.25 set
T-5006	1914-22 Switch Key	5.75
T-5007	1909-27 K & W coil, plastic cover	75.00
T-5007 BRN	1914-27 Coil box brass nuts. Conducts electricity better than steel nut. 18 pc.	1.95 set
T-5007 HM	Same as T-5007 RBO except that it has labeled screw on terminals for hit or miss engines.	75.00
T-5007 N	All the nuts needed to mount points to one coil.	1.25
T-5007 RB	1909-27 Later style wood coil. Rebuilt and refinished with new capacitor. EXCHANGE ONLY. Must have rebuildable core with complete top hardware, including points & nuts. Wood must be refinishable. \$20.00 Core charge.	55.00
T-5007 RBO	1909-27 K & W coil rebuilt. All new parts including wood cover. Uses old internal original windings. Exchange only.	75.00
T-5007 SP	Spring, coil point bridge spring	1.75
T-5007 W	1909-27 Coil with Wood Cover	80.00

Coil Box & Ignition Switch

* Official Licensed Product
Official Ford & Mercury

Continued



T-5009



T-5008 CAP



T-5012 A



T-5012 RKC



T-5012 RKP



T-5012 B



T-5012 T



T-5013



T-5014 RE



T-5013 IP



T-5013 KF



T-5015



T-5016

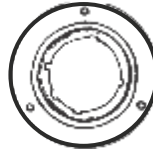

T-5017



T-5007 HM



T-5016 OR



T-5014 TFK

NUMBER	NAME OF PART	PRICE	NUMBER	NAME OF PART	PRICE
T-5008	1904-27 Coil points K & W	36.75 set	T-5012 T	1919-27 Switch Tumbler	Disc.
T-5008 CAP	Replace your own coil condenser with new heavy duty capacitors.	2.25	*T-5013	1923-27 Switch key (specify number 51 thru 74)	8.00 ea.
T-5009	1909-27 Model T Ignition coil tester. Uses your 6 volt or 12 volt battery to properly set the amperage draw of the coil	135.00	T-5013 IP	1919-25 Depot Hack & truck instrument panel to mount switch & ammeter	55.00
T-5009 DLX	1913-27 Coil tester. Makes same tests as Ford testers. Use to setup points & check coils. Ultimate "STROBO Spark" coil tester. Uses 120 volts	349.95	T-5013 KF	Leather key fob	2.25
T-5009 M	1909-27 Magneto tester, checks voltage and condition in the car. DUE IN JULY 2006.	170.00	T-5014 RE	1919-27 Starter switch replacement USA mfg.	21.95
T-5012 A	1919-25 Black Switch Assy. w/o Ammeter	75.00	T-5014 TFK	Inline safety fuse mount - weather proof	10.00
T-5012 B	1926-27 Chrome Switch Assy. w/o Ammeter	75.00	T-5015	1923-27 Starter switch extension	4.50
T-5012 RKC	1919-27 Dash mount switch repair kit, clip type	Disc.	T-5016	1926-27 Ammeter 20-20 (A-10850)	8.25
T-5012 RKP	1919-27 Dash mount switch repair kit, pin type.	Disc.	T-5016 OR	1919-25 Authentic USA ammeter script	69.95
			T-5016 ORL	Same as above with light, 6 or 12 volt	73.95
			T-5017	1926-27 Ammeter adapter ring	
			T-5017 MB	Adapts 1926-27 ammeter to 1919-25 dash	3.95
				Ammeter adapter ring screw set	.55 set

Runningboards and Splash Shields

* Official Licensed Products
Ford Motor Company

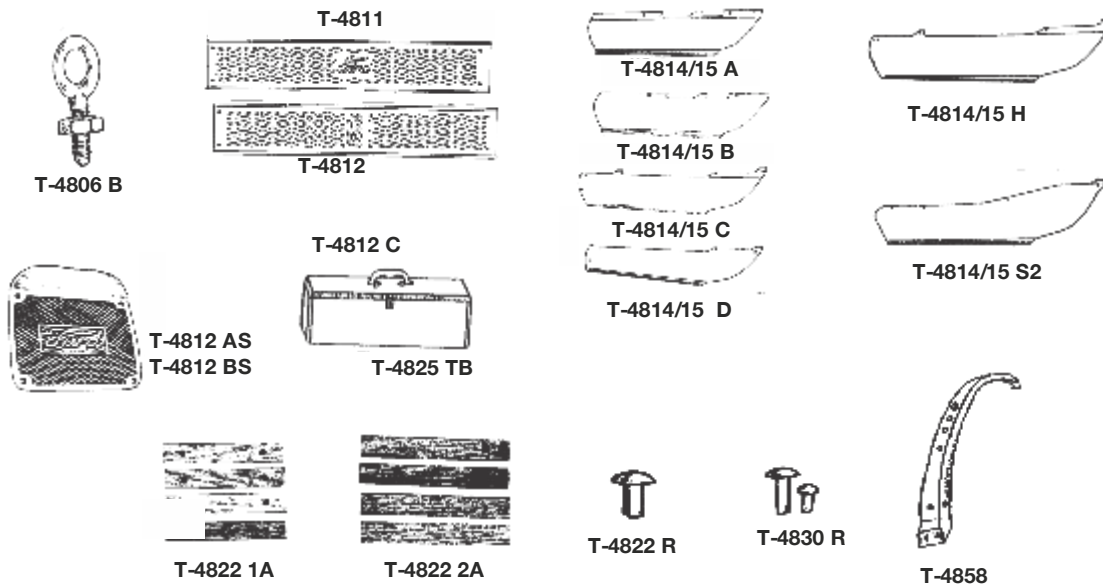

NUMBER	NAME OF PART	PRICE	NUMBER	NAME OF PART	PRICE
T-4806 B	1909-25 Fender eyebolt	9.00	T-4814/15 D	1917-23 Sedan, Runningboard Splash aprons. Duplicate of original.	185.00 pr.
T-4822 1A	1917-25 Runningboard blocks 7 3/8" long	9.00	T-4814/15 E	1926-27 All cars, Runningboard Splash aprons. Duplicate of original.	200.00 pr.
T-4822 2A	1926-27 Runningboard blocks 9 1/8" long	9.00	T4814/15 H	1917-25 Depot Hack Runningboard Splash aprons. Duplicate of original	200.00 pr.
T-4858	1926-27 Front Fender Brace	37.95 ea.	T-4814/15 S2	1924-25 Sedan Runningboard Splash aprons. Duplicate of original	185.00 pr.
*T-4811	1911-12 Runningboards	160.00 pr.	T-4816/17	1916-21 Runningboard truss rods with hardware.	75.00 pr.
*T-4812	1913-25 Runningboards	160.00 pr.	T-4816/17 E1	1909 Runningboard truss rods.	75.00 pr.
*T-4812 AS	Aluminum step plate 6 1/2 x 8 3/4" with Ford Script in block	17.50 ea.	T-4816/17 E2	1910-15 Runningboard truss rods with hardware.	75.00 pr.
*T-4812 BS	Brass step plates with Ford Script in block	68.00 ea.	A-16400 BT	Step plate screws, nuts & washers s/s (Pkg. of 8)	1.80
*T-4812 C	1926-27 Runningboards	160.00 pr	T-4822 R	1923-27 Runningboard bracket rivet set	5.50 set
T-4813 BS	Modern Runningboard to bracket bolt set	3.00	T-4825 TB	Tool box - heavy duty for Model T runningboard 19" L x 6" W x 6 1/2" H	80.00
T-4814/15 A	1912-14 Runningboard splash aprons Duplicate of original	165.00 pr.	T-4830 R	1917-25 Fender bracket rivets (10 pc)	2.50
T-4814/15 B	1915-16 Runningboards splash aprons. Duplicate of original.	165.00 pr.			
T-4814/15 C	1917-25 Touring and Roadster runningboard splash aprons.				

Door

* Official Licensed Product
Ward McMillan Company



T-5205 X

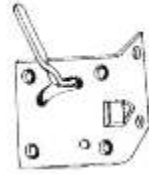

T-5679 AX & BX
 T-5680 AX & BX



T-5680 EX



T-8398



T-5679 HL



T-8399



T-17261 BX



T-19101



T-8320 BX



T-5680 HR



T-45225 A & B



T-45226

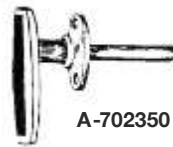

A-702350 P



A-45985



T-702350 HMH

NUMBER	NAME OF PART	PRICE	NUMBER	NAME OF PART	PRICE
T-5205 X	1915-27 Open car door hinge pins	.95 pr.	A-45983 PU	1926-27 Coupe & Tudor, 1928-29 Closed Cab Pickup window channel felt kit.	55.00 kit
A-35615	1926-31 Open car door hinge pins	1.95	A-45985	1919-31 Sponge rubber that glass rolls into on closed cars	2.25 ea.
T-5679 AX	1917-25 Left open car door latch	28.00	A-80055	1926-27 Coupe & Tudor, 1928-29 Closed Cab Pickup door latch repair kit. Complete with all springs & rivets to rebuild both latches.	14.95 set
T-5679 BX	1926-27 Left open car door latch	28.00	A-80301 L	1926-27 Coupe & Tudor, 1928-29 Closed Cab Pickup left hand upper door window frame.	60.00 ea.
T-5679 HL	Latch, use on homemade bodies with wooden doors with inside handles. Left side	17.50	A-80301 R	1926-27 Coupe & Tudor, 1928-29 Closed Cab Pickup right hand upper door window frame.	60.00 ea.
T-5680 AX	1917-25 Right open car door latch	28.00	A-80303	1926-27 Coupe & Tudor, 1928-29 Closed Cab Pickup rubber body plug. Plugs the hole above the outside door handle.	6.00 ea.
T-5680 BX	1926-27 Right open car door latch	28.00	A-80330 AR	1926-27 Coupe & Tudor, 1928-29 Closed Cab Pickup four hole dovetail.	3.00 ea.
T-5680 EX	1915-27 Door handle extension	7.25 ea.	A-80331	1926-27 Coupe & Tudor, 1928-29 Closed Cab Pickup striker, 2 pc.	10.50 ea.
T-5680 HR	Latch, use on homemade bodies with wooden doors with inside handles. Right side	17.50	A-80332	1926-27 Coupe & Tudor, 1928-29 Closed Cab Pickup stamped steel part that holds door bumper	4.00 ea.
T-8320 BX	1922-27 Closed car door lever anti rattler, Same as A-46273.	3.50 pr.	A-80333	1926-27 Coupe & Tudor, 1928-29 Closed Cab Pickup female dovetail.	10.50 ea.
T-8398	1926-27 Closed car top window cushion	2.85 ea.	A-80334	1926-27 Coupe & Tudor, 1928-29 Closed Cab Pickup striker shield mounts to door jam.	4.95 ea.
T-17261 BX	1915-27 Inside door handle knob for closed cars	5.25			
T-19101	Closed car window riser handle	7.00			
T-45225 A	1914-22 Upholstery End Caps	2.50 ea.			
T-45225 B	1922-25 Upholstery End Caps	7.85 ea.			
T-45226	Hydem Welt End Cap	3.50 ea.			
A-702350 P	1926-27 Closed car door handle with black insert like original	29.95			
T-702350 HMH	Handle steel 3-1/2 x 3/4 x 3" long, 5/16" square shaft	12.00			

Starter

* Official Licensed Product
Ward Motors Company



T-3380



T-3381

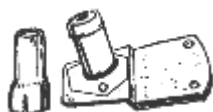

T-5014 RE



T-5015



T-5018



T-5020



T-5108 INS



T-5021



T-5021 PS



T-5022



T-5023-4-5



T-5056



T-5059



T-5099 R



T-5104



T-5105



T-5106



T-5107



T-5108



T-5109



T-5110

NUMBER	NAME OF PART	PRICE	NUMBER	NAME OF PART	PRICE
T-3380	1919-27 Starter Drive Cover	9.85	T-5023	1919-27 Starter Bendix drive gear	22.50
T-3381	1919-27 Starter drive cover gasket	.50	T-5023-4-5	Starter Bendix bolt and washer kit	2.75
T-5014 RE	1919-27 Model T Replacement Starter Switch. USA made switch that is readily available and is assembled to a special bracket that are made to work with it. Not identical in appearance to original. Made for the person who tours. Much more durable than T-5014. Includes extension.	21.95	T-5025	1919-27 Starter drive lock-washers	.45 ea.
T-5015	1923-27 Starter switch extension	4.50	T-5056	1919-27 Starter motor gasket	.95
T-5018	1919-27 Starter Drive, with spring, drive head and bolts. New	75.00	T-5059	1919-27 Starter drive cover screw set	1.40
T-5018 RB	1919-27 Rebuilt Starter Bendix. Does not have spring or bolts on either end. Exchange	65.00	T-5059 SS	1919-27 Special socket head cap screw and allen wrench set for starter drive cover. Makes screw installation easier.	3.00
T-5019 DH	1919-27 Starter Drive Head. Fits on the end of the starter shaft	9.00	T-5099 R	1919-27 Starter. Rebuilt, w/o Bendix. Exchange only or include \$100.00 core charge w/ rebuildable unit. Starter band not included.	195.00
T-5020	Starter Bendix Key	.35	T-5104	1919-27 Starter brush set	12.95
T-5021	Starter Drive Sleeve. Fits on the end of the starter drive. Spins on the starter shaft and often breaks.	8.00	T-5105	1919-27 Rear starter bushing	7.35
T-5021 PS	1919-27 Starter Bendix collar spring pin	4.50	T-5105 SK	1919-27 Shortened rear starter bushing with seal. Replaces original style T-5105 to prevent oil leaks.	19.00
T-5022	1919-27 Starter Bendix Spring	9.95	T-5106	1919-27 Front starter bushing	4.75
			T-5107	Starter Field Coil	63.00
			T-5108	1919-27 Starter brush plate insulators.	3.00
			T-5108 INS	1919-27 Starter brush plate insulators, made out of insulating material. Replaces T-5108	15.50
			T-5109	1919-27 Starter terminal outer insulator	2.50
			T-5110	1919-27 Term. Inner Insulator Starter & Generator	.20

Generator

* Official Licensed Product
Wendell Motors & Equipment

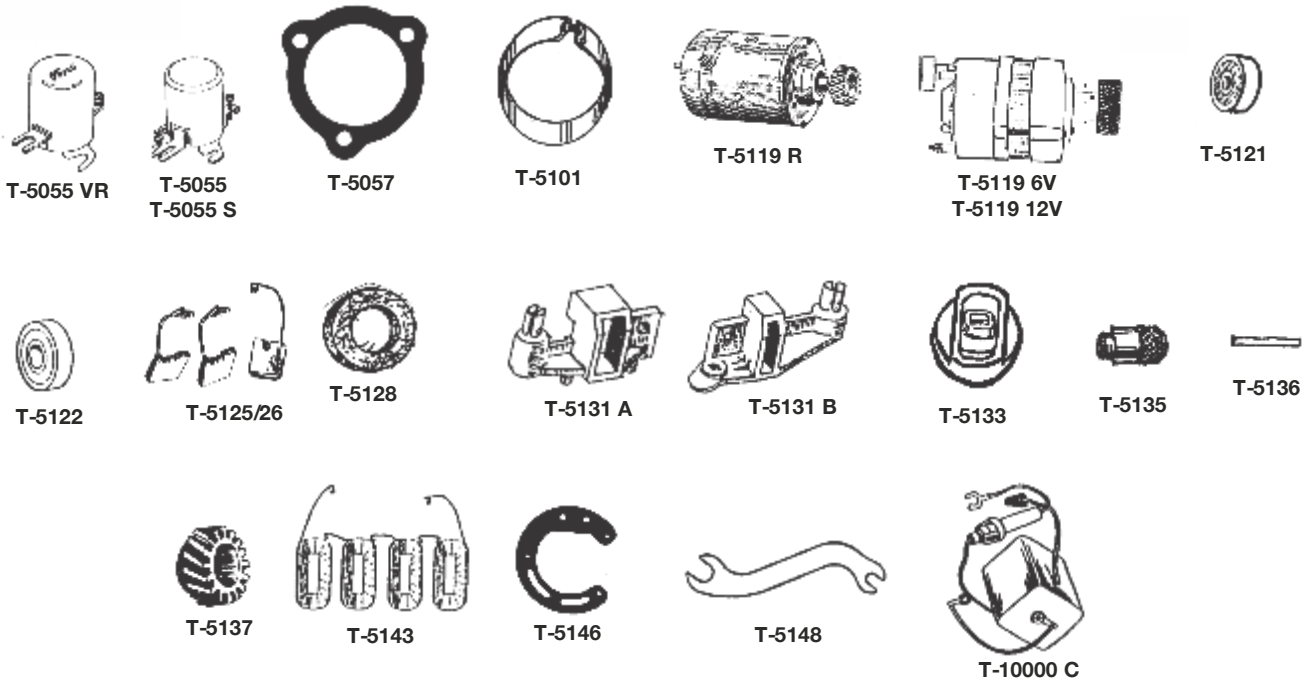

NUMBER	NAME OF PART	PRICE	NUMBER	NAME OF PART	PRICE
*T-5055 VR	Electronic voltage regulator 6 volt negative ground	69.00	T-5121	1919-27 Small generator bearing	4.75
T-5055 VR8	Electronic voltage regulator 8 volt negative ground	89.00	T-5122	1919-27 Large generator bearing (B-7600)	4.00
T-5055	1919-27 Generator cut out, original style	24.00	T-5125/26	1919-27 Brush set	7.00
T-5055 S	1919-27 Generator Cutout (semi conductor type), Identical to original exterior dimensions and duty. 6 volt negative ground	39.00	T-5128	1919-27 Generator felt	.40
T-5057	1919-27 Generator mounting gasket	.75	T-5131 A	1919-27 Large Generator brush holder	8.50
T-5101	Cover Band for starter & generator	8.75	T-5131 B	1919-27 Small Generator brush holder	7.50
T-5119 R	1919-27 Rebuilt generator w/o cutout, and drive gear. \$60.00 core charge without rebuildable unit	205.00	T-5132	1919-27 Generator brush holder insulators made to original specifications out of modern electrical insulating material replaces T-5146.	11.75 pr.
T-5119 E12	12 volt alternator for early cars without place for generator. Complete with brackets	275.00	T-5133	1919-27 Generator Terminal Insulator	2.50
T-5119 6V	Alternator - 6 volt with regulator. Mounts without modification	225.00	T-5135	1919-27 Generator twist oiler	6.00
T-5119 12V	Alternator - 12 volt with regulator. Mounts without modification	225.00	T-5136	1919-27 Generator drive gear pin	.25
T-5119 RE 6V	6 volt regulator for alternator	45.00	T-5137	1919-27 Generator drive gear	18.95
T-5119 RE 12V	12 volt regulator for alternator	45.00	T-5143	Generator field coils	48.00
			T-5146	1919-27 Generator brush holder insulators (2 required) made correctly.	3.00 pr.
			T-5148	Model T generator third brush wrench	10.25 ea.
			T-10000 C	Power Converter 6V to 12V for radio or CB, negative ground. Heavy duty.	99.95

Carburetor

* Official Licensed Product
Small Motor Components

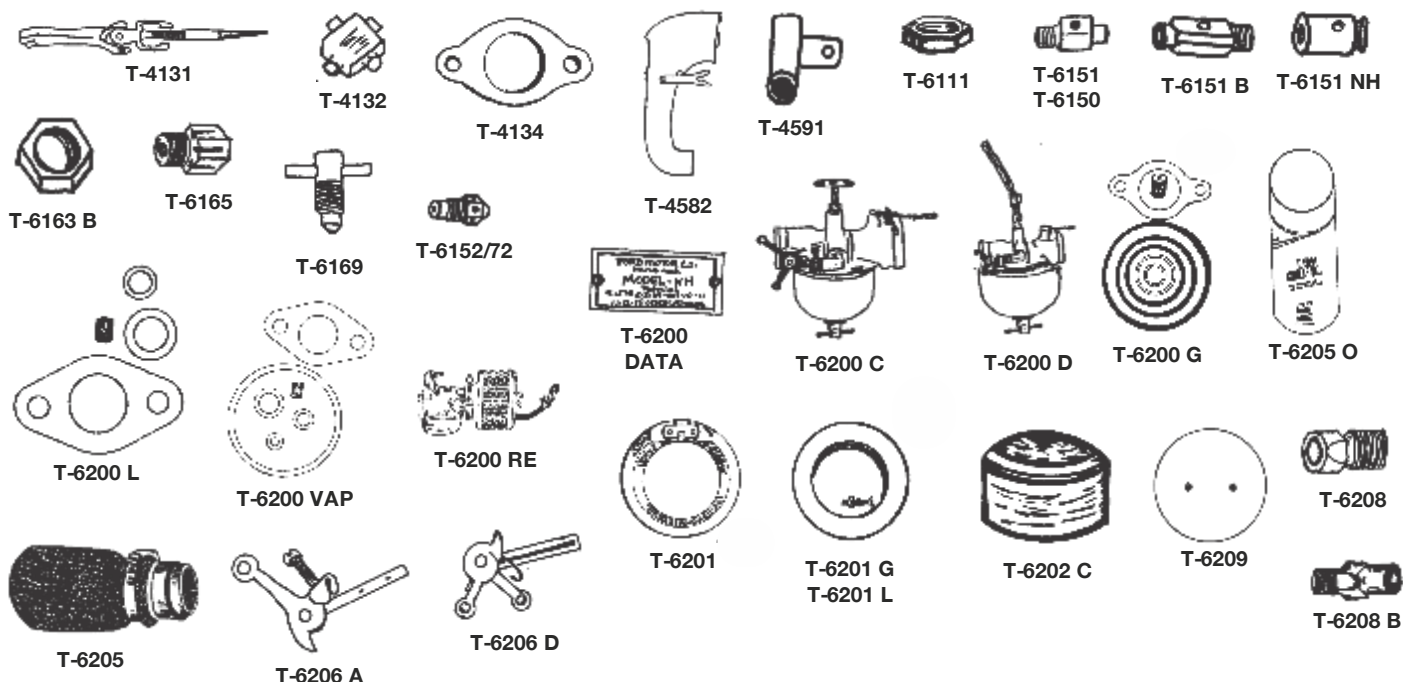

NUMBER	NAME OF PART	PRICE	NUMBER	NAME OF PART	PRICE
T-4131	1926-27 Choke Rod Sleeve U-Joint Spider and needle	25.50	T-6200 C	1920-25 Carburetor, absolutely authentic for 1923-25 cars but may be used on earlier cars as well. Equipped with long choke and throttle levers and flat spray needle yoke. Data plate must be ordered separately.	260.00
T-4132	1926-27 U-Joint spider	1.25	**T-6200 C REB	1920-25 Rebuilt NH carburetor. Core required	120.00
T-4134	1909-27 Carb to manifold gasket	.35	T-6200 D	1926-27 Carburetor, equipped with short yoke and throttle levers and swivel spray needle yoke. Data plate must be ordered separately.	270.00
T-4452	1914-21 Ford G carburetor spray needle assy.	9.00	**T-6200 D REB	1926-27 Rebuilt carburetor with swivel top. Core required.	125.00
T-4471	1912-19 Holley Brass Clamp Adjusting Nut	4.50	T-6200 DATA	NH carburetor, data plate	1.50
T-4472	Model G Holley Bowl Nut (1-1/4 Hex)	11.00	T-6200 NH	1920-26 Ford NH carburetor gasket set	2.00
T-4582	1912-27 Steel pipe that runs from manifold to carburetor to preheat air	12.95	T-6200 G	1913-21 8 pc. gasket set for Model G carburetor	2.25
T-4591	1926-27 Choke rod sleeve	2.75	**T-6200 K4 REB	Kingston L-4 Rebuilt Carburetor w/ exchange	150.00
T-6111	1913-20 Kingston L-2 Bowl Nut (7/8 Hex)	7.25	**T-6200 KL REB	Kingston L Rebuilt Carburetor w/ exchange	185.00
T-6150	1917-20 Kingston L-2 Drain Body	8.00	T-6200 L-4	1921-26 Kingston L-4 gasket set	2.00
T-6151	1920-26 Kingston L-4 Drain Body	8.00	T-6200 L	1912-21 Kingston model L gasket set	2.00
T-6151 B	1923-27 Holley NH Drain Body (Thread)	8.00	T-6200 NHR	NH carburetor data plate rivets	.90 pr.
T-6151 NH	1920-21 Holley NH Drain Body (Solder)	7.85	T-6200 RE	Model T replacement carburetor. Hooks up to throttle linkage & choke. Adjustment under hood. Complete with air filter. Increase power & gas mileage.	215.00
T-6152/72	Kingston float valve and seat, model L-4	10.75	T-6200 VAP	Vaporizer gasket set	2.00
T-6161	1910-25 Kingston L, L-2, L-4 carburetor spray needle assy.	17.50	T-6201	1916-27 Carburetor float, small bowl	17.25
T-6163	1921-25 Kingston L-4 Bowl Nut (3.4 Hex)	7.50	T-6201 G	Holley "G" alcohol proof float	14.00
T-6163 B	1921-25 Kingston L-4 Bowl Nut (15/16 Hex)	7.50	T-6201 L	Kingston L-2 alcohol proof float	14.00
T-6164	1909-27 Kingston Carburetor Choke Spring	1.25	T-6202 C	NH Carburetor bowl	8.00
T-6165	1915-26 Kingston L-4 Spray Needle Nut	7.25	T-6203	NH Carburetor bowl gasket	.40 ea.
T-6169	1915-19 Kingston L-4 Drain Needle	7.00			
T-6169 B	1914-27 Holley G, NH, Vaporizer Drain Needle	9.00			

**Cores must not be excessively rusty, cracked or have stripped threads.

Carburetor (continued)

* Official Licensed Product
Ford Motor Company

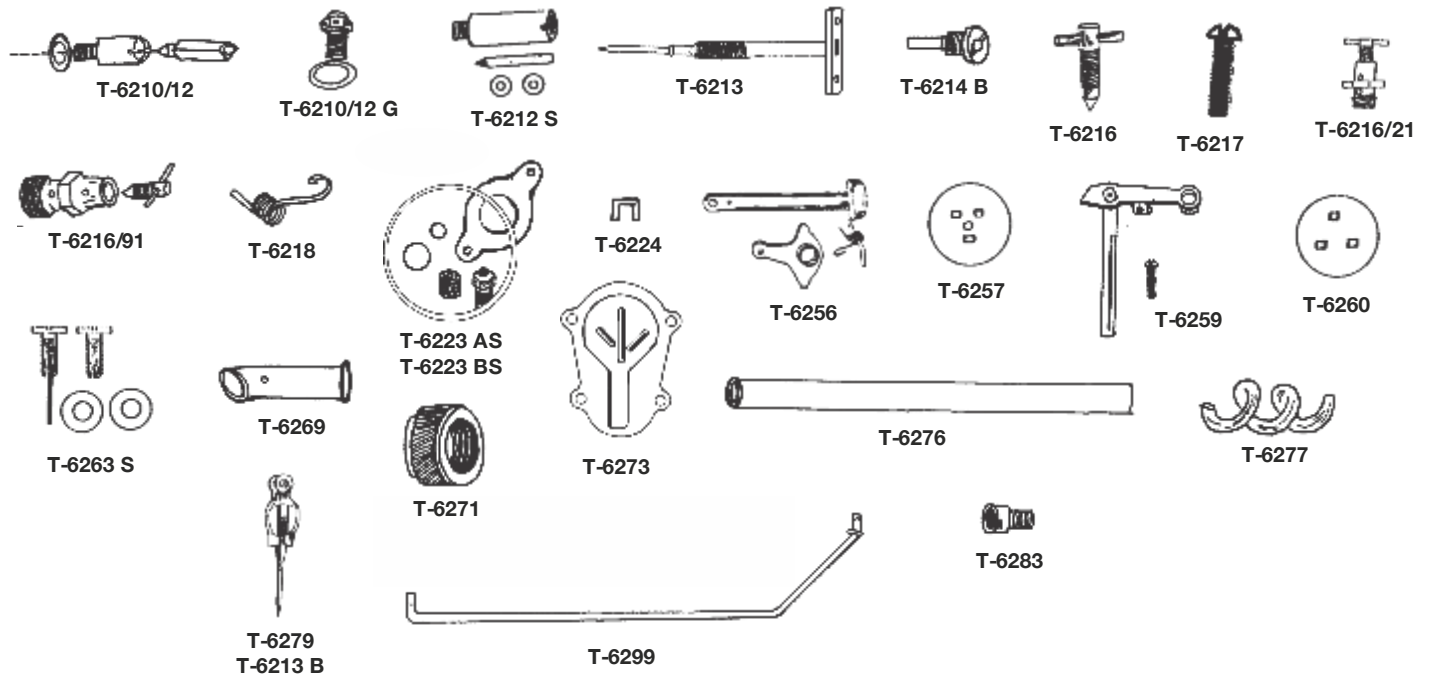

NUMBER	NAME OF PART	PRICE	NUMBER	NAME OF PART	PRICE
T-6205	1919-27 Small bowl carburetor air filter. Machined aluminum throat with foam filter and spring which holds the unit on by putting pressure on the transmission cover & carburetor. Complete & ready to install, oil included	38.00	T-6213	1920-25 Spray needle	11.00
T-6205 F	Foam filter replacement element for T-6205	10.95	T-6213 B	1925-27 Spray needle used with choke rod sleeve and spider	14.00
T-6205 O	Foam filter oil for T-6205, aerosol	7.50	T-6214 B	1920-26 Spray nozzle	6.00
T-6206 A	1914-23 NH Throttle Shaft Lever	14.75	T-6216/21	1920-26 Model NH drain valve and plug set	11.75
T-6206 B	1914-23 NH Choke lever shaft & spring	14.75	T-6216/91	Vaporizer drain valve assy.	12.25
T-6206 C	1923-26 NH Throttle Shaft Lever	14.75	T-6216	1916-26 NH Carburetor drain valve plug	6.50
T-6206 D	1923-26 NH Choke lever shaft & spring	14.75	T-6217	1911-26 Carburetor throttle lever stop screw, Ford NH	.85 ea.
T-6207	Carburetor air filter (dry type)	50.00	T-6218	1920-27 Choke return spring for the Holley NH carburetor	1.30
T-6208	Carburetor adj. Clamp Nut, 1920-25 NH	3.50	T-6224	1920-27 Carburetor throttle & choke plate clip, Ford NH, Kingston L-4, Vaporizer.	.80 ea.
T-6208 B	Adjusting needle, clamping nut used only on 1926-27 NH carburetor	3.95	T-6256	1926-27 Vaporizer choke lever assembly	14.75
T-6209	1920-26 Carburetor throttle & choke plate, Ford NH	2.50 ea.	T-6257	1926-27 Vaporizer choke plate	1.95
T-6210	1920-26 Float lever pin, Ford, NH	.50 ea.	T-6259	1926-27 Vaporizer throttle lever & rod assembly	10.50
T-6210/12 GJ	Float valve and seat. Modern design with two ball seat for NH Holly carburetor	18.00	T-6260	1926-27 Vaporizer Throttle plate	2.25
T-6210/12	Original design float valve for NH Holly	14.50	T-6263 S	1926-27 Vaporizer air shaft assembly & screw set	5.00
T-6210/12 GL	Grose jet for Kingston L	22.00	T-6269	Vaporizer outlet tube, brass w/flange	3.50
T-6210/12 GL4	Grose jet for Kingston L-4	22.00	T-6271	Vaporizer outlet tube nut	3.95
T-6210/12 G	Grose jet for Holley G	20.00	T-6273	1926-27 Vaporizer plate	2.50
T-6210/12 GV	Grose jet Vaporizer	18.00	T-6276	Vaporizer air tube	4.75
T-6211	1917-22 NH Bowl Nut used in place of drain valve	10.70	T-6277	Vaporizer heating support	2.25
T-6212 S	1920-26 Ford NH viton seat needle & seat set	13.75	T-6278	1926-27 Vaporizer adjusting needle nut.	3.95
			T-6279	1926-27 Vaporizer adjusting needle assembly	13.00
			T-6283	1926-27 Vaporizer Adjusting needle seat	9.00
			T-6295 OR	1909-27 Original carburetor inlet elbow	4.25
			T-6295 RE	Replacement carburetor inlet elbow with compression fitting	2.75
			T-6299	1926-27 Vaporizer Control Rod	Disc.

Lights

* Official Licensed Product
Official Motor Vehicle Accessories

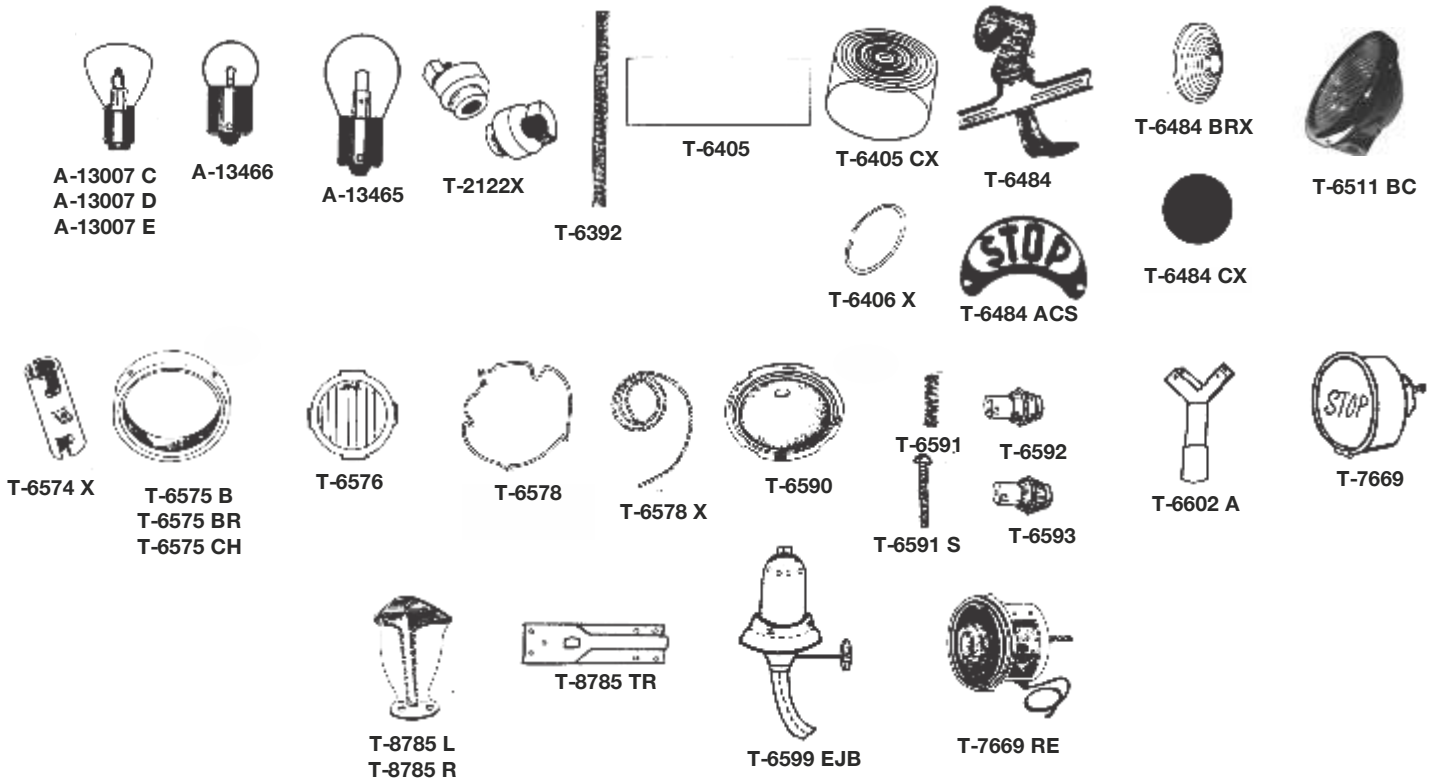

NUMBER	NAME OF PART	PRICE	NUMBER	NAME OF PART	PRICE
A-13007 C	6 volt 32-32 CP Headlight bulb	1.25 ea.	T-6602 A	1909-15 Gas headlight burner, standard	39.95
A-13007 D	6 volt 50-32 Headlight bulb	1.45 ea.	T-6602 B	1909-16 Alco gas headlight burner	Disc.
A-13007 E	12 volt headlight bulb	1.45 ea.	T-6957 C	1915-27 Clear Tail light lens	8.25
T-13007 M	Magneto headlight bulb 24V 50CP	3.75 ea.	T-6957 R	1915-27 Red Tail light lens	8.25
A-13465	6 volt Stoplight bulb	.95 ea.	T-7669	1909-16 Beautiful brass accessory stop light with dark red lens. Stop glows bright red when brake is applied	135.00
A-13466	6 volt Tail light bulb 3 cp	.85 ea.	T-7669 RE	1919-25 Original Style Electric Tail light Replacement, left side with license lens.	40.00
T-2122X	1909-25 Headlight loom bushing. Protects wire where it comes through hood shelf.	4.25 pr.	T-7669 RE2	1919-25 Original Style Electric Tail light Replacement, right side.	40.00
T-6392	1909-27 Oil lamp wick	.60 ea.	T-8785 L	1926-27 Tail light Bracket, left	13.95
T-6405	1919-25 Tag light lens for electric light	.50	T-8785 R	1926-27 Tail light Bracket, right	10.50
T-6405 CX	1926-27 Clear cup shape tail light lens	11.00	T-8785 TR	1925-27 Pickup tail light bracket. Mounts tail light to bed crossmember	59.00
T-6406 X	Wire Retainer, tail light	1.00	T-6574 Q	1909-16 Quartz brass light conversion kit. Adapter with 55 watt 12 volt bulb replaces gas burner.	105.00 pr.
T-6484	1926-27 Tail light, complete with bracket & lens	61.95 ea.	T-6599 EJB	1908-14 E & J bayonet base burner. E & J Detroit logo on wide adjusting knob. Comes with wick installed. Will not fit 1915-27 cowl lights.	150.00 ea.
T-6484 ACS	1926-27 Accessory tail light metal "stop" plate. Also fits "Dodge".	22.95	T-6600 KIT	Gas lamp hook up kit. 8' cooper tubing, 3' red rubber hose & 6 brass clamps.	51.95 kit
T-6484 BRX	1920-25 Electric Tail light lens	8.00	T-6600 CL	1909-14 Red gaslight hose clamps	5.00
T-6484 CX	1926-27 Celluloid lens for tail light	1.35 ea.	T-6600 T	1909-19 Red rubber tubing for headlights.	6.50 ft.
T-6511 BC	1926-27 Headlights black with chrome rim.	325.00 pr.	T-6958 8	1915 Brass kerosene E & J cowl light chimney top.	65.00
T-6574 X	1915-27 Headlight socket, double contact	13.00	T-6958 9	1915 Brass kerosene E & J tail light chimney top.	65.00
T-6574 SGL	1915-27 Headlight socket, single contact	13.50			
T-6575 B	1915-27 Headlight rim, Black	21.75 ea.			
*T-6575 BR	1915-27 Headlight Rim, Brass	24.95			
*T-6575 CH	1926-27 Headlight Rim, Chrome	32.00			
*T-6576	1915-27 Script headlight lens	17.50			
T-6578	1915-27 Headlight retaining wire	4.00			
T-6578 X	1915-27 Headlight lens gasket	1.50 pr.			
T-6590	1915-27 Headlight reflectors	34.00 ea.			
T-6591	1915-27 Headlight focus spring	.40 ea.			
T-6591 S	1915-27 Headlight focus screw	.40 ea.			
T-6592	1915-27 Double contact headlamp plug	9.00 ea.			
T-6593	1915-27 Single contact headlight and tail light plug	9.00 ea.			

Windshield Parts

* Official Licensed Product
Windshield Components



A-351000



A-37154R

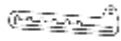

A-45463SS



T-7801



T-7801 BL



T-7802



T-7818/19 B



T-7824 C



T-7824 D



T-7831



T-7839



T-7840 15-22



T-7840 23-25



T-7840 26-27



T-7840 H



T-7840 OH



T-7837 CH



T-45410

NUMBER	NAME OF PART	PRICE
T-7818/19 B	Model T Brass Windshield Hinges	69.00 pr.
T-7824 C	1923-25 Steel windshield glass clamp	4.00
T-7824 D	1926-27 Steel windshield glass clamp	4.00
T-7831	Side curtain hooks	.50 ea.
T-7836	1915-25 Cushion rubber between w/s frame & cowl on open cars. Identical to original	2.95
T-7839	Windshield filler block -- must be drilled & tapped for screws.	2.00 per ft.
T-7840 15-22	1915-22 Open car windshield gasket set	5.50
T-7840 23-25	1923-25 Open car windshield gasket set	7.00
T-7840 26-27	1926-27 Open car windshield gasket set	6.80
T-7840 H	1922-27 Open car windshield H. rubber	3.25
T-7837 PS	1926-27 Stamped steel stanchions plain	175.00
T-7840 OH	1915-22 Open car windshield H. rubber	3.00
T-7837	Rubber windshield post (sold by foot)	1.00
T-7837 CH	1926-27 Open car, windshield stanchions, chrome	235.00
T-45410	1926-27 Model T closed car aluminum windshield frame	360.00

NUMBER	NAME OF PART	PRICE
A-351000	1923-27 Chrome plated windshield wing nut	2.75
A-37154 R	Windshield frame cone	5.45
A-45463 SS	1925-31 Closed car windshield swing arms. Satin finished stainless steel with positive stops every 3/4".	26.00
T-7801	1909-27 Windshield hand wiper (complete)	26.50
T-7801 BL	1909-27 Wiper blade only	4.60
T-7802	Windshield wiper clamp, clamps hand wiper to frame	6.50
B-37158	1922-36 Windshield post stud set, 4 pcs	5.50

Windshield Frames

(Open Cars)

Windshields listed below do not have glass clamps, glass channel or filler blocks. Includes upper & lower frames.

NUMBER	NAME OF PART	PRICE
T-7820	1913-14 Roadster & Touring	270.00
T-7827	1915-16 Roadster & Touring	270.00
T-7828	1917-22 Roadster & Touring	270.00
T-7829	1923-25 Roadster & Touring	270.00
T-7830	1926-27 Roadster & Touring	385.00

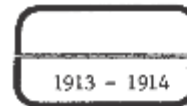

T-7820

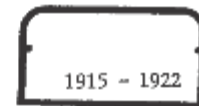

T-7827
T-7828

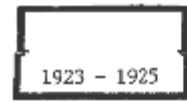

T-7829

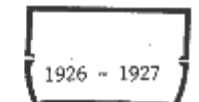

T-7830

Mirrors



T-7853 HVB
T-7853 HVC



T-7853 XB T-18257 X

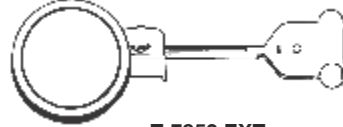

T-7853 EXT



T-17704 A

NUMBER	NAME OF PART	PRICE
T-7853 EXT	1909-15 Black powder coated rear view mirror. Attaches to stanchion. Can be extended 2 3/4" to see around open car top in down position.	60.00
T-7853 HVB	1909-15 Solid brass rear view mirror, Fits on windshield stanchion.	45.00
T-7853 HVC	1916-27 Solid brass chrome plated rear view mirror. Fits on windshield stanchion.	41.00
T-7853 X	1916-27 Open car rear view mirror. Duplicate of original. Fits inside, centered on the upper windshield frame.	31.50
T-7853 XB	1909-27 Open car brass inside rear view mirror	26.50
T-7853 SS	1909-27 Open car stainless steel inside rear view mirror	29.00

NUMBER	NAME OF PART	PRICE
T-17704	2 X 5 Mirror glass	6.00
T-18257 X	1909-27 Closed car rear view mirror. Fits inside, centered, just above the windshield.	19.75



Seat Springs

Seat springs are identical to original and are painted black. Please allow 3 weeks for delivery.

COUPE			1909-12		
1915-23				Did not have backrest springs, backrest was only covered padding.	
TS-7000	Front Cushion	175.00	1909-12		
TS-7001	Front Backrest	126.00	TS-7023	Front Cushion	168.00
1924-25			TS-7024	Rear Cushion	170.00
TS-7002	Driver Cushion	67.00	1913		
TS-7002	Passenger Cushion	67.00	TS-7025	Front Cushion	151.00
TS-7004	Front Backrest	126.00	TS-7026	Rear Cushion	172.00
1926-27			1914-15		
TS-7005	Front Cushion	183.00	TS-7027	Front Cushion	149.00
TS-7006	Front Backrest	126.00	TS-7028	Front Backrest	88.00
			TS-7030	Rear Backrest	72.00
			TS-7029	Rear Cushion	167.00
			1916-21		
			TS-7031	Front Cushion	145.00
			TS-7032	Front Backrest	149.00
			TS-7033	Rear Cushion	167.00
			TS-7034	Rear Backrest	119.00
			1922-25		
			TS-7035	Front Cushion	119.25
			TS-7036	Front Backrest	81.75
			TS-7037	Rear Cushion	153.00
			TS-7038	Rear Backrest	94.00
			1926-27		
			TS-7039	Front Cushion	122.00
			TS-7040	Front Backrest	89.00
			TS-7041	Rear Cushion	127.25
			TS-7042	Rear Backrest	111.00
TUDOR			ROADSTER & TOURING		
1923-25			1909-12	Bodies vary. Please send measurements and pattern from your car.	
TS-7011	Driver Front Cushion	204.00			
TS-7012	Passenger Front Cushion	102.00			
TS-7012 A	Driver Front Backrest	76.25			
TS-7013	Rear Cushion	166.00			
TS-7014	Rear Backrest	149.00			
1926-27					
TS-7015	Driver Front Cushion	82.00			
TS-7016	Passenger Front Cushion	102.00			
TS-7017	Driver Front Backrest	64.00			
TS-7018	Rear Cushion	167.00			
TS-7019	Rear Backrest	149.00			

Interior Trim Screw Sets

NUMBER	NAME OF PART	PRICE	NUMBER	NAME OF PART	PRICE
#21	1917-22 Roadster and Touring	6.50	#54	1923-25 Fordor	19.00
#22	1919-22 Coupe	13.00	#71	1926-27 Roadster and Touring	3.00
#23	1917-22 Center door	15.00	#72	1926-27 Coupe	13.00
#51	1923-25 Roadster and Touring	2.95	#73	1926-27 Tudor sedan	6.50
#52	1923-25 Coupe	13.00	#74	1926-27 Fordor sedan	21.00

Top Kits

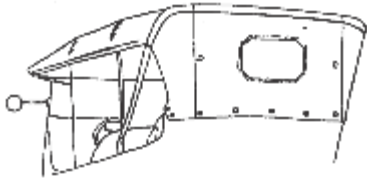

Top kits are precut and sewn with finished quarters sewn on. Kits come ready to be fitted to your top bows. Bow pads and wrappers are included in the rear panel. Specify Colonial Grain or Cobra Short Grain material. Please allow 10-12 weeks for delivery. A 30% down payment is required with balance due before shipping. Pricing as of March 2006—subject to change without notice, but not altered once order is placed.

NUMBER	NAME OF PART	PRICE
TK-1113	1911-12 Roadster	Disc.
TK-1114	1911-12 Touring	490.00
TK-1115	1913-14 Roadster	Disc.
TK-1116	1913-14 Touring	450.00
TK-1117	1915 Roadster	340.00
TK-1118	1915 Touring	425.00
TK-1119	1916 Roadster	340.00
TK-1120	1916 Touring	425.00
TK-1121	1917-22 Roadster, specify year	340.00
TK-1122	1917-22 Touring	425.00
TK-1123	1923-24 Roadster	340.00
TK-1124	1923-24 Touring	425.00
TK-1125	1925 Roadster	340.00
TK-1126	1925 Touring	425.00
TK-1127	1926-27 Roadster	340.00
TK-1128	1926-27 Touring	425.00

Upholstery Kits



Seat kits are made of old original patterns in black vinyl. Cardboard kick panels for sides and doors are included. All new fasteners and fabric trim is included. Please allow 10-12 weeks for delivery. A 30% down payment is required with balance due before shipping. Pricing as of March 2006—subject to change without notice, but not altered once order is placed.

NUMBER	NAME OF PART	PRICE
TU-1116	1913-14 Touring	840.00
TU-1117	1915 Roadster	440.00
TU-1118	1915 Touring	830.00
TU-1119	1916-22 Roadster	400.00
TU-1120	1916-22 Touring	600.00
TU-1121	1923-25 Roadster	360.00
TU-1123	1923-25 Touring	600.00
TU-1124	1926-27 Roadster	440.00
TU-1125	1926-27 Touring	680.00
TU-1126	1926-27 Coupe	920.00
TU-1127	1923-25 Tudor	1,200.00
TU-1128	1926-27 Tudor	1,360.00
TU-1129	1917-22 Center Door Sedan	1,500.00
TU-1130	1923-25 Fordor sedan	1,400.00
TU-1131	1926-27 Fordor sedan	1,400.00

Top Boots

Top boots are made of colonial grain material or short cobra grain. Used to secure top & keep it protected while in down position. Fasteners not included. Specify year & material when ordering.

NUMBER	NAME OF PART	PRICE
TB 11-27		216.00

Fasteners



T-7980 BF
T-7980 NF



T-7980 BSGL
T-7980 NSGL
T-7980 BDBL
T-7980 NDBL



T-7970 BDSL
T-7970 NDSL

NUMBER	NAME OF PART	PRICE
T-7980 BF	Brass female common sense fastener. Used on tops & side curtains	.35
T-7980 NF	Nickel plated female common sense fastener. Used on tops & side curtains	.30
T-7980 BSGL	Brass male common sense fastener. Used on tops & side curtains	.90
T-7980 NSGL	Nickel plated male common sense fastener. Used on tops & side curtains	.75
T-7980 BDBL	Brass common sense fastener. Used for two layers of common sense fasteners	1.00
T-7980 NDBL	Nickel plated common sense fastener. Used for two layers of female common sense fasteners	1.00
T-7980 TK	Upholstery panel tacks 3/8" head 5/8" long, button head	2.00
T-7970 BDSL	Brass twist lock fastener single thickness	.85 ea.
T-7970 NDSL	Nickel twist lock fastener single thickness	.85 ea.
T-7950 LAD	Brass nickel plated Lift-a-Dot fastener, 2 pcs	.75

Side Curtains



NUMBER	NAME OF PART	PRICE
TC-1114 R	1914 Roadster Side Curtains	Disc.
TC-1114 T	1914 Touring Side Curtains	435.00
TC-1115	1915-16 Model T Touring Side Curtains	435.00
TC-1116	1915-16 Roadster Side Curtains	325.00
TC-1117	1917-22 Roadster Side Curtains	325.00
TC-1122	1917-22 Touring Side Curtains	410.00
TC-1123	1923-25 Roadster Side Curtains	300.00
TC-1124	1923-25 Touring Side Curtains	410.00
TC-1127	1926-27 Roadster Side Curtains	300.00
TC-1128	1926-27 Touring Side Curtains	460.00

Car Cover

NUMBER	NAME OF PART	PRICE
T-789678 T	1909-25 Touring car, spun-bonded polypropylene, breathable, water repellent (NOT water proof), UV treated, soft abrasion-resistant material.	100.00

Back of Front Seat



This is the panel that the back rest spring fastens to. Completely formed with all beads and bends. Small amount of fitting may be required as early Ford bodies made by different manufacturers were slightly different in some places.

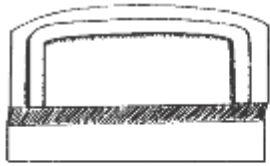

S-100

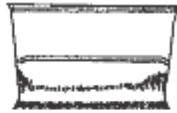

S-104



S-105



S-109

NUMBER	NAME OF PART	PRICE
S-100	1926-27 Roadster	190.00
S-101	1913-14 Touring	135.00
S-102	1915-21 Touring	145.00
S-103	1922-25 Touring	145.00
S-104	1913-14 Roadster	140.00
S-104 A	1915-22 Roadster	140.00
S-105	1923-24 Roadster	140.00
S-109	1926-27 Touring	260.00

Rear Center of Body Panel



S-108

NUMBER	NAME OF PART	PRICE
S-106	1926-27 Touring	150.00
S-106 A	1926-27 Tudor Sedan	150.00
S-107	1913-21 Touring	75.00
S-108	1922-24 Touring	150.00
S-108 A	1925 Touring 90 Top Edge	150.00
S-110	1926-27 Coupe Below Trunk Lid	55.00
S-111	1926-27 Roadster Below Trunk Lid	55.00
S-112	1924-25 Coupe Below Trunk Lid	50.00

Front Seat Heel Panel

This is the panel that is directly behind your heel if you are sitting in the seat. Formed of 20ga. steel with all beads in correct location.



S-114

NUMBER	NAME OF PART	PRICE
S-113	1913-14 Touring & Roadster	42.00
S-114	1915-21 Touring & Roadster	55.00
S-115	1922-25 Touring & Roadster	60.00
S-116	1926-27 Touring & Roadster	43.00

Rear Seat Heel Panel



S-120

NUMBER	NAME OF PART	PRICE
S-118	1913-14 Touring	43.00
S-119	1915-21 Touring	60.00
S-120	1922-25 Touring	60.00
S-121	1926-27 Touring	60.00
S-121 A	1926-27 Tudor Touring	60.00

Front Seat Frame

This part includes the heel panels with side strips or panels and floor pans on some models. Also rear panels or toe panels on some models. Seat spring sits on this part. Duplicate of original.



S-127 A



S-127 R

NUMBER	NAME OF PART	PRICE
S-122	1915-21 Roadster	115.00
S-123	1922-25 Roadster	110.00
S-125	1915-21 Touring	140.00
S-126	1922-25 Touring	140.00
S-127	1926-27 Roadster (with rear riser)	140.00
S-127 A	1926-27 Touring	85.00
S-127 C	1926-27 Coupe	75.00
S-127 R	1926-27 Roadster (riser only)	50.00

Rear Seat Frame



S-128



S-130

NUMBER	NAME OF PART	PRICE
S-128	1915-21 Touring	235.00
S-129	1922-25 Touring	235.00
S-130	1926-27 Touring	235.00
S-131	1926-27 2-Dr. Sedan	210.00

Rear Seat Toe Panel



Your toe rests on this part when sitting in rear of touring. These are exact duplicates of originals.

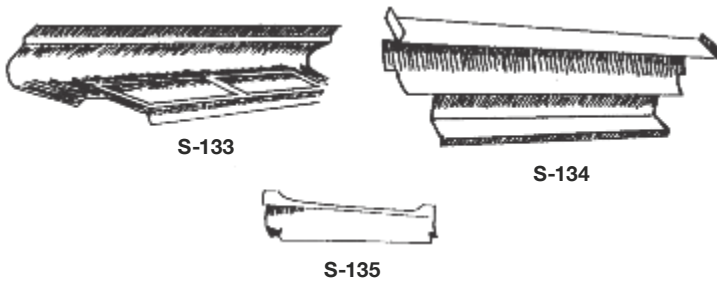

NUMBER	NAME OF PART	PRICE
S-132	1913-14 Touring	55.00
S-133	1915-21 Touring	60.00
S-134	1922-25 Touring	60.00
S-135	1926-27 Touring	85.00

Seat Frame Lid

This metal 20ga. lid is duplicate of original. All beads & holes. Sorry no hinges.



NUMBER	NAME OF PART	PRICE
S-136	1915-20 Front Seat Touring & Roadster	90.00
S-137	1915-20 Rear Seat Touring & Roadster	90.00

Door Patch Panels

NUMBER	NAME OF PART	PRICE
S-307 C	1923-25 Coupe outer door patch	65.00 pr.
S-307 E	1926-27 Tudor & Coupe over door patch panels 7" high	72.00 pr.
S-307 ESL	1926-27 Tudor & Coupe door skin. Bottom up belt line. Left	105.00 ea.
S-307 ESR	1926-27 Tudor & Coupe door skin bottom up to beltline. Right	105.00 ea.
S-307 F	1926-27 Coupe & Tudor inner door bottom	48.00 pr.
S-307 T	1923-25 Truck TT Lower 7" outer door skin patch	66.00 pr.

Pan Under Front Seat Frame

Pans have X bead 1927 have off-set edge.

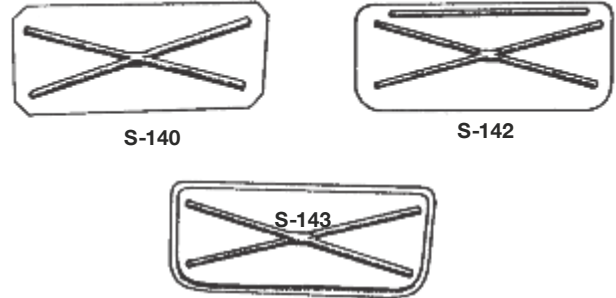

NUMBER	NAME OF PART	PRICE
S-140	1926 Touring & Roadster	50.00
S-141	1927 Touring & Roadster	55.00
S-142	1926 Coupe	50.00
S-143	1927 Coupe	55.00
S-144 RS	1926-27 Coupe (Rear Sub Frame Below Rear Panel)	66.00

Trunk Floor

Complete panel inside trunk area. All holes and beads, perfect fit. (Note roadster floor is sent freight collect.)

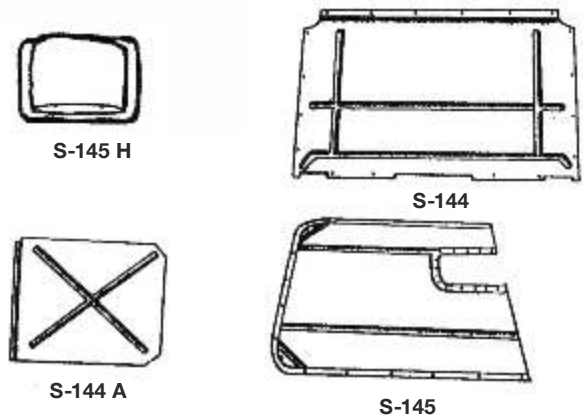

NUMBER	NAME OF PART	PRICE
S-144	1926-27 Coupe w/o hump	85.00
S-144 A	1926-27 Coupe (panel opposite battery)	25.00
S-144 H	1926-27 Center hump for coupe trunk floor	36.00
S-145	1926-27 Roadster (has battery cut out no center hump)	270.00
S-145 C	1923-25 Coupe Trunk floor	355.00
S-145 H	1926-27 Center hump for roadster trunk floor	42.00

Door Sills



This is part of outer body just under door on Touring & Roadster.



S-146

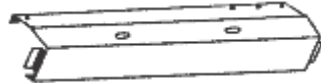

S-146 A



S-146 B

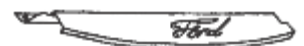

S-146 C



S-146 D



S-146 SP



S-146 SPT



S-146 SPR



S-148

NUMBER	NAME OF PART	PRICE	NUMBER	NAME OF PART	PRICE
*S-146	1926-27 Touring & Roadster Script 1 pc. Rocker & Sill , steel	75.00 pr.	*S-146 SP	1926-27 Touring & Roadster Aluminum Front Script	80.00 pr.
S-146 A	1926 Touring & Roadster plain rocker panel Goes under S-146 SP.	54.00 pr.	*S-146 SPR	1926-27 Touring & Roadster Plain rear, Steel	60.00 pr.
*S-146 B	1926-27 Coupe & Tudor, 1923-25 Tudor 28 1/4"	72.00 pr.	S-146 SPT	1926-27 Touring, Rear, Aluminum Plain	78.00 pr.
*S-146 C	1923-25 Coupe sill plate 23 1/2"	72.00 pr.	S-146 SR	1923-25 Sedan rocker panel fits under S-146 B	115.00 pr.
*S-146 CR	1923-25 Coupe rocker panel fits under S-146 C	114.00 pr.	S-147	1915-26 Touring & roadster front sill plates	Disc.
S-146 CD	1921-25 Center door sill plates	78.00 pr.	S-148	1915-25 Touring rear, Rocker Panel under door	78.00 pr.
*S-146 D	1926-27 Fordor	144.00 pr.	S-177	1919-25 Touring rear step plate. Covers inside sill under rear doors	36.00 pr.
			S-146 SPTS	1926-27 Touring Rear Aluminum Script	90.00 pr.

Deck Lid

Completely formed 20ga. with diamond and keyhole. Inner is duplicate of original. Ready for installation. All blind nuts for hinges & catch installed. Does not come with hinges or latch. (Hundreds of satisfied customers).



S-161



T-9485 L



T-9485 H



T-9484 B



S-159

NUMBER	NAME OF PART	PRICE	NUMBER	NAME OF PART	PRICE
S-159	1926-27 Roadster (rain gutter) fits under top edge of deck lid, 1 pc.	24.00	T-9484 B	1926-27 Deck Lid Key	7.00
S-160	1926-27 Roadster Skin Only	186.00	T-9485 L	1926-27 Deck Lid Latch	22.00
S-160 C	1926-27 Coupe deck lid skin	186.00	T-9485 H	1926-27 Deck Lid Hinge, roadster	25.50 pr.
S-161	1926-27 Steel Deck Lid, Roadster only	520.00	T-9487 A	1926-27 Coupe Trunk Lid Support	48.00
			T-9487 B	1926-27 Roadster Trunk Lid Support	50.00

Body & Patch Panels

* Original Licensed Products
Specialty Metal Products

Lower 5"-6" of body (normally rusted out)



S-149 L



S-149 R



S-150 A



S-150 L



S-150 R



S-152



S-152 A



S-153



S-154



S-155



S-156



S-157



S-158



ST-875

NUMBER	NAME OF PART	PRICE	NUMBER	NAME OF PART	PRICE
S-149 L	1915-22 Roadster quarter, back of left door forward	162.00	S-153	1913-22 Touring (rear corners 6")	42.00 pr.
S-149 R	1915-22 Roadster quarter, back of right door forward	162.00	S-154	1926-27 Roadster Rear Quarter Panel Patch behind door 7" high	102.00 pr.
S-150 A	1915-25 Touring (lower 5") body side	90.00	S-154 B	1926-27 Tudor Sedan rear quarter patch.	55.00 pr.
S-150 L	1915-25 (state high or low cowl.) Touring (complete body side with fake door)	235.00	S-154 C	1926-27 Coupe Rear Quarter Patch Panel	55.00 pr.
S-150 R	1915-25 (state high or low cowl.) Right side complete with door opening.	295.00	S-155	1926-27 Roadster PU rear quarter panel.	102.00 pr.
S-152	1915-22 Touring (rear quarter complete panel)	175.00 pr.	S-156	1926-27 Cowl patch panels. 6" high	55.00 pr.
S-152 A	1915-22 Touring (lower 5") quarter	20.00 pr.	S-156 C	1926-27 Cowl patch (Coupe).	55.00 pr.
			S-157	1926-27 Touring patch between doors.	60.00 pr.
			S-158	1926-27 Inner fender patch (Coupe & Sedan).	55.00 pr.
			ST-875	1926-27 T-strip for each side sedan rear panel.	54.00 ea.

Pickup Box Ft. Panel

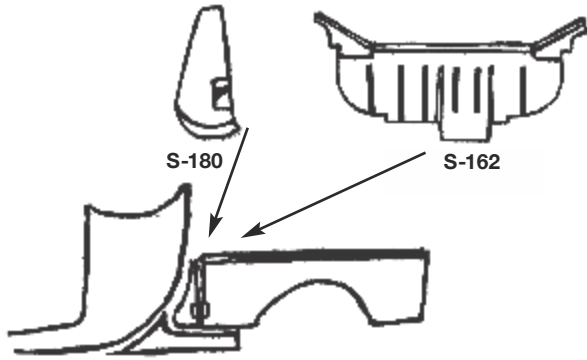

Just like Henry made with battery cut out. Die stamped brackets 16 gauge. Cold roll steel.

NUMBER	NAME OF PART	PRICE
S-162	1926-27 Pickup bed front panel	140.00
S-180	1926-27 Pickup bed filler pan (between body & box)	55.00

Front Floor Board Supports

These support the upper floor. Boards fit all Touring & Roadster.



NUMBER	NAME OF PART	PRICE
S-176	1922-25 Touring & Roadster	42.00

Sill Covers (Turtle Deck)

NUMBER	NAME OF PART	PRICE
S-165	1923-25 Roadster sill covers under turtle deck 3 pc.	60.00
S-165 A	1915-22 Roadster sill covers under turtle deck (2 pc - no bead)	48.00

Dash

NUMBER	NAME OF PART	PRICE
S-170	1923-25 original style with holes	85.00
S-170 SR	1923-25 Street rod style without holes	85.00

Fenders

We are now carrying Model T Fenders manufactured by Rootlieb. These fenders will be shipped from California with freight from California paid by the buyer. Due to limited space we are only listing the most popular years. Please call for pricing on other years.

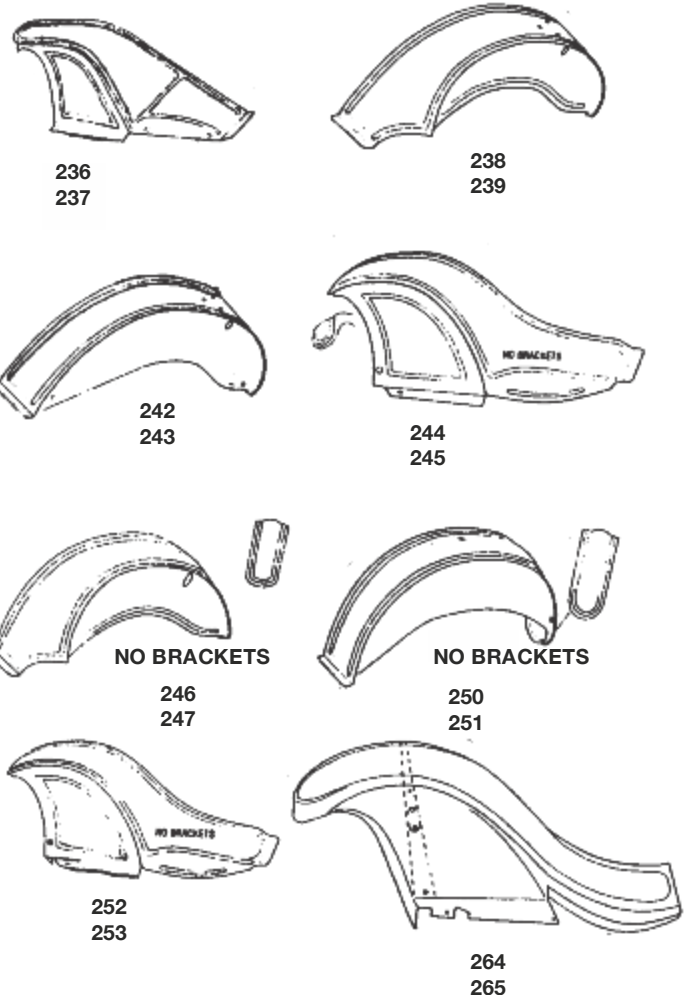

NUMBER	NAME OF PART	PRICE
236	1915-16 R.F. Fender	330.00
237	1915-16 L.F. Fender	330.00
238	1915-16 R.R. Touring & Rdstr. rear fender	330.00
239	1915-16 L.R. Roadster & Touring rear fender	330.00
242	1915-16 R.R. Hack Fender	330.00
243	1915-16 L.R. Hack Fender	330.00
244	1917-23 R.F. Passenger Fender	470.00
244 R	1917-25 Fender bracket rivet kit, 10 pc.	2.75
245	1917-23 L.F. Passenger Fender	470.00
246	1917-25 R.R. Touring & Roadster	360.00
247	1917-25 L.R. Touring & Roadster	360.00
250	1917-25 R.R. Hack Fender	360.00
251	1917-25 L.R. Hack Fender	360.00
252	1924-25 R.F. Passenger Fender	470.00
253	1924-25 L.F. Passenger Fender	470.00
254	1924-25 R.R. Coupe Fender	440.00
255	1924-25 L.R. Coupe Fender	440.00
264	1926-27 R.F. Fender	525.00
265	1926-27 L.F. Fender	525.00

Speedometer

*

Official Licensed Product
Official Motor Vehicle Accessories



T-17260 SG

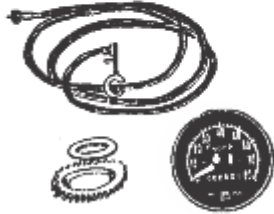

T-18000



T-18000 B

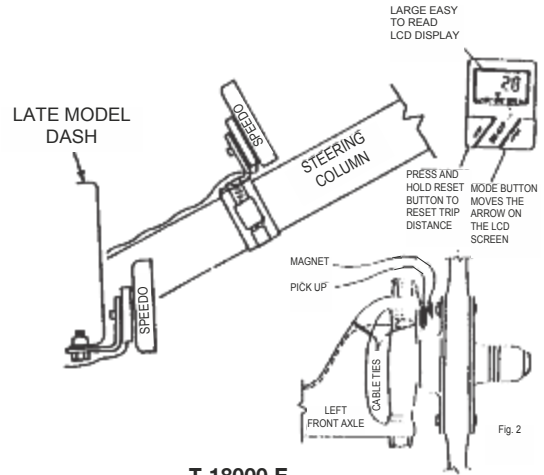

T-18000 E

NUMBER	NAME OF PART	PRICE	NUMBER	NAME OF PART	PRICE
T-17260 SG	SW fibre speedometer gear. 16 tooth, 8 pitch	18.00	T-17260 SGF	Speedometer, NOS Ford swivel gear with rectangular mounting hole. 12 tooth, 8 pitch	20.00
T-18000	1909-27 Speedometer assembly. Complete with everything needed to install in the car. Complete with instructions to mount unit	350.00	T-18000 E	1909-27 Digital Speedometer - Easy to install, accurate and easy to read. Large easy to read LCD display. Press and hold reset button to reset the trip distance. Mode button moves the arrow on the LCD screen.	Disc.
T-18000 B	1909-27 Speedometer steering column mounting bracket for T-18000. Eliminates cutting a hole in dash panel.	51.00			
T-17260 J	1909-19 Polished brass speedometer cable housing for Jones speedometer. No cable.	90.00			
T-17260 S	Same as above for SW speedometer.	90.00			

Floor Mats

Duplicate of original. Mats are for open cars.

NUMBER	NAME OF PART	PRICE
*T-7299 A	1909-14 Front mat	33.00
*T-7299 B	1915-25 Front mat	38.00
*T-7299 D	1915-25 Rear mat	28.00
*T-7299 C	1926-27 Front mat	34.00
*T-7299 E	1926-27 Rear mat	31.00

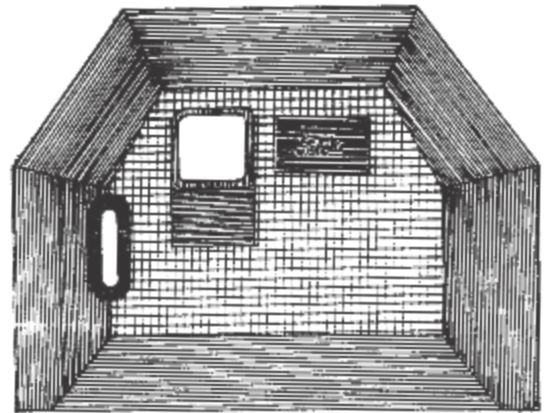

T-7299 B

T SPEEDSTER KIT

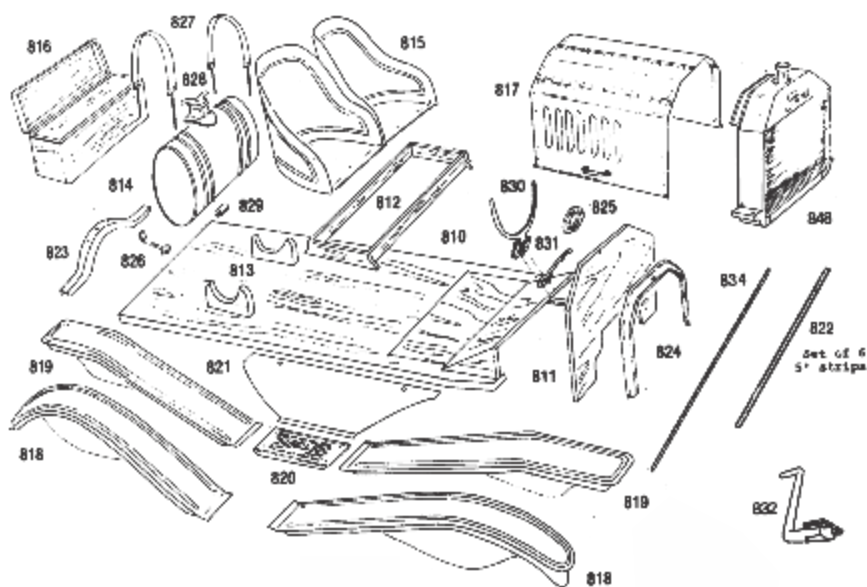
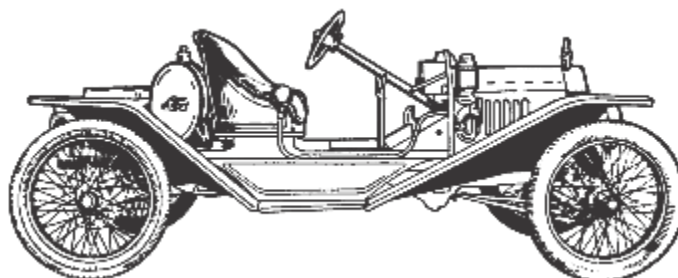

A SPEEDSTER OF CLASSIC DESIGN AND ELEGANCE! A speedster that will provide you with hours of enjoyment as well as being an excellent investment.

The T speedster is easy to assemble, even for a beginner. You will need to provide your own chassis and running gear. The kit is designed to fit perfectly on any 1909 to 1925 chassis. Your own creativity will add the distinctive finishing touches. Crated and shipped by truck.

NO. 800	Complete T Speedster Kit (Includes #s 810-837)	5265.00	NO. 823	Rear crossmember	65.00
NO. 805	Body Kit only (Includes #s 810 through 816)	1,710.00	NO. 824	Hood former	175.00
NO. 810	Floorboard and risers	650.00	NO. 825	Steering column wedge	25.00
NO. 811	Firewall	90.00	NO. 826	Tail light bracket	65.00
NO. 812	Seat Riser	155.00	NO. 827	Brass tank straps (Pair)	75.00
NO. 813	Tank Blocks (Pair)	70.00	NO. 828	Brass filler neck	200.00
NO. 814	Gas Tank	225.00	NO. 829	Brass lower gas outlet	15.00
NO. 815	Seat skins with wooden base & moulding	260.00	NO. 830	Brass windshield monacle (Cast, unpolished)	250.00
NO. 816	Tool Box (No hardware)	260.00	NO. 831	Steering column bracket	75.00
NO. 817	Hood	345.00	NO. 832	Rear fender bracket	40.00
NO. 818	Curved fenders (Set of 4)	1,400.00	NO. 833	Wooden hood shelves	70.00
NO. 819	Straight fenders (Set of 4)	1,400.00	NO. 834	Brass moulding for dash	100.00
NO. 820	Running board (Pair)	135.00	NO. 835	Aluminum moulding for seats	50.00
NO. 821	Splash aprons (Pair)	150.00	NO. 837	Dropped axle	235.00
NO. 822	Brass floor molding	85.00			

Speedster Accessories

* Official Licensed Product
Speedster Accessories

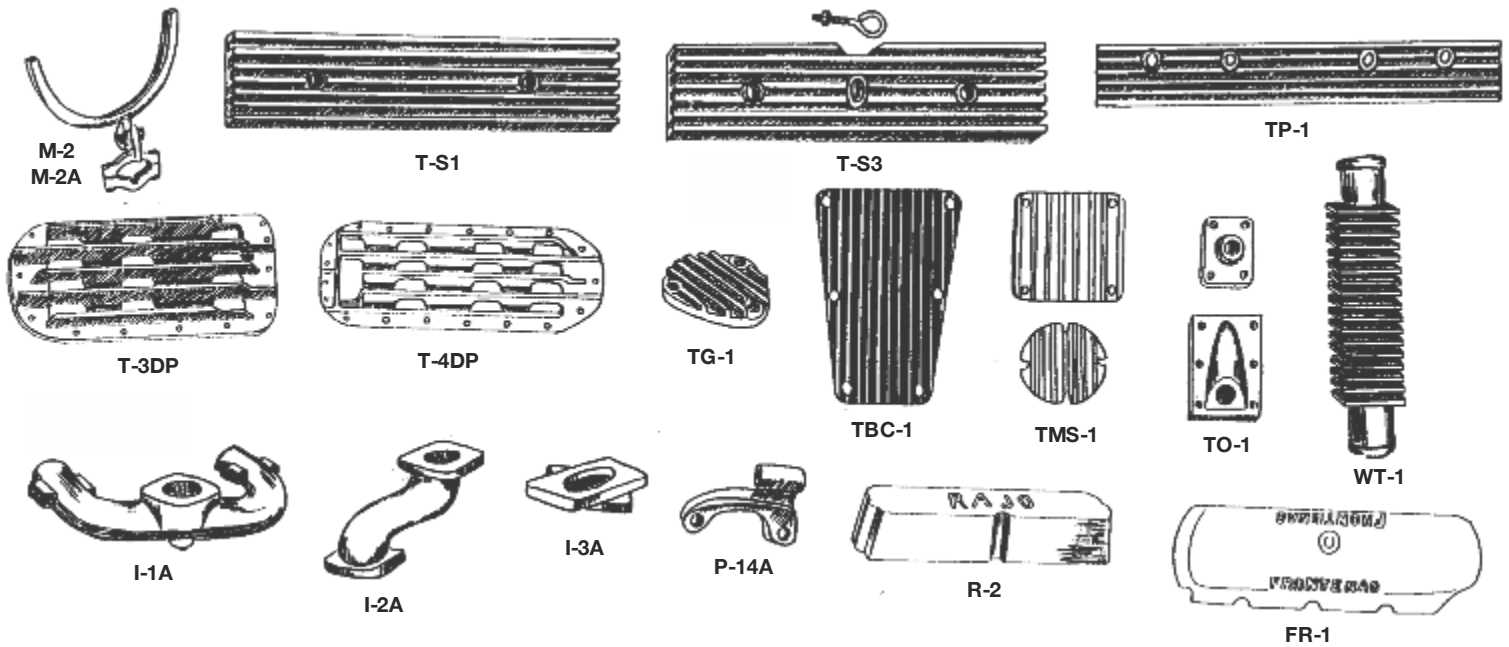

ALL CASTINGS ARE UNPOLISHED ALUMINUM, MADE IN USA

NUMBER	NAME OF PART	PRICE	NUMBER	NAME OF PART	PRICE
M-2	1909-27 15" Monocle windshield frame w/bracket, no glass, aluminum	83.00	WT-1	1909-27 Lower water tube, finned. Replaces metal tube	56.00
M-2A	1909-27 15" Monocle windshield frame w/bracket, no glass, brass, unpolished	150.00	T-GWO-1	Gas, water, and oil cans mount to runningboard or luggage rack. Unsoldered for display only	300.00
T-S1	1912-27 Valve cover, finned, replaces "T" metal cover	29.95	I-1A	1909-27 Universal intake manifold, can be used with most 1 1/4" updraft carburetors and many down draft. Including V8 (not drilled for carburetor pipe)	65.95
T-S3	1911-27 Left side cylinder cover w/eye bolt	31.50	TRL-1	1909-27 Throttle linkage, for above manifold	35.00
TP-1	1911-27 Port cover, finned, covers the ports when using overhead valves	29.00	I-2A	1909-27 Downpipe for updraft carburetor, "S" type use with I-1A manifold	31.00
T-3DP	1911-23 3 dip oil pan, deeply finned. Fits all short blocks	65.00	I-3A	1909-27 V8 Adaptor, use w/I-1A if using V8 carburetor	29.50
T-4DP	1925-27 4 dip oil pan, deeply finned fits later long pan. Cover has extra metal at rear it can be altered for engine with "A" crank. No spacer is needed	69.00	SW-1	1909-27 Steering wedge, lowers steering gear bracket	8.95
TG-1	1918-27 Generator block off plate. Starter cars	16.00	SW-2	1909-27 Collar & wedge, lowers steering gear	24.00
TBC-1	1911-27 Transmission band cover. Replaces steel cover, finned	26.00	R-1	Rajo valve cover. Fits model B, C, & 35	83.00
TMS-1	1918-27 Starter block off plates, use no starters	23.00	R-2	Rajo side valve cover. Fits all models, 1 pc. Can be cut in half to make 2 pc. cover	46.00
TO-1	Outside oil line fittings, 1 for transmission cover, 1 for side of pan. Tapped for 1/2" or 3/8" tubing	29.00	FR-1	Frontenac valve cover	80.00
			T-GWO-2	Gas, water, and oil cans mount to runningboard or luggage rack. Soldered and tested for use on car	390.00

Books

* Official Licensed Product
Walter P. Reuther Foundation



A-1



A-2



A-3

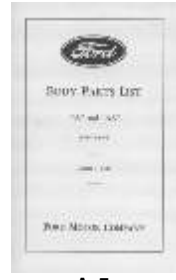

A-5



A-8



A-9



AT

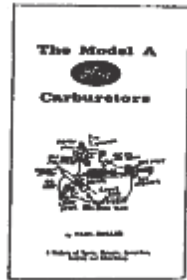

C-1



C-G



C-9

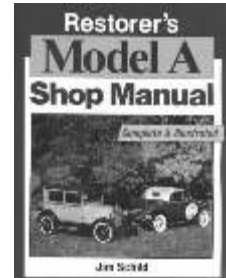

CM-9



P-1



P-2



P-6



P-7



P-13



PF-2

NUMBER	NAME OF PART	PRICE	NUMBER	NAME OF PART	PRICE
A-1	1928-31 Basic Model A information "Model A Restoration Manual"	13.75	C-9	Model "A" Album 143 pages, photographs illustrations & history of "A" and accessories	26.00
A-2	1928-32 Motor and Chassis Parts List	13.00	C-13	Tillotson Carburetor Repairing & Restoring	22.50
A-3	1928-31 MODEL A INSTRUCTION MANUAL. Reprint of the original owner manual that came with the Model A. Basic information of maintenance and simple repair.	13.00	C-23	Model A engine oil pump and distributor rebuild book, 110 detailed pages by McRae. Detailed and informative. Glossy pages and spiral bound.	19.50
A-3A	Late 1931 Model A Instruction Book - General guide to simple repairs and maintenance. New car manual.	13.00	CM-9	MODEL A SHOP MANUAL 200 page book with illustrations and practical "How To" information.	42.95
A-5	1928-31 BODY PARTS LIST	24.00	P-1	Model A Service Bulletins. Complete chronological change of Model A. 320 pages	35.00
A-8	Model "A" Passenger Car and Model "AA" Truck Engine-Chassis manual - 40 pages, 64 illustrations.	13.00	P-2	Gem From the River Rouge. Explains why the Model A was better than anything built before.	20.00
A-9	Building the 100 Mile Per Hour Model A, 32 pages	6.50	P-3	Indianapolis Service Letters	16.00
A-2 E	1928 Motor and chassis parts list (includes 28 AR parts)	14.00	P-6	MODEL A CONSTRUCTION OPERATION AND REPAIR. Hardback 500 page book	38.00
AT	Model A Truck Owner. Informative book on A & AA Trucks.	31.00	P-7	Legendary Model A Ford, social history of the Model A Ford, 1927-32. 304 pages 300 photos. Volume II.	Disc.
C-G	1928-31 Model A generator & starter restoration manual, also covers cutout & starter switch. 57 pages.	17.50	P-11	Hot Rod Ford	24.95
C-1	MODEL A CARBURETOR BOOK. Instructions for repair and operation.	13.50	P-12	Henry Ford, A Hearthside Perspective	35.00
C-8	Model A Carburetor book by Rex Reheis, long time builder. 48 pages on diagnosis, tools, assembly, etc.	26.00	P-13	Unauthorized Accessories	26.00
			PF-2	HARDWARE AND TRIM SUPPLY BOOK. Gives information on cars 1928-48. Pictures of many interior parts.	21.00

Books (continued)

* Official Licensed Product
Ward, Howell & Company, Inc.



C-16

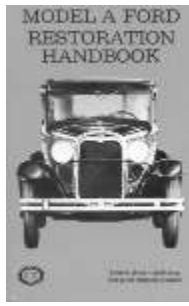

C-17

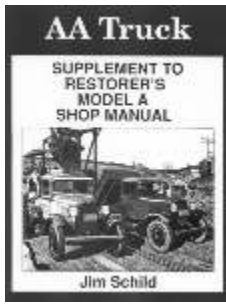

CM-10



CM-11



CM-18



E-2

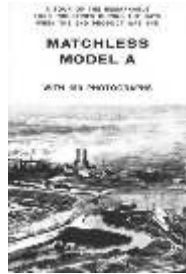

LAM



MAF-I - MAF-VIII



MAF-JS

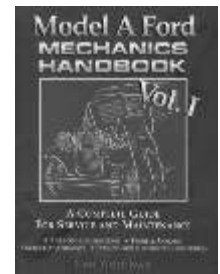

MAF-MH



MAF-MH II



MAF-PG



MAF-TS



MAM-1

NUMBER	NAME OF PART	PRICE	NUMBER	NAME OF PART	PRICE
C-16	How to Restore the Model A. Basic restoration information.	26.00	MAF-I	How to Restore Your Model A Volume 1	15.00
C-17	Model A Ford Restoration Handbook	26.00	MAF-II	How to Restore Your Model A Volume 2	15.00
CM-10	AA Truck Manual, a supplement to CM-9 Restorer's Model A Shop Manual by Jim Schild	23.50	MAF-III	How to Restore Your Model A Volume 3	15.00
CM-11	Selling the New Ford - A 178 page book written by Jim Schild containing many ads and literature written during the time of the Model A. Very interesting for the Model A owner and anyone interested in marketing and automobile history.	26.00	MAF-IV	How to Restore Your Model A Volume 4	15.00
CM-18	1930-31 Model A Coupe manual. Describes what each part looks like and how to fix & finish it. Has many picture diagrams and drawings. 175 pages.	31.50	MAF-V	How to Restore Your Model A Volume 5	15.00
E-2	Henry's Lady. A book filled with pictures about the Model A with over 320 fact filled pages. Extremely informative and detailed.	54.00	MAF-VI	How to Restore Your Model A Volume 6	15.00
HB-1	The Model A As Henry Built it. The book of authority, tells when various changes were made in the Model A as well as correct colors upholstery etc. A must for the serious restorer.	39.50	MAF-VII	How to Restore Your Model A Volume 7	15.00
LAM	Matchless Model A Tour of Ford Industries. Reprint of Ford book offering an overview of amazing methods which made motor car history.	16.00	MAF-VIII	How to Restore Your Model A Volume 8	15.00
			MAF-JS	Model A Judging Standards	36.00
			MAF-MH	A complete 400 page maintenance and repair manual for the Model A with 500 illustrations and 100 maintenance procedures.	36.00
			MAF-MH II	300 page book by Les Andrews, covers installation procedure of just about every accessory such as turn signals, hydraulic brakes, etc. Also shows installation procedures for body wood in coupes, tudors and pickups.	30.00
			MAF-PG	Paint & Finish Guide by Model A Ford Clubs with color chips	28.00
			MAF-TS	Troubleshooting & Diagnostics. Over 200 pages that include 100 diagnostic tests and troubleshooting aids, hundreds of symptoms-causes-and fixes, and complete theory of operation of every electrical and mechanical system. Includes hundreds of illustrations.	27.00
			MAM-1	Model A Miseries & Cures book	31.00

Books *(continued)*



MARC-I-X



MAR 1 & MAR 2



RMB



RMAP



ROA



SWR

NUMBER	NAME OF PART	PRICE	NUMBER	NAME OF PART	PRICE
MARC-I	Technically Speaking Volume 1, 120 page collection of articles published in the Model A News by the Model A Restorer's Club, years 1965 - 1967	12.50	MAR 1	Model A Restoration and Maintenance, Volume 1. Eleven chapters covers lubrication, starter, distributor, battery, carburetor, brakes, spindles and water pump, by Paul Mohler.	17.00
MARC-II	Technically Speaking Volume 2, 120 page collection of articles published in the Model A News by the Model A Restorer's Club, years 1968 - 1971	12.50	MAR 2	Model A Restoration and Maintenance, Volume 2. Nine chapters, 59 pages, covers ammeter, cutout, generator, carburetor, steering column and transmission, by Paul Mohler.	17.00
MARC-III	Technically Speaking Volume 3, 123 page collection of articles published in the Model A News by the Model A Restorer's Club, years 1972 - 1975	12.50	RMB	Model A Repaint Manual with paint chips and correct colors for each body style	28.00
MARC-IV	Technically Speaking Volume 4, 122 page collection of articles published in the Model A News by the Model A Restorer's Club, years 1976 - 1979	12.50	RMAP	Restoring the Model "A" Pickup	27.00
MARC-V	Technically Speaking Volume 5, 121 page collection of articles published in the Model A News by the Model A Restorer's Club, years 1980 - 1983	12.50	ROA	Restoring the Open A	27.00
MARC-VI	Technically Speaking Volume 6, 121 page collection of articles published in the Model A News by the Model A Restorer's Club, years 1984 - 1987	12.50	SWR	Steering Wheel Restoration Handbook. Step by step guide to restoring steering wheel.	11.00
MARC-VII	Technically Speaking Volume 7, 117 page collection of articles published in the Model A News by the Model A Restorer's Club, years 1988 - 1992	12.50			
MARC-VIII	Technically Speaking Volume 8, 112 page collection of articles published in the Model A News by the Model A Restorer's Club, years 1993 - 1996	12.50			
MARC-IX	Technically Speaking Volume 9, 119 page collection of articles published in the Model A News by the Model A Restorer's Club, years 1997 - 2000	12.50			
MARC-X	Technically Speaking Volume 10, 103 page collection of articles published in the Model A News by the Model A Restorer's Club, years 2000 - 2004	12.50			

Posters

NUMBER	NAME OF PART	PRICE	NUMBER	NAME OF PART	PRICE
POST I	Fabulous Ford Wall poster containing some 70 pictures of Fords from 1896 through 1940 showing various body styles	5.95	POST IV	Multi color poster of the most popular 1928-31 Fords. Great display for Ford enthusiast	7.00
POST II	Wall poster containing 40 pictures of Model A Fords	5.95	POST V	Wall poster containing pictures and part numbers of genuine Ford parts for the Model A	12.00
POST III	Wall poster containing a diagnostic chart (22" x 34") that allows the technical owner to locate engine problems by a systematic search	12.95	POST VI	Model T lubrication chart, shows lubrication points and frequency of lubrication	8.25
			POST VII	Model A lubrication chart, shows lubrication points and frequency of lubrication	8.25

Cast Iron Brake Drums



A-1125

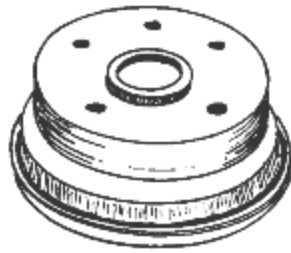

A-1126

A high quality USA manufactured cast iron brake drum. Machined on a fully computerized numerically controlled lathe. Excellent in quality appearance and performance.

NUMBER	NAME OF PART	PRICE
A-1125	Front	95.00 ea.
A-1126	Rear	95.00 ea.
A-1127	Brake drum reinforcing bands	125.00



WB-1015	Spoke Wheel Brush	4.95 ea.
---------	-------------------	----------

Wheels

Seals and Bearings

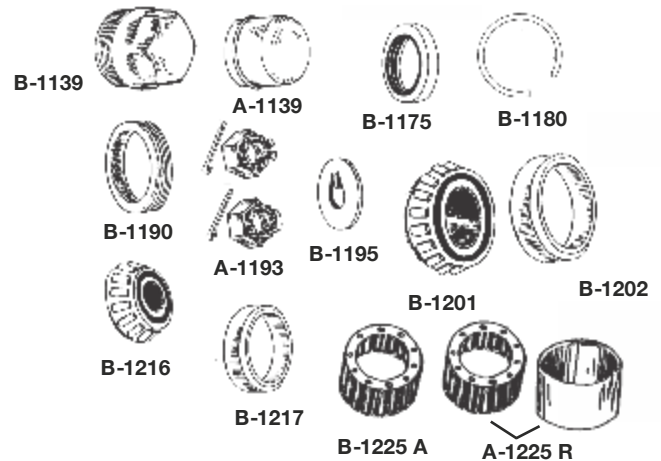
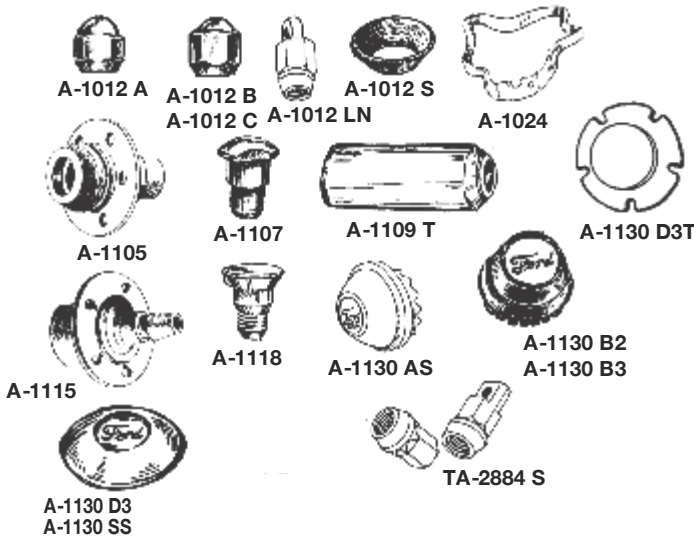

NUMBER	NAME OF PART	PRICE
A-1012 A	Short acorn lug cadmium plated (show car quality), 1928	2.20 ea.
A-1012 B	Acorn lug nuts cadmium plated	1.25 ea.
A-1012 C	Chrome plated lug nuts	1.10 ea.
A-1012 LN	1926-31 spare tire lug nut w/hole for lock	4.75 ea.
A-1012 S	Acorn nut shim for worn rim (5)	2.25 set
A-1012 SS	1925-31 Polished stainless steel lug nuts, manufactured to original specifications.	4.50 ea. 100.00 set
A-1024	Rim liner rubber	2.00 ea.
A-1105	1928-31 Model A Front Hub	160.00 ea.
A-1107	Front hub bolts	.80 ea.
A-1109 T	Used for installing A-1107 & A-1118. Must have hydraulic press used to spread shoulder of hub bolt	8.00 ea.
A-1115	1928-31 Model A Rear Hub	135.00 ea.
A-1118	Rear hub bolts	.90 ea.
*A-1130 AS	Early 28 Nickel plated steel hub cap	28.50 ea.
*A-1130 B2	1928-29 hub cap, stainless	10.50 ea.
A-1130 B3	1928-29 chrome plated steel hub cap. Close to original	13.00 ea.
*A-1130 D3	1930-31 Stainless hub cap with steel inner liner.	10.00 ea.
A-1130 D3T	Tool used to install 1930-31 s/s hub cap with steel liner	60.00

NUMBER	NAME OF PART	PRICE
*A-1130 SS	1930-31 stainless steel hub cap without inner liner. As original show car quality	14.00 ea.
A-17036	Hand crank/lug nut wrench	12.00
T-2884	1926-Early 28 Wire wheel lug nut set (23 pcs) Unpolished stainless steel	60.00
T-2884 SS	1926-Early 28 Wire wheel lug nut set (23 pcs) Polished stainless steel	110.00
B-1139	1931-35 Screw-in dust cap	5.50 ea.
A-1139	Drive-in dust cap	2.25 ea.
B-1175	1928-38 Rear grease seal	3.75 ea.
B-1180	1928-38 Rear wheel snap ring seal (same snap ring for bearings at each end of the transmission. Holds B-7025 & B-7065 in place.)	1.70 ea.
B-1190	1928-34 Front wheel seal	2.25 ea.
A-1193	Axle nut set (front)	3.00 pr.
B-1195	1928-54 Front hub grease retainer washer	1.15 ea.
B-1201	1928-48 Front wheel inner bearing USA	16.75 ea.
B-1202	1928-48 Front wheel inner race USA	10.00 ea.
B-1216	1928-48 Front wheel outer bearing USA	17.00 ea.
B-1217	1928-48 Front wheel outer race USA	7.80 ea.
B-1225 A	1928-36 Rear wheel bearing	28.50 ea.
A-1225 R	1928-31 Rear Hub repair race & bearing. Salvage pitted & worn hub by installing new race & new smaller bearing. Instructions included.	76.00 set

Spare Tire Parts



Made from quality leatherette. 1 pc. circle, no splices. Silk screened Ford emblem, not a patch. A draw string to make a nice fit on any tire. Super quality.



A-1395



A-18330

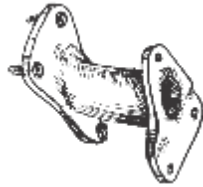

A-1379 B
A-1379 AR

NUMBER	NAME OF PART	PRICE
A-1379 AR	Spare tire carrier 1928-29 Coupe, Sport Coupe, Cabriolet and Roadster	70.00
A-1379 B	Spare tire carrier 1930-31 Coupe, Sport Coupe, Cabriolet and Roadster	70.00
A-1379 U	1928-31 Used rear spare tire mount, Phaeton and Sedan	50.00
*A-1395 A 1	21" black 1928-29	33.00
*A-1395 A 2	21" tan 1928-29	33.00
*A-1395 B 1	19" black 1930-31	33.00
*A-1395 B 2	19" tan 1930-31	33.00
A-1379 AMB	1928-31 Coupe, Sport Coupe, Cabriolet, and Roadster spare tire carrier mounting bolts	2.25
A-1379 BMB	1928-31 Tudor, Phaeton, and some Fordor rear spare tire carrier mounting bolts	2.00
A-18330	Spare tire lock	Disc.



1231



A-1400 B16
A-1400 B25
A-1401 A6



A-1401



A-1405 AS



A-1405 B 1
A-1405 B 2



A-1406



A-1410 BTS



A-1410 G



A-1448



A-1449



A-17036

Side mount wheel arms. Complete with frame bracket and wheel plate.

NUMBER	NAME OF PART	PRICE	NUMBER	NAME OF PART	PRICE
#1231	Spare tire blank off kit, used when rear spare bracket is removed.	5.75 set	A-1405 AS	1928-29 right or left, USA mfg.	41.00 ea.
A-1400 B16	1930-31 LH side mount arm plate	12.95	A-1405 B1	1930-31 left, USA mfg.	45.00 ea.
A-1400 B25	1930-31 RH side mount arm plate	12.95	A-1405 B2	1930-31 right, USA mfg.	45.00 ea.
A-1401	Rear wheel support bracket fits in Coupe & Roadster. Curved inner panel. 1930-31.	8.00	A-1406	1928-31 Spare wheel extension studs. Allows you to carry second spare on rear.	39.95 set
A-1401 A6	1928-29 LH or RH side mount arm plate	12.95	A-1410 BTS	Side mount arm to frame bolts	4.50
			A-1410 G	Side mount arm grommet	1.30
			A-1448	Spare Tire Bolt	1.50
			A-1449	1928-31 (upper stud for mounting spare tire carrier to the rear of the car)	2.25 ea.
			A-17036	28-31 Hand Crank	12.00

Tire Bands

* Original Licensed Product
Wright Motor Supply Co.

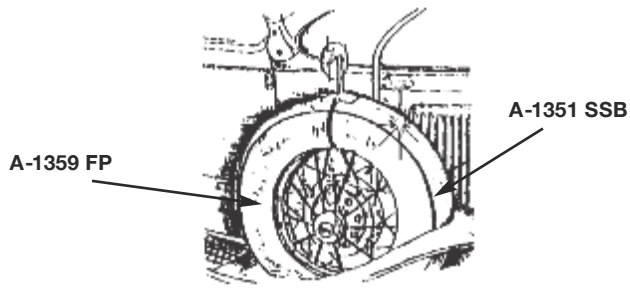

NUMBER	NAME OF PART	PRICE
A-1351 SSA	1928-29 polished stainless steel tire band	180.00
A-1351 SSB	1930-31 polished stainless steel tire band	180.00
A-1359 FP	Spare tire face plates 19", used with A-1351 SSB. Covers the tire sidewall, plain steel, must be painted	80.00

Tire Irons

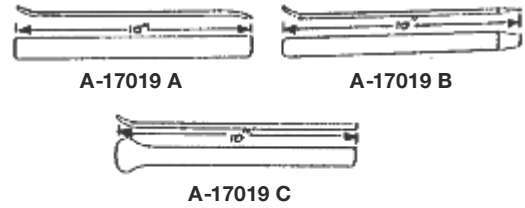

NUMBER	NAME OF PART	PRICE
A-17019 A	Tire Iron - Suitable for use or display - Tempered steel - Used through July 1928	18.25 ea.
A-17019 B	Tire Iron - Same as above, used from July 28 to November 1928	18.25 ea.
A-17019 C	Tire Iron - Same as above, used from November 1928 until end of production	22.00 ea.

Beauty Rings / Spoke Covers



Brighten up your wheels with USA-made Beauty Rings

NUMBER	NAME OF PART	PRICE
A-1396 A	21" Beauty Rings, stainless steel	Disc.
A-1396 B	19" Beauty Rings, stainless steel	Disc.
B-1397 SCA	Spoke Covers, 21" stainless steel	36.00 set
B-1397 SCB	Spoke Covers, 19" stainless steel	36.00 set

Tire Pump



NUMBER	NAME OF PART	PRICE
A-17052 A2	Tire pump, used from 1928-31, Identical to original, complete w/hose	60.00
A-17052 FP	Tire gauge face plate with screws & stop pin	6.00
A-17052 FPL	Tire gauge face plate crystal lens	6.75
A-17052 H	Tire pump hose - original cloth type finish	5.75
A-17052 HR	Tire pump hose end & clip set, original style (Non-Functional)	6.75

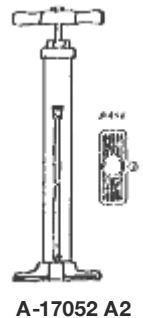

Tires



NUMBER	NAME OF PART	PRICE
A-1505 A1	21" Firestone Whitewall	197.00
A-1505 A2	21" Firestone Blackwall	158.00
A-1505 A2U	21" Universal Blackwall	99.00
A-1505 A3	21" Lucas Blackwall	99.00
A-1505 B1	19" Firestone Whitewall	197.00
A-1505 B2	19" Firestone Blackwall	156.00
A-1505 B2U	19" Universal Blackwall	99.00
A-1505 B3	19" Lucas Blackwall	99.00

Universal tires are 4 ply and have authentic tread design as used during model A production. They are oversize like the Firestone Tires.



Tubes



A-1024



A-1505 B



A-1505 BT

NUMBER	NAME OF PART	PRICE
A-1024	19" & 21" Rim liner	2.00
A-1505 A	21" Tube	15.50
A-1505 B	19" Tube	15.50
A-1505 AT	21" Metal stem tube	32.50
A-1505 BT	19" Metal stem tube	32.50

Rims

NUMBER	NAME OF PART	PRICE
A-1015 BR	1928-29 New spoke wheel, like original in primer coat 21"	330.00
A-1015 D	1930-31 New spoke wheel, like original in primer coat 19"	330.00

Metal Valve Stems



A-1501 A
A-1501 B
A-1501 RE

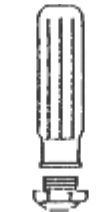

A-1503 A



A-1503 B



A-1504

NUMBER	NAME OF PART	PRICE
A-1500 N	Metal stem tube locknut (used with A-1500 W-Bridge Washer)	1.30 ea.
A-1500 W	Metal stem tube bridge washer	1.30 ea.
A-1501 A	1928-29 Stem, original style, USA	15.95 ea.
A-1501 B	1930-31 Stem, original style, USA	14.95 ea.
A-1501 RE	1928-31 Metal Valve Stem, Import	9.95
A-1503	1909-31 Tire pump check valve	21.50
A-1503 A	1928-29 Cap	19.75 ea.
A-1503 B	1930-31 Cap, fits original stem.	7.75
A-1503 BI	1930-31 Cap. Import fits A-1505 BT	9.25
A-1504	Valve stem cap	1.15

Brakes and Brake Related

* Official Leonard Product
 Steel Motor Components

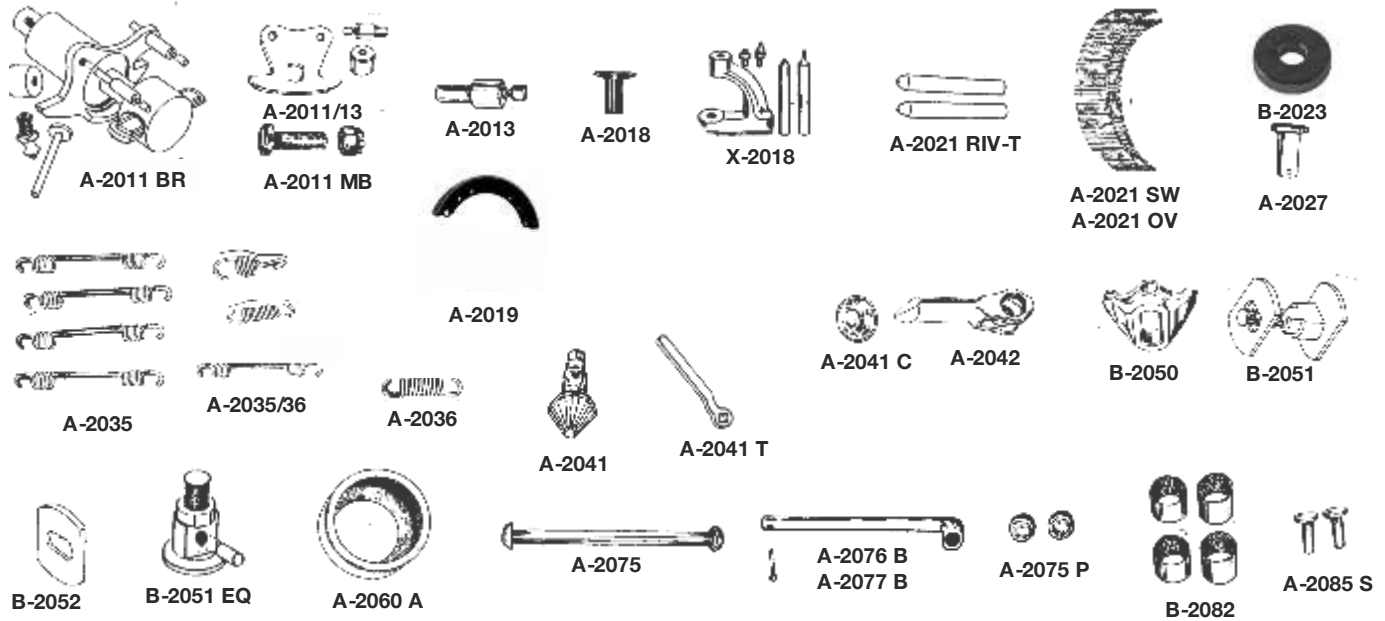

NUMBER	NAME OF PART	PRICE	NUMBER	NAME OF PART	PRICE
A-2011 BR	Rear Brake Track Assy.	89.00 set	A-2041 C	1928-31 Brake adjusting wedge cap	1.25
A-2011 MB	1928-31 Front wheel backing plate bolt set, original type bolts. 1 wheel	11.50	A-2041 T	1928-31 Brake adjustment socket tool 7/16" square. Made to fit new & worn A-2041	9.00
A-2011/13	1928-31 Front brake roller track kit, for both front wheels	20.00 set	A-2042	1928-31 Brake Adjusting Shaft	4.95
A-2013	1929-31 Brake track mounting rivets, 4 pc.	3.25 set	B-2045	1928-34 Brake Shoe Roller Pins, 8 pins per pkg.	2.95 set
A-2018	1928-31 Brake lining rivets, pkg. of 80	2.95 set	B-2050	1928-34 Brake operating wedge	18.00
X-2018	Riveting tool	24.95	B-2051	1928-34 Front brake operating wedge stud	6.75
A-2019	1928-31 Brake shoes cleaned and primed with new linings installed. EXCHANGE ONLY. Cores must be reasonably clean and not bent. Core charge \$10.00 per shoe.	18.50 ea.	B-2051 EQ	1928-34 Floating wedge bolt set. Increases brake power by allowing front brake shoes to equalize pressure.	24.95 set
A-2019 X	28-31 New Service Brake Shoe - No Lining	20.00 ea.	A-2051 EQI	1928-34 New Improved Self Energizing brake floater system. Increases brake pressure mechanically on brake shoes. For safe-stops.	160.00
A-2019 XL	28-31 New Service Brake Shoe with Lining	31.50 ea.	B-2052	1928-34 Front brake operating wedge stud washer	1.35 ea.
A-2021 OV	1928-31 1/16" oversize brake lining set to accommodate .060 oversize drums	110.00	A-2060 A	1929-31 Front brake grease baffle	24.95
A-2021 RIV-T	Rivet tool punches used to brad rivets	9.50	A-2075	1928-31 Front brake operating pin	2.25
A-2021 SW	1928-31 Service brake lining soft original woven type w/rivets, 8 pc. set	78.00	A-2075 P	1928-31 Front brake "pill." Acts as a shim to increase the length of the operating pin.	.95 pr.
B-2023	1928-34 Heat treated cadmium plated brake shoe rollers, 16 pc set	1.05 ea.	A-2076 B	1928-33 Right hand front brake operating shaft. USA Mfg.	23.00
A-2027	1928-31 Adj. shaft pins, 8 pr. per pkg.	2.95	A-2077 B	1928-33 Left hand front brake operating shaft. USA Mfg.	23.00
A-2035	1928-31 Long brake adjusting spring, 4 pc. set USA Mfg.	6.00 set	B-2082	1928-36 Front brake shaft bushings Set of 4.	.60 ea. 2.35 (4)
A-2035/36	1928-31 Complete 16 pc. set needed to replace all springs inside the brake drum, USA Mfg.	11.95	A-2084	28-31 Front Brake Shaft Lever	12.50
A-2036	1928-31 Short brake adjusting spring, 8 pc. set, USA Mfg.	5.95 set	A-2085 S	Front Brake Lever Pins	.95 pr.
A-2041	1928-31 Brake adjusting wedge	10.50			

Brakes and Brake Related

(continued)

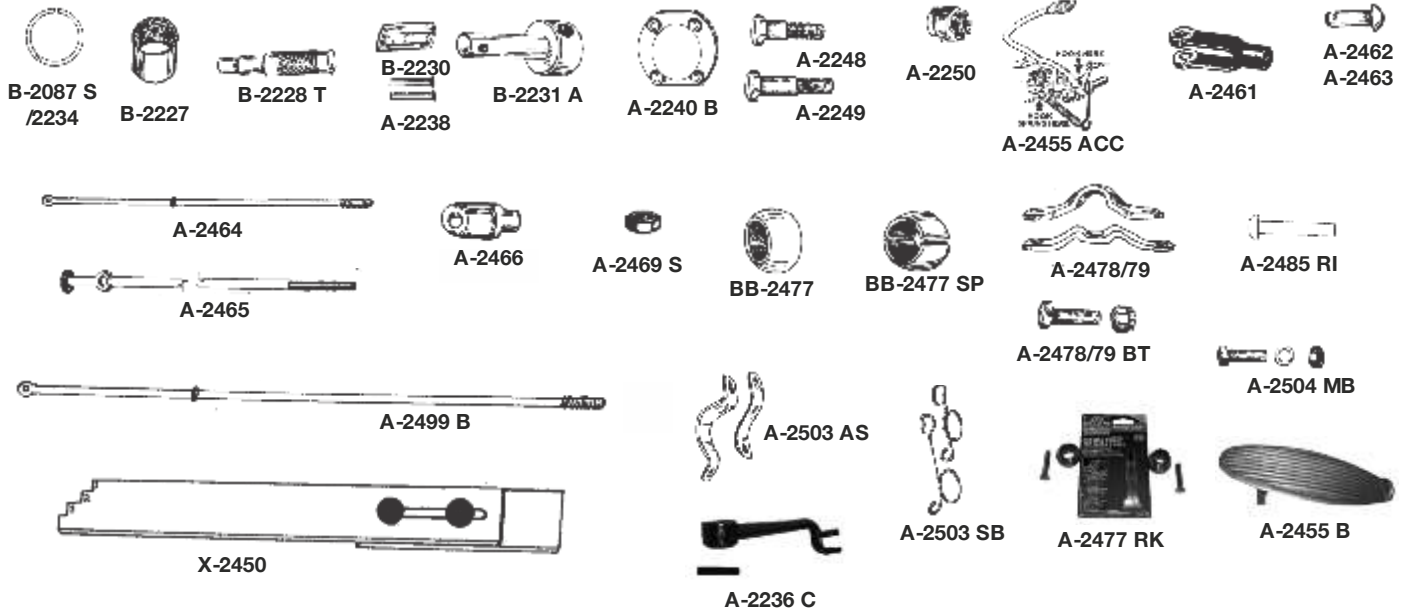

NUMBER	NAME OF PART	PRICE	NUMBER	NAME OF PART	PRICE
B-2087 S/2234	1928-36 Front & Rear brake lever dust rings	1.25 set	A-2462	1928-31 Standard clevis pin Set of 14	.20 ea. 2.50 set
B-2227	1928-34 Brake camshaft bushing for service and emergency brake shaft in rear housing. Requires 8	1.00 ea. 8.00 set	A-2463	1928-31 Oversize clevis pin .340. Often requires reaming clevis pin hole for fit Set of 14	.20 ea. 2.50 set
B-2228 T	1928-34 Brake and Shackle bushing tool	10.50 ea.	A-2464	1928-31 Forged steel emergency brake rod	13.00
B-2230	1928-34 Rear brake cam, USA mfg.	6.75	A-2465	1928-31 Pedal to cross shaft rod, USA mfg.	12.75
B-2231 A	1928-34 Rear brake camshaft, USA mfg.	10.35	A-2466	1928-31 Service brake clevis	2.50
A-2235 C	1928-31 Right rear service brake lever	12.95	A-2469 S	1928-31 Service brake clevis lock nuts.	.75 set
A-2236 C	1928-31 Left rear service brake lever	12.95	A-2477 RK	1928-31 cross shaft bushing repair kit. Repairs worn cross shaft ends with up to .020 wear. Includes Loctite which fills up to .020 gap under steel bushings.	26.00
A-2238	1928-31 Rear brake camshaft pins.	.80 pr.	BB-2477	Like original cross shaft bushing; one piece	10.00 ea.
A-2240 B	Rear brake grease baffle. Most old hubs have worn holes	7.50	BB-2477 B	1928-31 Bronze brake Cross shaft bushing 1 pc	3.75 ea.
A-2248	1928-31 Rear long brake housing/backing plate bolt	2.75	BB-2477 SP	1928-31 Split Cross shaft bushing. Can be installed without removing cross shaft end pieces. 2 pcs.	9.00 ea.
A-2248/50	1928-31 Rear housing/backing plate bolt and nut set. (One set does one wheel, 4 bolts, 4 nuts, 4 cotter pins)	16.75 set	A-2478/79	1928-31 Cross shaft brackets, 4 pc. set	8.95
A-2249	1928-31 Rear short brake housing backing plate bolt	2.25	A-2478/79 BT	Cross shaft to frame Bolts	3.75
A-2250	1928-31 Brake housing bolt nut	1.85	A-2485 RI	1928-31 Cross shaft arm rivets. Attaches arms to cross shaft.	1.00 pr.
X-2450	Brake buddy tool used to adjust the brake pedal	23.00	A-2499 B	1928-31 Forged steel service brake rod (51" long)	12.00
A-2455 ACC	1928-31 Accessory brake pedal. Anti-rattler and return spring	5.25	A-2503 AS	1928-31 Anti-rattle springs, flat type	11.50
A-2455 B	Pedal head forged steel for clutch or brake pedal, must be welded in place	16.25	A-2503 SB	Brake rod anti-rattle, Coil type, 6 pc. set	9.95
A-2461	1928-31 Two prong brake pedal rod clevis	2.80	A-2504 MB	1928-31 Anti-rattle springs mounting bolt set	1.50
			A-2236 C		

Emergency Brake

* Official Licensed Product
Stromberg-Carlson

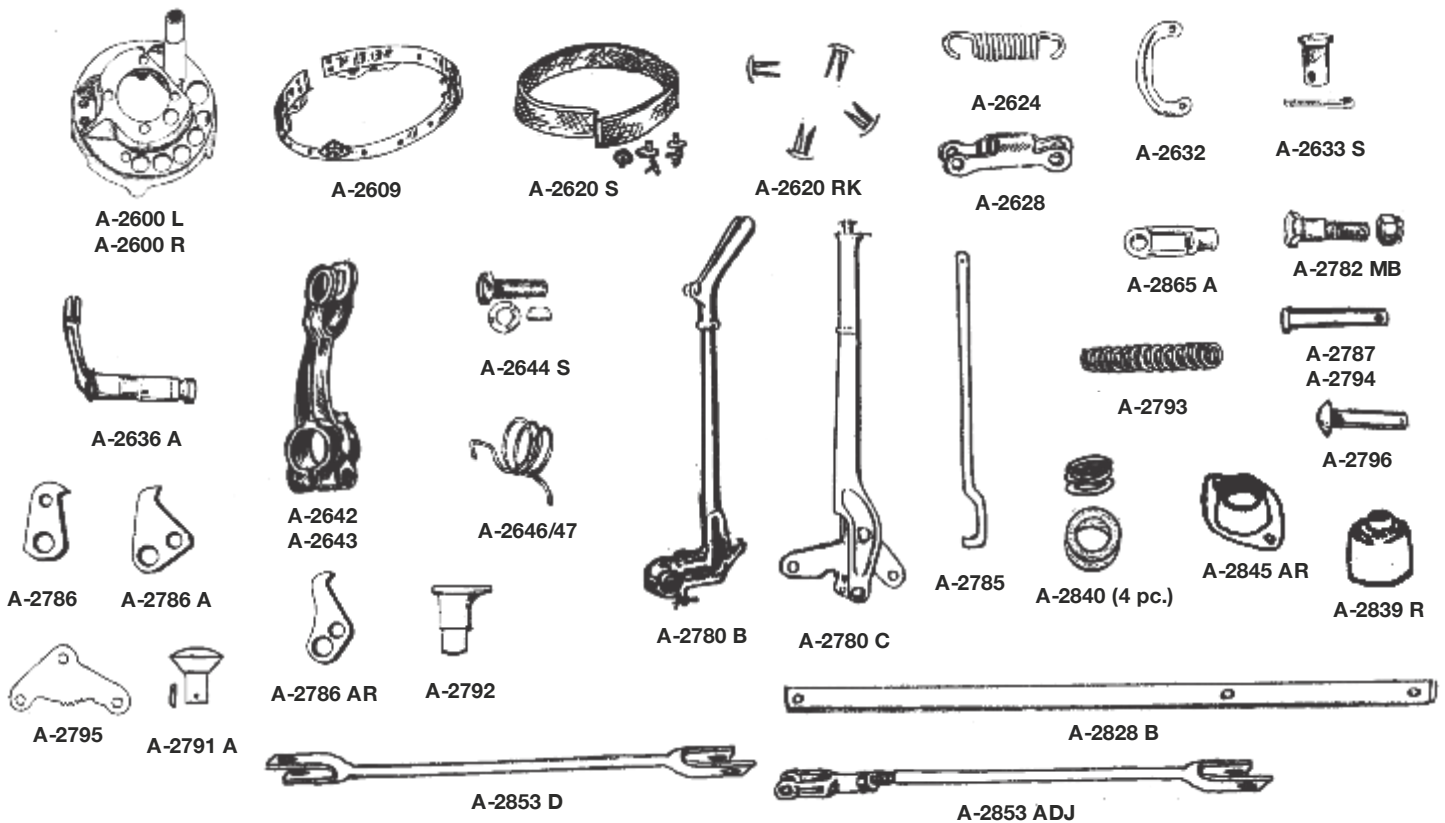

NUMBER	NAME OF PART	PRICE	NUMBER	NAME OF PART	PRICE
A-2601 L	1929-31 LH Emergency brake carrier plate	83.00	A-2786	1929-31 Emergency brake pawl, push button type. Mounts to right of gear shift.	9.75
A-2600 R	1929-31 RH Emergency brake carrier plate	83.00	A-2786 A	1928-29 Emergency brake pawl, push button type, mounts in front of gear shift.	14.95
A-2609	Emergency brake shoes, without lining	29.00 ea.	A-2786 AR	1928 Emergency brake pawl squeeze type handle.	11.70
A-2609 L	1928-31 Emergency brake shoe w/lining installed	52.00 ea.	A-2791 A	1928-31 Brake handle button	3.00
A-2620 S	1928-31 Emergency brake lining w/rivets	28.95	A-2792	1928-29 Brake Handle Button Sleeve for handle that mounts to front of transmission.	Disc.
A-2620 RK	Rivet kit for Model A Emergency	1.75 set	A-2793	1928-29 Emergency brake spring	.50
A-2624	1928-31 Emergency brake retract spring (set of 4)	2.25	A-2794	Clevis Pin that attaches the rod that runs from emergency brake handle to cross shaft. Also holds pawl in place.	.70 ea.
A-2628	1928-31 Emergency brake toggle link	8.00	A-2795	1929-31 Emergency brake handle ratchet	21.00
A-2632	Emergency Brake Horseshoe Link, forged USA	16.00	A-2795 AR	Ratchet for 1928-29 emergency brake handle	15.00
A-2633 S	1928-31 Emergency brake toggle lever pin set	2.50	A-2795 ARMB	Screw for emergency brake ratchet	1.00
A-2636 A	1928-32 Emergency Brake Toggle Lever	21.50	A-2796	Emergency brake pawl pin	.70
A-2639	1928-31 Emergency carrier plate bushing tube. Replace rusted or broken tube and brad or weld to plate.	10.50	A-2840	1928-30 Emergency brake camshaft springs and grease felts, 4 pc. set	2.25
A-2642	1928-31 Right Hand Emergency Brake Lever	13.95	A-2828 B	1930-31 Cross shaft (Emergency brake)	17.50
A-2643	1928-31 Left Hand Emergency Brake Lever	13.95	A-2839 R	1928-30 Emergency brake brass cross shaft bearing	24.00 pr.
A-2644 S	Rear emergency brake lever to camshaft, key & bolt set	1.35	A-2845 AR	1928-30 Emergency brake cross shaft brackets. Holds shaft to frame	10.95
A-2646/47	Emergency brake return spring	1.95 pr.	A-2845 X	1928-30 Emergency brake cross shaft bracket bolt set	1.50
A-2780 A	1928-29 Emergency brake handle, push button style	75.00	A-2853 A	1928-29 Emergency brake lever to cross shaft rod - single eye on one end	11.00
A-2780 B	1928-29 Pistol Grip Emergency Brake Handle Chrome Plated	75.00	A-2853 ADJ	1928-31 Hand brake rod w/adjustable clevis	11.50
A-2780 C	1930-32 Emergency Brake Handle & ratchet assy.	75.00	A-2853 D	1928-31 Handle to crossshaft Rod	10.95
A-2780 EXT	1929-31 Emergency brake handle extension	75.00	A-2865 A	1928-31 Emergency brake shaft clevis	2.50
A-2781	Early 1928 hand brake boot reinforcement plate	12.50			
A-2781 MB	1928-29 Emergency handle clamp bolt	3.25			
A-2782	Early 1928 hand brake blank off plate	12.50			
A-2782 MB	1929-31 Special thin head bolt w/castle nut that mounts on the side of the transmission	3.00			
A-2785	1929-31 Emergency brake rod, inside handle	5.00			

Front Axle

* Original Licensed Product
Drill Bits & Springs



NUMBER	NAME OF PART	PRICE	NUMBER	NAME OF PART	PRICE
A-3030 A	1928-31 Front spring perch (USA manufactured duplicate of original) with nut	60.00 ea.	A-3121	Small king pin felt, fits inside spindle bolt	.45
A-3030 B	1928-31 Front spring perch. Good quality Import	60.00	A-3123	1928-31 USA spindle bearing.	3.00
A-3034	1928-31 Front spring perch bushing	.45	A-3125	Large king pin felt, fits inside cup washer	.50
A-3035	Drill bit, 14.5 mm, used to ream spring shackle bushings.	25.00	A-3111	1928-31 Spindle bolt kit, 1/2 set shown	76.00
A-3036	1928-31 Front spring perch nut	1.50	AA-3111	1929-33 Double A truck spindle bolt kits - NOS limited supply, 1/2 set shown	135.00
A-3107	1928-31 King pin steel shim	.40	A-3111 B	1928-31 Spindle bolt bushing	1.50 ea.
			A-3111 RE	Spindle bolt reamer	140.00
			A-3111 RK	All the parts for the spindle bolt kit except the spindle bolts, 1/2 set shown	18.50 set

Tie Rod

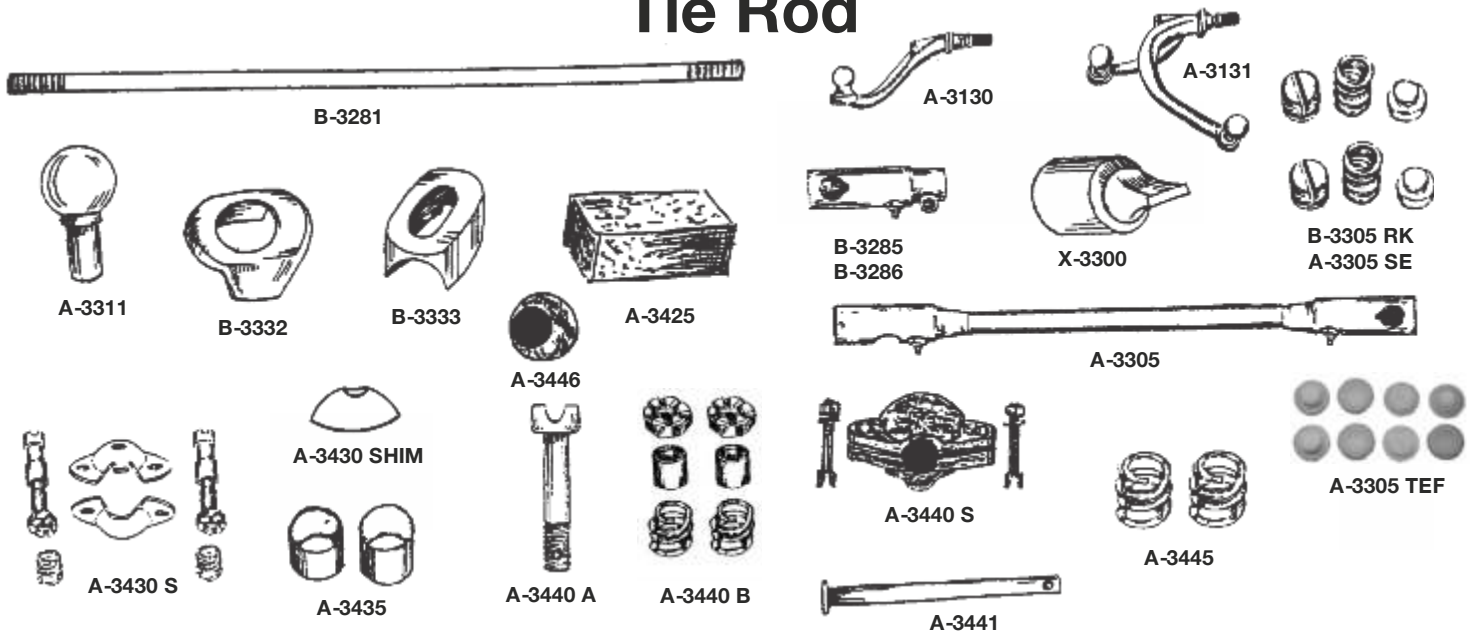

NUMBER	NAME OF PART	PRICE	NUMBER	NAME OF PART	PRICE
A-3130	Reconditioned single arm ball. Sold EXCHANGE ONLY. We must have your old unit before shipping. Exchange unit must be free of oil & grease.	37.00	B-3332	1928-37 Tie rod and drag link seal set 4 pc. set	3.00
A-3131	Reconditioned double arm ball for the left side. Sold EXCHANGE ONLY. We must have your old unit before shipping. Exchange unit must be free of oil & grease.	65.00	B-3333	1928-37 Tie rod and drag link metal cap set (Holds rubber seal in place) 4 pc. set	3.00
A-3132	Spindle arm nut	3.25	A-3405 RK2	Late 1928-30 Radius rod repair ball will not work on early 28	100.00
A-3287	1928-31 Tie rod end bolt, nut, cotter pin set	5.00	A-3405 RK3	1930-31 Radius rod repair ball	100.00
B-3281	1928-34 Tie rod only, 44" USA mfg.	16.00	A-3425	1928-31 Radius ball felt	.95
B-3285	1928-34 Right hand tie rod end housing	17.50	A-3430 S	1928-31 Radius ball cap assembly original type, pressed steel	22.50
B-3286	1928-34 Left hand tie rod end housing	17.50	A-3430 SHIM	1928-31 Shim used to take up wear on original radius rod ball. Used only with original radius ball cap assembly.	1.00
X-3300	Tie rod end tool	4.50	A-3435	Radius Ball Bushing Set	1.35
A-3305	1928-31 Drag Link, no internal parts	69.95	A-3440 A	1928-31 Front radius ball socket bolts with slotted head for retaining pin	5.00 pr.
B-3305 RK	1928-34 Tie rod or drag link kit., all internal parts for both ends of tie rod or drag link	10.50 set	A-3440 B	1928-31 Radius Rod, nut, & sleeve assembly, does not include bolts	8.25 set
A-3305 SE	Teflon seated tie rod drag link rebuild kit. Takes place of B-3305 RK. Reduces friction.	36.95	A-3440 S	1928-31 Radius rod ball cap assembly, rubber insert type, cast iron construction	7.95
A-3305 TEF	1928-31 Teflon seats only for tie rod & drag link. 8 pcs	20.00	A-3441	Radius rod ball cap pin	.95
A-3311	1928-31 Drag link ball stud (weld-in type)	3.95	A-3445	Radius Ball Spring Set	1.25
			A-3446	Radius ball cap (oil resistant neoprene)	1.75

Steering Shaft

* Official Licensed Product
World's Most Versatile

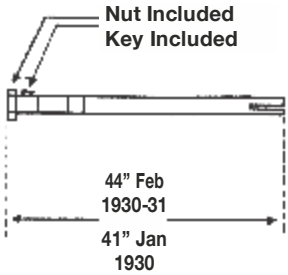

A-3524 43 GW / A-3524 44 GW

NUMBER	NAME OF PART	PRICE
A-3524 43G	1930 43" Gemmer steering shaft	85.95
A-3524 43GW	1930 43" Gemmer shaft with 2-tooth worm installed	160.00 ea.
A-3524 44G	1930-31 44" Gemmer steering shaft	85.95
A-3524 44GW	1930-31 44" Gemmer shaft with 2-tooth worm installed	160.00 ea.

Steering



A-3500B

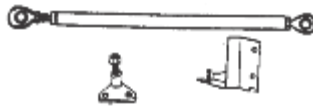

A-3500 PB



A-3500 PBR

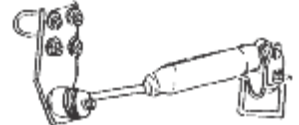

A-3500 SS



A-3507

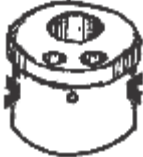

A-3517



A-3519



A-3519 BT



A-3519 DB



A-3521



A-3569

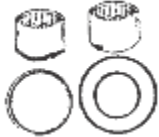

A-3574 S



A-3578



A-3590 B

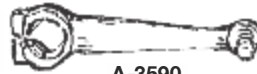

A-3590
 A-3590 RB
 A-3590 S



A-3500 GR



A-3526 T

NUMBER	NAME OF PART	PRICE	NUMBER	NAME OF PART	PRICE
A-3500 AB	1929 Rebuilt keyed steering column conversion. 7-tooth converted to 2-tooth (\$85.00 core charge. Additional charges will apply to units with damaged threads.)	650.00	A-3507	Steering column clamp	11.95
A-3500 AB	1929 Rebuilt splined steering column conversion. 7-tooth converted to 2-tooth (\$85.00 core charge. Additional charges will apply to units with damaged threads.)	700.00	A-3517	1928-29 Upper steering column bushing. For use in 1928-29 discard set screw. For use in 1930-31 do not use 2 screws.	11.75
A-3500 B	1929-31 Rebuilt steering column 2-tooth (\$85.00 core charge. Additional charges will apply to units with damaged threads) Complete unit ready to mount	550.00	A-3519	1928-31 Steering column clamp, holds steering column to dash	11.50
A-3500 PB	1928-31 Panhard bar. Makes a big difference on rough roads & handling in curves. Mounts to LF shock bolts and back of RF spring shackle	125.00	A-3519 BT	1928-31 Steering column clamp screws and lock washers	1.50
A-3500 PBR	Panhard bar, rear. Improves stability of Model A.	140.00	A-3519 DB	Steering column clamp drop bolts	5.50
A-3500 SS	Steering stabilizer. Not original but stops shimmying and darting. Installs in minutes. Fits Model A and Model T.	89.00	A-3521	Steering column anti-rattle	.75
A-3500 GR	1930-31 Rebuilt 2-tooth steering gear box and shaft only	425.00	A-3526 T	Steering shaft thread repairing tool 25-30 ft. lb. torque	11.00
			A-3569	1928-31 Light switch flange	3.75
			A-3574 S	Needle bearing and O ring set steering gear housings. Housing must be bored for 1928-31.	19.00
			A-3578	1928-31 Sector thrust screw jam nut	.70
			A-3590	1928-31 Pitman arm, now USA mfg.	35.00
			A-3590 B	1928-31 Pitman arm bolt and nut, identical to original with special head.	2.85
			A-3590 RB	1928-31 Rebuilt Pitman arm with s/s ball. Exchange only	38.00
			A-3590 S	Pitman arm (shortened)	33.95

Steering (continued)

* Original Equipment Products
Ward Air & Spring

DIAGRAM-2 TOOTH SECTOR

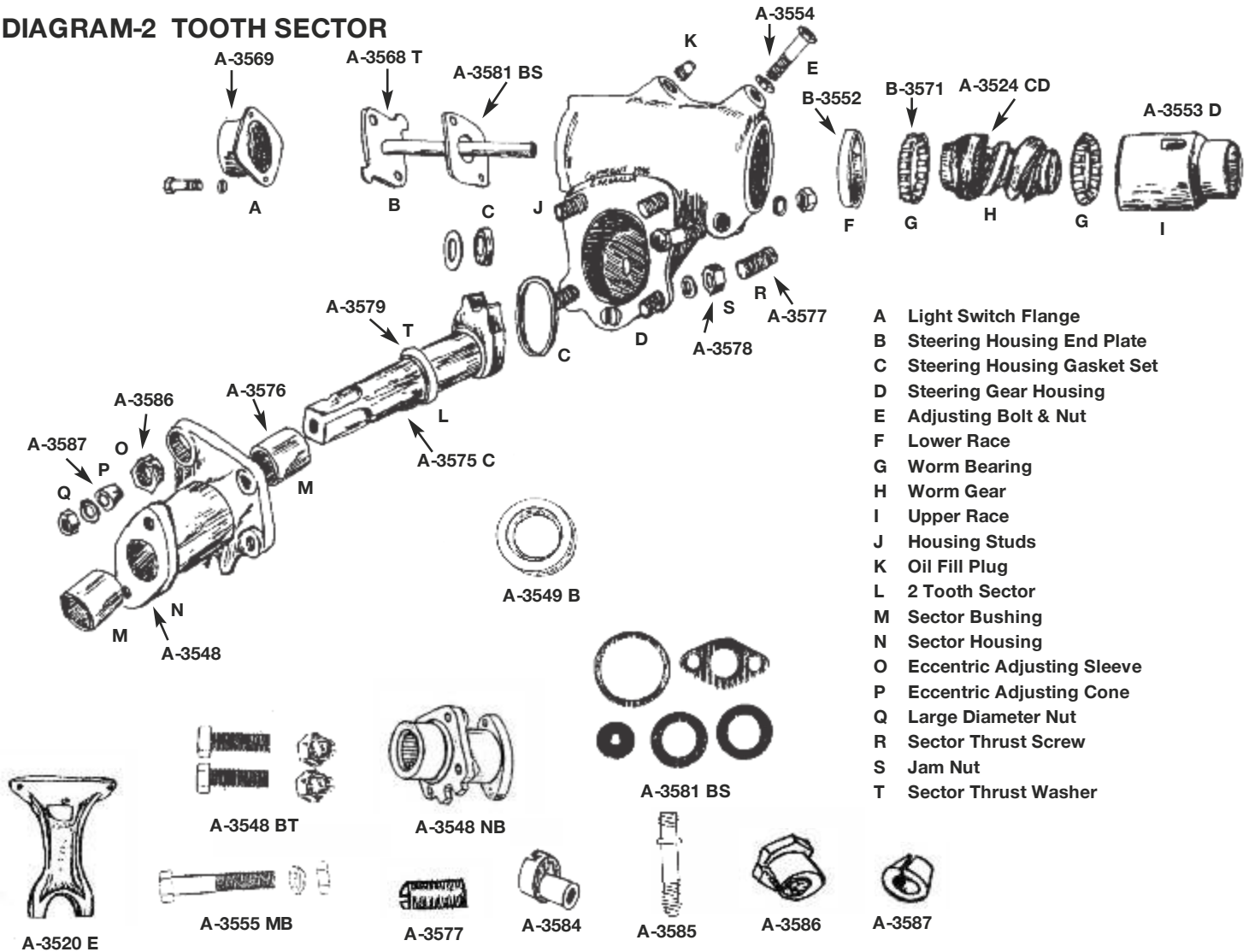

- A Light Switch Flange
- B Steering Housing End Plate
- C Steering Housing Gasket Set
- D Steering Gear Housing
- E Adjusting Bolt & Nut
- F Lower Race
- G Worm Bearing
- H Worm Gear
- I Upper Race
- J Housing Studs
- K Oil Fill Plug
- L 2 Tooth Sector
- M Sector Bushing
- N Sector Housing
- O Eccentric Adjusting Sleeve
- P Eccentric Adjusting Cone
- Q Large Diameter Nut
- R Sector Thrust Screw
- S Jam Nut
- T Sector Thrust Washer

NUMBER	NAME OF PART	PRICE	NUMBER	NAME OF PART	PRICE
30-31 Steering Gear Parts - 2 Tooth Sector					
A-3520 E	1930-31 Upper steering column support	25.00	A-3554	1929-31 Bolt/nut used to adjust upper race	3.50
A-3524 CD	Steering worm gear	60.00	A-3555 MB	1929-31 Upper race clamp bolt	.95
A-3538	1929-31 Steering box oil plug	.50	A-3568 T	Steering housing end plate & tube Prevents grease leakage. Welded	9.25
A-3548 BT	Steering Column to frame bolts	6.50	B-3571	Worm bearing - 2 tooth sector	10.50
A-3548 NB	2 tooth sector steering gear housing with needle bearing and O rings installed.	47.95	A-3575 C	2 tooth sector	102.00
A-3548 NEW	Exchange only. New steering sector with needle bearings and seal	88.00	A-3576	1930-31 2 tooth Sector bushing	2.00
A-3549 B	1930-31 Two tooth sector seal. Requires machining .250 deep and 1.625 wide. Can be used w/ A-3548 NB	5.00	A-3577	1929-31 2 tooth Sector thrust screw	2.00
A-3549 S	1929-31 Steering box stud set. 3 pcs	2.75	A-3578	1928-31 thin lock nut for sector thrust screw	.70
A-3549 W	Sector housing lock washer	.75	A-3579	1930-31 Sector thrust washer	1.30
B-3552	1929-36 Steering worm bearing lower race	15.25	A-3581 BS	1930-31 Steering gasket set	2.00
A-3553 D	Steering worm bearing upper race	34.95	A-3584	2 tooth sector housing eccentric nut	2.95
			A-3585	1930-31 Sector adjusting stud	3.50
			A-3586	2 tooth sector housing adjusting sleeve	2.60
			A-3587	2 tooth eccentric adjusting cone	2.75

Steering (continued)

* Official Licensed Product
Ward Air & Spring

DIAGRAM-7 TOOTH SECTOR

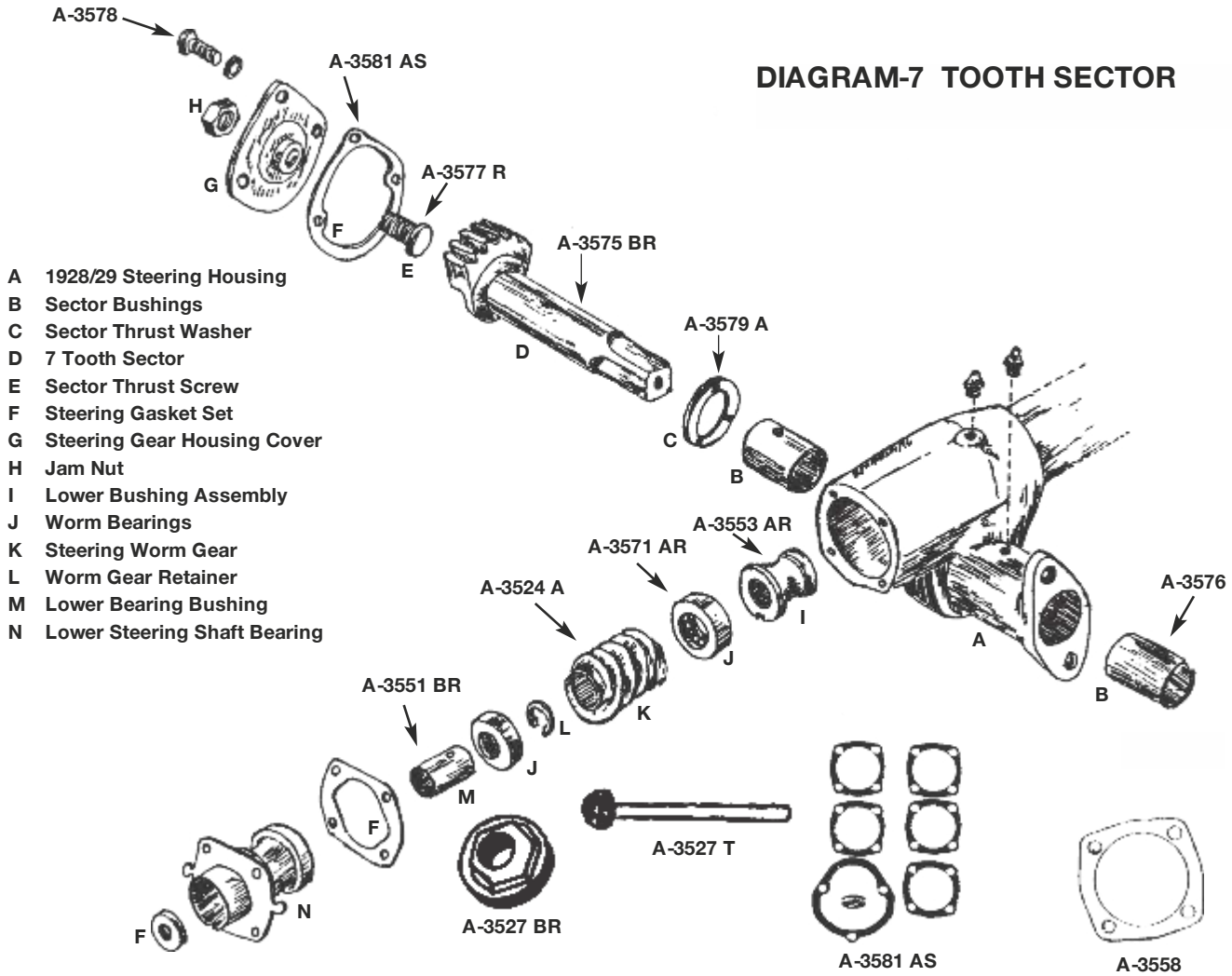

NUMBER	NAME OF PART	PRICE	NUMBER	NAME OF PART	PRICE
28-29 Steering Gear Parts - 7 Tooth Sector					
A-3524 A	1928-29 7 tooth sector worm gear	45.00	A-3558	1928-29 Steering shaft lower bearing shim	.80
A-3527 T	1928-29 7-tooth steering shaft felt retainer with tube to avoid leaking	14.50	A-3571 AR	1928-29 7 tooth worm bearing	3.00
A-3527 BR	1928-29 7-tooth steering shaft with felt retainer	6.75	A-3575 B	1928-29 7 tooth sector	85.00
A-3551	1928-29 Lower steering bushing standard	13.50	A-3576	1928-29 7 tooth sector bushing	2.00
A-3551 BR	1928-29 Oversized lower steering bushing	13.50	A-3577 R	7 tooth sector thrust screw	2.50
A-3553 AR	1928-29 7 tooth steering worm lower bushing assembly	16.95	A-3579 A	1928-29 Sector thrust washer	17.75
			A-3581 AS	1928-29 Steering gasket set	2.25

Spark & Gas Rods

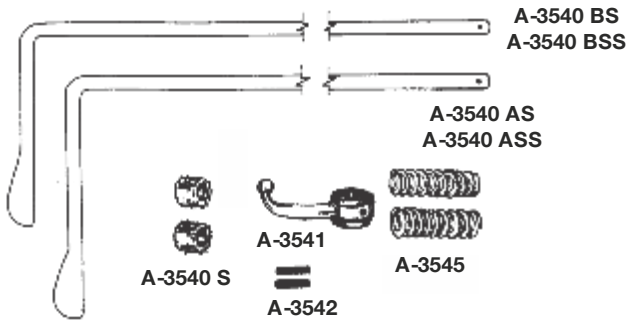

NUMBER	NAME OF PART	PRICE
A-3540 AS	1928-29 Triple plated chrome spark & gas rods	32.50 pr.
A-3540 BS	1930-31 Triple plated chrome spark & gas rods	32.50 pr.
A-3540 ASS	1928-29 Stainless spark & gas rods	45.00 pr.
A-3540 BSS	1930-31 Stainless spark & gas rods	45.00 pr.
A-3540 S	Spark/Gas Rod anti rattle	.70 pr.
A-3541	1928-31 Control lever arm. Fits on ends of spark and gas rods	5.20 ea.
A-3542	1928-31 Control rod lever pins	.35 pr.
A-3545	1928-31 Control rod lever springs	1.00 pr.

Steering Wheel

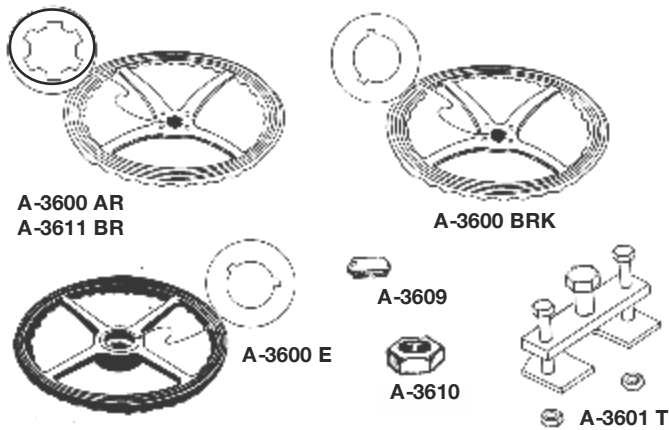

NUMBER	NAME OF PART	PRICE
A-3600 AR	1928 Red steering wheel	140.00
A-3600 ARU	1928 Red steering wheel, USA Mfg.	160.00
A-3600 BRK	1928-29 Black keyway steering wheel	99.00
A-3600 BRKU	1928-29 Keyway steering wheel, USA Mfg.	140.00
A-3611 BRU	1929 Splined steering wheel, USA Mfg.	160.00
A-3600 DKR	1928 Red keyed steering wheel for late 1929 2-tooth steering box.	145.00
A-3600 E	1930-31 Black keyway steering wheel, Import	125.00
A-3600 ES	1930-31 U.S.A. made black keyway steering wheel	175.00
A-3601 T	Steering wheel removal tool	43.00
A-3609	1928-31 Steering wheel key	.85
A-3610	1928-31 Steering wheel nut	.60
A-3611 BR	1928-29 Black steering wheel, splined Import	130.00

Light Switch

In order to supply you with the correct light switch, you must give us the correct part number according to length. Measure the tube from under the head down to the top of the light switch spider retainer groove. Some 1928-29 steering boxes will not accept reproduction rods and will require enlargement on threaded end.

New anti-rattle style horn rods with thicker tubing available by special order - 79.00.

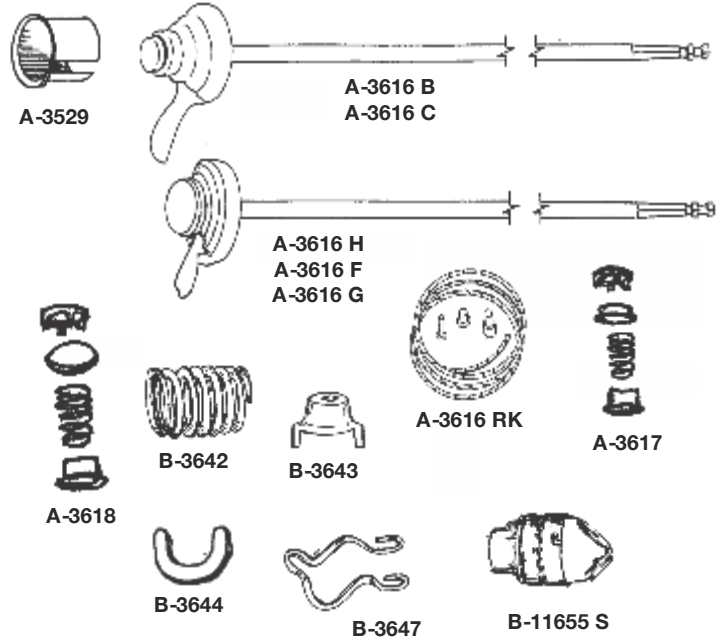

NUMBER	NAME OF PART	PRICE
A-3529	1928-31 Light Rod Bushing. Keeps light switch rod from turning when you turn steering wheel.	1.95
B-3616	1932 Light switch rod, 42-1/2"	57.00
A-3616 B	1928-29 Light switch and horn rod assembly. 45 3/4" to retainer groove	59.95
A-3616 C	1928-29 Light switch and horn rod assembly. 45" to retainer groove	59.95
A-3616 F	1930 Light switch and horn rod assembly. 45 3/4" to retainer groove	59.95
A-3616 G	1930 Light switch and horn rod assembly. 44 31/32" to retainer groove	59.95
A-3616 H	1930-31 Light switch and horn rod assembly. 45 31/32" to retainer groove.	59.95
A-3616 RK	Horn rod repair kit, replaces broken wire in the original horn rod.	4.75
A-3617	1928-29 Horn button repair kit, button, escutcheon and spring	29.00
A-3618	1930-31 Horn button repair kit, button, escutcheon and spring	29.00
B-3642	1928-39 Light switch spider spring	.65
B-3643	1928-39 Light switch spider	3.25
B-3643 T	1928-39 Light switch spider tool	7.00
B-3644	1928-39 Light switch spider retainer	.40
B-3647	1928-36 Light switch spider bail	1.75
B-11655 S	1928-39 Light switch body and housing	17.75

Rear Axle and Drive Shaft

* Official Licensed Product
World's Most Dependable

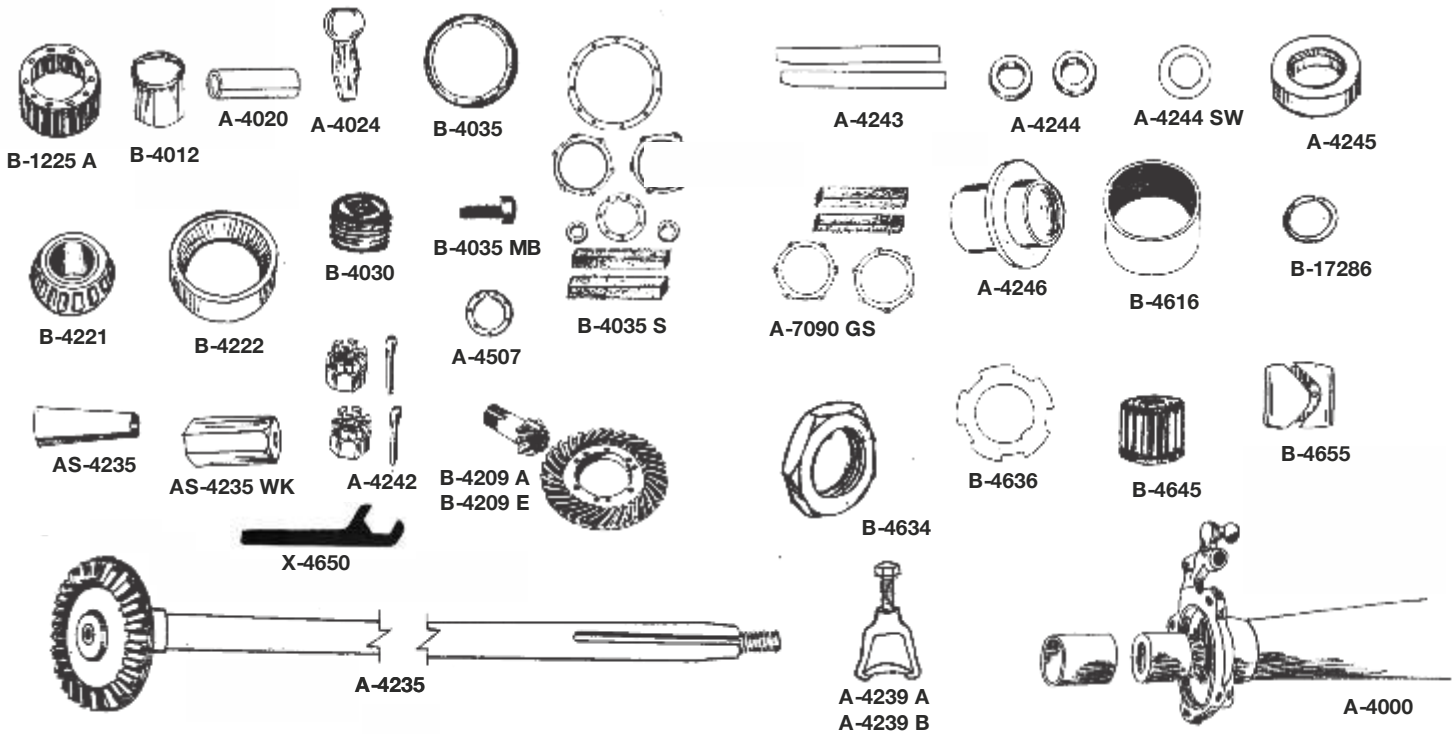

NUMBER	NAME OF PART	PRICE	NUMBER	NAME OF PART	PRICE
B-1175	1928-38 Rear wheel hub seal	3.75 ea.	A-4239 A	1929-31 Protruding hub ring puller made of strong ductile iron with a one inch thick bolt to push on axle to remove even the most stubborn hub.	32.50
B-1180	1928-38 Rear wheel seal snap ring	1.70 ea.	A-4239 B	1929-31 Recessed hub ring style puller. Same as A-4239 A except edge of puller pulls against a recessed ring instead of protruding one.	32.50
B-1225 A	1928-36 Rear wheel bearing	28.50 ea.	A-4242	1928-48 Rear axle nut set, 1 nut, 1 cotter pin	1.45 set
B-4012	1928-48 Axle housing sleeve. Used to repair axle housing bearing surfaces that are worn. Requires machine work to install.	24.50 ea.	A-4243	1928-48 Rear axle keys	1.95 pr.
A-4020	Rear spring and perch bushing	.75 ea.	A-4244	1928-48 Axle hub gaskets	.60 pr.
A-4024	Rear Spring Perch Ball	2.50 ea.	A-4244 SW	1928-31 Rear axle steel washer. Fits behind axle nut over axle hub gasket	1.00 pr.
B-4030	1928-48 Differential drain plugs	.65 ea.	A-4245	1928-48 Inner axle and drive shaft seal	2.25 ea.
B-4035 S	Rear axle and U-joint gasket set	5.00 set	A-4246	Tool, used to install A-4245 seals	8.50
B-4035	1928-32 Rear end housing gasket, .010 thick	1.25 ea.	A-4505 MB	1928-31 Torque tube to axle housing bolt set with locking wire holes	6.75
B-4035 G6	1928-32 Rear end housing gasket, .006 thick	1.25 ea.	A-4507	Torque tube to differential gasket	.50
B-4035 MB	Bolts, 20 pc. thick head raven bolts for rear end housing	13.50 set	A-4506	1928-31 Radius rod torque tube mounting bolt & nuts	2.75
B-4209 A	1928-32 9-34 (3:78 to 1) ring gear and pinion	450.00	B-4606	Drive shaft key	1.00 ea.
B-4209 E	1928-31 11-39 (3:54 to 1) High speed ring gear and pinion	465.00	B-4616	1928-34 Pinion bearing cap. Double sided cup for pinion bearings.	57.00
B-4209 HS	1923-31 (3:27 to 1) High speed ring and pinion gear	635.00	B-4634	1928-32 Pinion bearing nut	3.25
B-4221	1928-32 Differential bearings (4 needed per car)	39.00 ea.	B-4636	1928-47 Pinion lock washer	2.00
B-4221 SH	1928-48 Differential carrier bearing shim .005 thick	1.00 ea.	A-4637	Pinion thrust washer. Goes behind pinion bearing nut	1.50
B-4222	1928-32 Differential bearing cap (2 needed per car)	25.00 ea.	B-4645	1928-48 Drive shaft bearing	14.75
A-4000	1928-31 Rear axle housing machined & B-4012 installed. Exchange only. Specify side you need	Disc.	B-4655	1928-48 Drive shaft bearing sleeve	6.00
A-4235	1928-32 Rear axle.	350.00	A-7090 GS	1928-48 Universal housing gasket set	2.25 set
AS-4235	Axle shim. Used to shim worn axle or hub to prevent brake drum from rubbing backing plate.	1.80 pr.	B-17286	Speedometer gear ring	.75 ea.
AS-4235 WK	Rear wheel puller. Knock-off type. Protects axle threads from damage.	3.50	X-4650	Pinion Nut Wrench	14.00
			T-2598	1909-31 Drive shaft nut. Holds pinion gear to drive shaft	2.85

Chassis

* Official Licensed Product
Wood Block & Shims

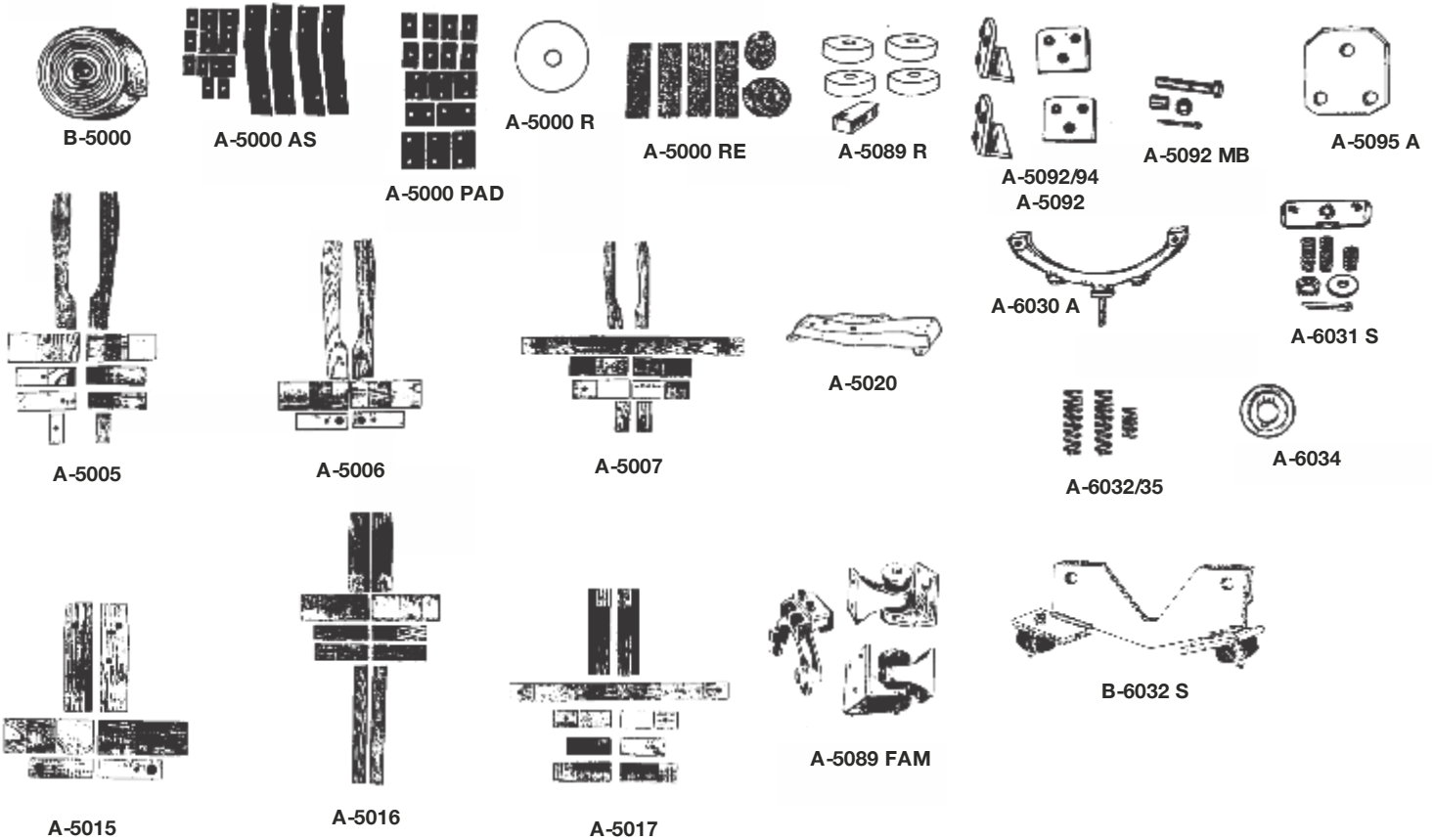

NUMBER	NAME OF PART	PRICE	NUMBER	NAME OF PART	PRICE
B-5000	Body to frame webbing, heavy duty, 20 ft.	16.00	A-5089 FAM	Float-a-motor mount kit (Accessory motor mounts replaces original and reduces engine vibration)	80.00
A-5000 AS	1928-29 Body Pads for Wood Blocks	9.50 set	A-5089 R	Replacement rubber for float-a-motor	13.00
A-5000 PAD	1930-31 Rubber pads for body wood blocks	6.25 set	A-5092 MB	1928-31 Motor mount to fly wheel housing bolt set	3.95
A-5000 R	1930-31 Round Cowl Body Pads	2.50 set	A-5091	Heavy duty frame spreader - makes installing and removing engine easier	105.00
A-5000 RE	Replacement Frame Welt Kit	Disc.	A-5092	Rear motor mount pads, flat pad only (for use with float-a-motor kit)	2.00 ea.
B-5000 SH	Body mounting shims 1/8" thick	.55 ea.	B-5092/94	1928-31 Rear motor mount pads. 4 pc. set	7.95
B-5000 SHK	Body mounting shims 1/8" thick - set of 10	5.00 set	A-5092 MB	Bolts & spacer set for rear motor mount, 24 pc. set	6.50 set
A-5005	1928-29 Passenger, except Tudor Sedan body to frame mounting block set	36.00	A-5095 A	1928-31 Rear motor mount plate fits next to rubber mounting pad on outside of frame	2.85 ea.
A-5006	1928-29 Pickup body to frame mounting block set also AA truck	28.00	A-6030 A	Motor Mount Yoke	32.00
A-5007	1928-29 Tudor Sedan body to frame mounting block set	41.00	A-6031 S	Front motor mount support kit, kits 1928-31	5.00
A-5015	1930-31 Pickup body to frame mounting block set	29.00	B-6031 SRRE	1932 Style front motor mount bolt and rubber kit	28.00
A-5016	1930-32 Coupe, Roadster & Phaeton. Body to frame mounting block set.	37.00	A-6032 MB	1928-31 Front motor mount bolts, bolts yoke to motor	2.00
A-5017	1930-31 Tudor Sedan body to frame mounting block set	41.00	B-6032 S	1928-31 Modern day replacement type front motor mount. Works well with A-5089 FAM.	60.00
A-5018	1931 Slant windshield Fordor mounting blocks.	45.00	A-6032/35	1928-31 Front Motor Mount Springs	1.60 set
A-5020	Front cross member, fits 1928-31 stamped steel as original, requires fitting	Disc.	A-6034	1928-31 Front Motor Mount Support Bushing	1.50 ea.

Battery and Battery Support Assembly

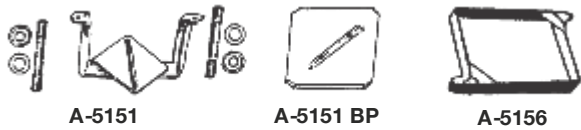

A-5151

A-5151 BP

A-5156

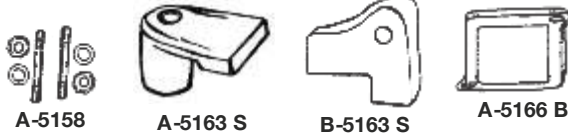

A-5158

A-5163 S

B-5163 S

A-5166 B

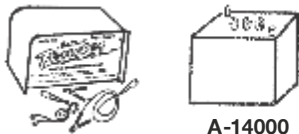

A-10000 6V CH
A-10000 12V CH

A-14000

**BATTERIES
CANNOT
BE
SHIPPED**

NUMBER	NAME OF PART	PRICE
A-5151	1928-31 Battery support assembly	19.00
A-5151 BP	1928-31 Battery support base plate	3.25
A-5156	1928-31 Battery hold down frame	6.00
A-5158	1928-31 Original design battery box stud. Two required.	2.50 ea.
A-5163 S	1928-29 Battery hold down clips	9.50 pr.
B-5163 S	1930-31 Battery hold down clips	3.95 pr.
A-5166 B	1928-31 Stamped battery hold down frame	7.25
A-5166 OP	Optima battery hold down frame	22.00
A-5170	Battery terminal protector washers red/green	3.00
A-10000 6V CH	Charges and maintains 6 volt battery without overcharge. State of the art electronics, 5 yr. warranty	Disc.
A-10000 12V CH	Same as above for 12 volt battery	Disc.
A-14000	6 volt heavy duty battery for Model A & T CANNOT SHIP	Disc.
A-14000 MAT	Battery box protector mat	4.50

Muffler



A-5230
A-5230 AR
A-5230 HP
A-5230 HPSS
A-5230 SS



A-5230 EXT



A-5230 HS



A-5234



A-5234 S



A-5251



A-5251 BS
A-5251 BSS



A-5251 DC



B-5251 ES



A-5251 MG



B-5256



A-5256 A



A-5256 B



A-5256 MB

NUMBER	NAME OF PART	PRICE	NUMBER	NAME OF PART	PRICE
**A-5230	Muffler	165.00	A-5234	Muffler exhaust sleeve. Fits inside neck of muffler and exhaust manifold. Helps prevent leaking exhaust.	4.00
**A-5230 AR	1928-31 muffler made to original Ford specifications. Made from steel as original. Lets your engine deliver more horse power. Original sound	205.00	A-5234 S	Muffler and tail pipe seal. An extra precaution in sealing exhaust. 6 oz. tube.	3.00
**A-5230 HP	1928-31 High performance black muffler. Designed for engines over 80 HP	260.00	A-5251	Muffler clamp, heavy duty durable steel. Made to original specs.	9.00
**A-5230 HPSS	1928-31 High performance stainless steel Muffler. Designed for engines over 80 HP	350.00	A-5251 BS	Muffler clamp bolt set	1.75
**A-5230 SS	1928-31 Model A Stainless Steel Muffler. New item made to original Ford blueprints with correct pipe size and baffles. Has proper sound and correct back-pressure. Lifetime purchase, no rust. Call for availability.	295.00	A-5251 BSS	Muffler clamp bolt set. Stainless steel bolts	3.00
A-5230 EXT	S/S Tail pipe Extension	12.00	A-5251 DC	Die cut asbestos ring, exhaust pipe manifold seal	Disc.
A-5230 HS	Muffler Heat Deflector. Bolts onto exhaust system and deflects heat away from floor.	36.00	B-5251 ES	Copper clad asbestos exhaust pipe manifold seal	2.95
			A-5251 MG	Woven asbestos exhaust pipe manifold seal	1.00
			B-5256	Tail pipe clamp, replacement style	2.95
			A-5256 A	1928-29 Authentic Style tail pipe Clamp. Identical to original.	6.95
			A-5256 B	1930-31 Authentic Style tail pipe Clamp. Identical to original.	6.00
			A-5256 MB	Tail pipe clamp bolt set with castle nut & cotter pin	1.75
			A-18765	1928-31 Model A cutout, also serves as Aermore whistle adapter	95.00

****Due to recent UPS changes in classification on oversize packages this item will be shipped at the 70 lb. rate resulting in a minimum charge of \$40.00 or higher. A-5230 is shipped unboxed. If you wish it shipped in a box add \$5.00 to the shipping.**

Chassis Springs & Related Items

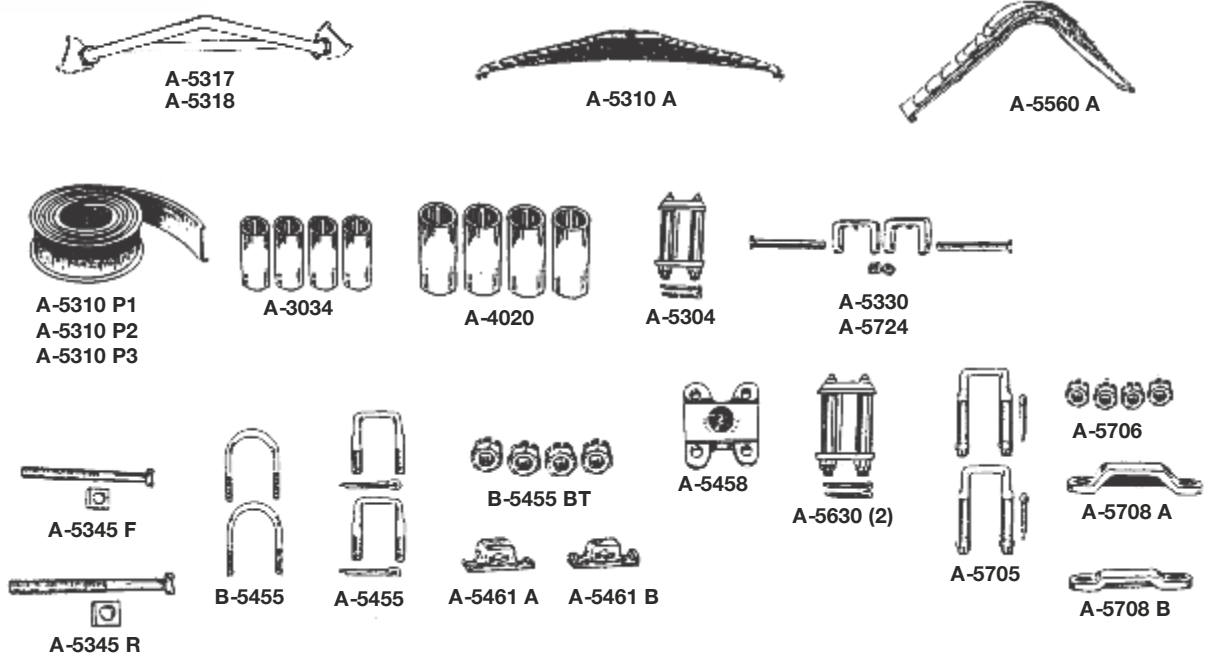

NUMBER	NAME OF PART	PRICE	NUMBER	NAME OF PART	PRICE
A-5310 P1	Black Poly-slide material for springs. Moulded lip on edge. Goes between springs to reduce friction. 20 ft. roll 1 3/4"	11.00 roll	A-5345 F	1928-31 Front center spring bolt	1.65 ea.
A-5310 P2	Same as above 2" wide, 20 ft.	12.00 roll	A-5345 R	1928-31 Rear center spring bolt	1.80 ea.
A-5310 P3	Same as above 2 1/4", 20 ft.	13.00 roll	A-5458	1928-31 Front spring lower plate	8.95 ea.
A-3034	1928-31 Front spring perch bushing	.45 ea.	A-5455	1928 Front spring U-bolt (square type)	9.00 ea.
A-4020	1928-31 Rear spring perch & shackle bushing	.75 ea.	B-5455	1928-31 Front spring U-bolts (round type) bolts only	12.00 pr.
A-5304	1928-31 Front spring shackles	16.95 pr.	B-5455 BT	1928-34 Front spring U-bolt castellated nut 4 pcs	3.50 set
A-5310 A	Front Spring, 10 leaf w/clamps & bushings	130.00 ea.	A-5560 A	10 leaf rear spring-Sedans & Pickup	280.00
A-5316	1928-31 Economy front spring spreader	50.00	A-5560 B	8 Leaf rear spring, Coupe & Phaeton & Vic.	270.00
A-5317	Rear spring spreader	80.00	A 5461 A	1928-29 Front spring U-bolt crank guide flat	14.00
A-5318	Spring spreader for rear spring. Deluxe model with ball bearings. Move in and out fast with little effort. Safe and easy to operate.	135.00	A-5461 B	1930-31 Front spring U-bolt crank guide round	11.75
*A-5330	1928-31 Script front spring clamp	3.75 pr.	A-5630	1928-31 Rear spring shackles	16.95 pr.
B-5330 SS	1928-34 Front spring clamp, stainless steel	12.00 pr.	A-5705	1928-31 Rear spring U-bolts	21.00 pr.
			A-5706	1928-31 Rear spring U-bolt castellated nuts	4.00 set
			A-5708 A	1928-31 Rear spring clip bar 7-8 leaf spring 1 1/8" High	7.50
			A-5708 B	1928-31 Rear spring clip bar 10-12 leaf spring 5/8" high	7.00
			*A-5724	1928-31 Script rear spring clamp	4.50 pr.

Engine Gasket Sets



A-6008 C

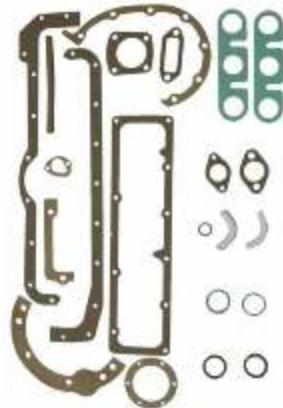

A-6008 CLH

NUMBER	NAME OF PART	PRICE
A-6008 C	Better quality engine gasket set with copper head gasket. Made in USA by long-time automotive mfg. This set includes gaskets for oil pan, oil return pipe, oil drain plug, water inlet and outlet, side timing cover, timing cover, manifold, water pump, valve cover, carburetor mounting, flywheel housing to block, front main bearing seal, early 28 oil pan clean out.	38.00
B-6008 C	1932 Model B engine gasket set, complete	39.95
A-6008 CLH	Same as A-6008 C above less the head gasket	16.00

Engine Heads and Head Gaskets



A-6010 HC
A-6010 HC6
A-6010 RB



A-6051
B-6051 AS
B-6051 BM
A-6051 M



A-6051 CC

NUMBER	NAME OF PART	PRICE
A-6010 HC	1928-31 Model A High Compression Head. 5.5 to 1	280.00 ea.
A-6010 HC6	1928-31 High compression head 6 to 1	325.00 ea.
A-6010 RB	Original rebuilt head. Model A. Repaired and pressure checked - surfaced	225.00
A-6051	Copper head gasket	26.00
A-6051 CC	Copper Coat Gasket Compound. A must for installing head gaskets. Aerosol for even application	10.00
A-6051 CCB	Copper Coat Gasket Compound Brush on type	6.00
A-6051 M	1928-31 Premium head gasket. It has solid steel core covered by high density gasket material with high temperature silicone bands surrounding water passages	33.00
B-6051 AS	1932 Asbestos Head Gasket. Can also be used on the Model A.	28.00 ea.
B-6051 BM	1932-34 Four cylinder head gasket. Same as A-6051 M. Also fits Model A High Compression Head	31.00

Engine Cams



A-6250
A-6250 A
A-6250 AB
A-6250 AR
A-6250 B
B-6250 BN

NUMBER	NAME OF PART	PRICE
REGROUND CAMS		
Original cams reground to std. Sold exchange only. Center Journal must be 1.557 or larger with good teeth for oil pump gear on unit sent in. NOS cam was 1.560		
A-6250	1928-31 Cam	65.00
A-6250 A	1928-31 high performance cam for Touring	85.00
A-6250 AB	1928-31 Model A cam ground to Model B specifications	99.95
A-6250 AR	1928 Cam	65.00
A-6250 B	1932-34 Cam	85.00
NEW CAMS		
B-6250 BN	1932-34 New cam shaft will also fit 1928-31	435.00

Engine

* Official Licensed Product
Ford Motor Company

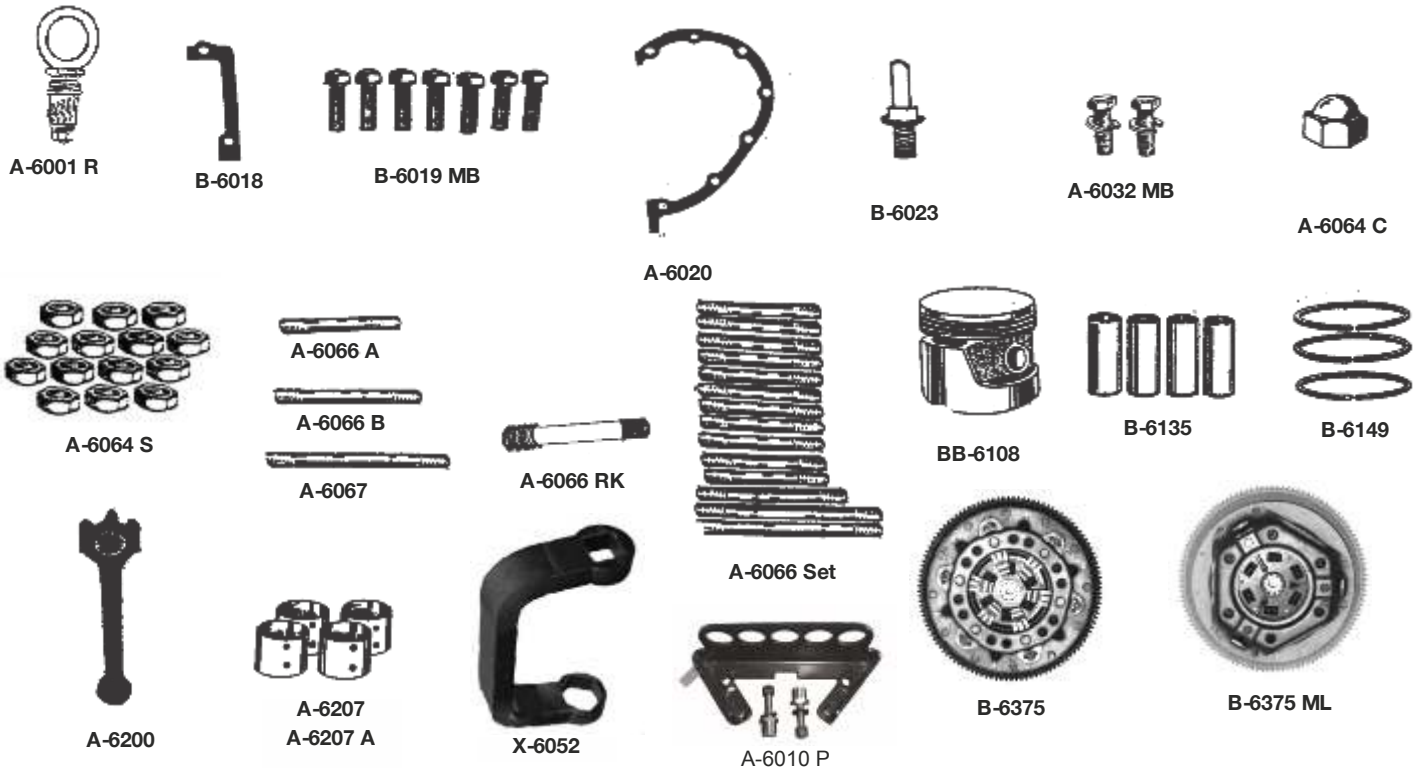

NUMBER	NAME OF PART	PRICE	NUMBER	NAME OF PART	PRICE
A-6001 R	Engine lift ring fits in spark plug hole	10.50	A-6067	Cylinder head stud 5-3/4" water outlet hsg. stud	1.60
A-6010 P	1928-31 Head puller. Tool used to remove stuck heads from the block. Can also be used to lift engine	85.00	A-6149	Piston rings Std., .020, .030, .040, .060, .080, .100, .125 old style has one piece oil ring w/expander	34.00
B-6017 MB	Side timing cover bolts	4.25	A-6200	Rebabbited connecting rods Std. B, .010 B, .020 B, .030 B, .040 B. EXCHANGE ONLY! Sold in balanced set of 4	280.00 set
B-6018	Timing gear gasket	.70	B-6200	1932 Rebabbited connecting rods Std. B, .010 B, .020 B, .030 B, .040 B. EXCHANGE ONLY! Sets are balanced	70.00 ea. 280.00 set
B-6019 MB	Timing gear cover bolts - dome head with black oxide finish as original. (7 pc. set)	3.60	BB-6108	1928-34 Good quality aluminum USA mfg. pistons. 3 ring type. State size: .020, .030, .040, .060, .080, .100 pistons, .125 pistons, STD	88.00 set
A-6020	Timing cover gasket	1.25	B-6135	Piston pin set. End lock type, STD, .003, .005	24.50 set
B-6023	Timing gear pin - identical to original.	5.00	B-6149	1928-34 Piston rings. 3 ring rail type. Std., .020, .030, .040, .060, .080, .100, .125	28.00 set
A-6028	Timing gear pin copper washer	.45	A-6149 H	Piston rings, USA mfg. by Hastings. Higher quality ring with higher ring pressure on cylinder walls. Fool proof oil ring will not allow improper installation. Specify size: std., .020, .030, .040, .060, .080, .100, .125.	36.50 set
A-6032 MB	1928-31 Front motor mount bolts	2.00 set	A-6207	Piston pin bushing set. End lock type.	6.25 set 1.60 ea.
A-6032/35	1928-31 Front motor mount spring (3)	1.60 set	A-6313	1928-31 Model A engine timing kit. All tools & instructions to time a Model A Ford with a timing light. Includes crank shaft indicator, distributor cam scale, etc.	27.00
X-6052	U-shaped head nut wrench. Used to torque under distributor	30.00			
A-6055	1928-31 Model A engine cylinder sleeves (1/8" wall)	29.95 ea.			
A-6055 TW	1928-31 Model A engine cylinder sleeves (3/32")	29.95 ea.			
A-6064 C	Chrome head nut cover	.70 ea.			
A-6064 S	Head nuts, correct size with heavy cadmium plating (14 pc. set)	.30 ea. 3.45 set			
A-6066 A	Cylinder head stud 3-1/2" long	.90			
A-6066 B	Cylinder head stud 3-3/4" used for cable clamp	1.80			
A-6066 HD	Hardened cylinder head stud set. Will not stretch. Chrome Molly with grade 5 nuts.	40.00 set			
A-6066 RK	Cylinder head repair stud 3 1/2" drill & tap (1/2 - 13) to accept	7.75 ea.			
A-6066/SET	Cylinder head stud set. Set of 14 includes 3-3/4" ignition cable stud and two water outlet studs. These studs have a domed head like the original and are hardened.	15.75			

Engine (continued)

* Official Licensed Product
Official Motor & Boat Magazine

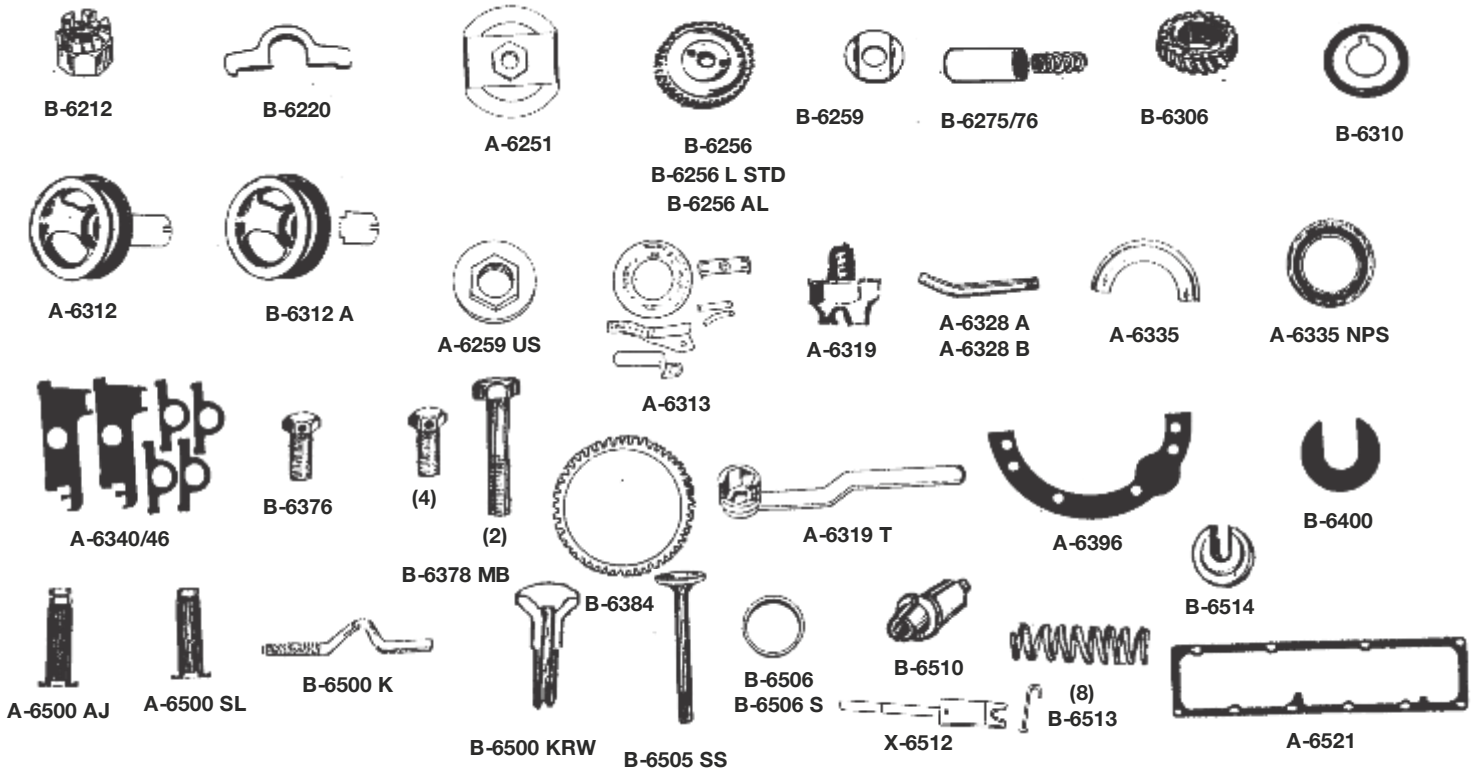

NUMBER	NAME OF PART	PRICE	NUMBER	NAME OF PART	PRICE
B-6212	Connecting rod nut	.70 ea.	B-6378 MB	Flywheel Hsg., block bolts	3.95 set
B-6220	Rod shims, laminated. Peel off for rod adjustment.	6.25 set	A-6380 MB	1928-31 Clutch housing to fly wheel housing bolts	3.50
B-6256	1928-34 Fibre camshaft gear. STD., .003 or .005	38.00	B-6384	1928-48 Flywheel ring gear	24.95
B-6256 AL	1928-34 Machined aluminum timing gear.	62.00	A-6395 X	1928-31 New ductile iron flywheel housing	325.00
B-6256 L STD	1928-34 Laminated fiberglass camshaft gear for durability. Available in .003 & .005	49.00	A-6387	1928-31 Crank shaft to flywheel dowel pin	1.45 ea.
A-6251	1928-31 Cam Nut tool. Used to install B-6259	16.95	A-6396	Flywheel housing gasket	.75 ea.
A-6253	1928-31 Camshaft dowel pins	1.20 ea.	B-6400	1928-34 Flywheel housing shim	.50 ea.
A-6259 US	Modern Camshaft nut (for easier installation and removal)	12.00	A-6500 AJ	Adjustable valve tappet. Precision double nut USA mfg. Self locking adjustment.	53.00 set
B-6259	1928-34 Camshaft nut	4.75 ea.	B-6500 K	1928-34 Valve guide tool. Used to remove valve guides.	8.00
B-6275/76	1928-34 Camshaft thrust plunger & spring	3.95	B-6500 KRW	1928-34 Valve Guide Tool, KRW, fits under valve head strike valve head to remove guide.	15.75
B-6306	1928-34 Steel crankshaft gear	13.50	A-6500 SL	Tappets, Adjustable - Single lock	71.95 set
A-6307	Crank gear key	.95 ea.	B-6505 RE SET	1928-34 Eight modern day S/S valves with slightly larger head & 1 pc. SS guides. Modern day keepers supplied.	135.00 set
B-6310	1928-34 Crankshaft oil slinger. Fits on front of crankshaft.	2.75	B-6505 SS	1928-34 Valves, intake and exhaust valves, exhaust quality, USA mfg., stainless steel	8.50 ea.
A-6312	1928-32 1 pc. cast iron crankshaft pulley	23.50	B-6505 SSX	1928-34 Modern day valves (in B-6505 RE SET)	9.95 ea.
B-6312 A	1928-32 2 pc. crankshaft pulley	29.50	B-6506	1928-34 Valve seats, hardened. Requires machining. Lasts much longer when running unleaded gas.	3.50 ea.
A-6319	Ratchet nut	12.75	B-6506 S	1928-34 Hardened valve seats for modern set	3.50 ea.
A-6319 T	Crankshaft ratchet nut tool	36.00 ea.	B-6510	1928-34 Valve guides	6.75 ea.
A-6328 A	Rear main bearing oil drain tube 5/16"	3.00	B-6510 X	1928-34 Modern day one piece valve guide (for kit B-6505 RE SET)	3.25 ea.
A-6328 B	Rear main bearing oil drain tube 3/8"	2.45	X-6512	Valve spring compression tool.	31.00
B-6328	1932-34 Rear main bearing oil tube, 3/8"	10.00	B-6513	1928-34 Valve spring	6.50 set
A-6334	Rear main thrust	45.00	B-6514	1928-34 Valve keeper	1.80
A-6335	Rear main bearing seal	12.00 ea.	B-6514 L	1928-34 Modern day two piece valve guide locks (for kit B-6505 RE SET)	.40 pr.
A-6335 NPS	Rear Bearing Neo Seal, requires machining	11.95 ea.	B-6514 X	1928-34 Modern day valve guide keepers (for kit B-6505 RE SET)	2.25 ea.
A-6340/46	Main bearing shim set laminated. Peel for adjustment.	8.00	A-6521	Valve Cover gasket - paper	1.60
B-6346/47	1932-34 Main bearing slim set	12.50	B-6521	1932 Valve cover gasket	3.50
B-6375	Flywheel, 1928-31 rebuilt assembly, balanced	275.00	A-6521 C	Valve Cover gasket - cork	2.25
B-6375 ML	1928-32 Flywheel, cut down with V8 Pressure plate, 20-25 lbs. lighter, balanced	475.00			
B-6375 V	1928-32 Flywheel, cut down with V8 Pressure plate, 10-15 lbs. lighter, balanced	380.00			
B-6376	1928-48 Flywheel bolt w/hole for safety wire (hardened)	1.80 ea. 7.00 set			

Engine (continued)

* Official Licensed Product
Small Motor & Power Tools

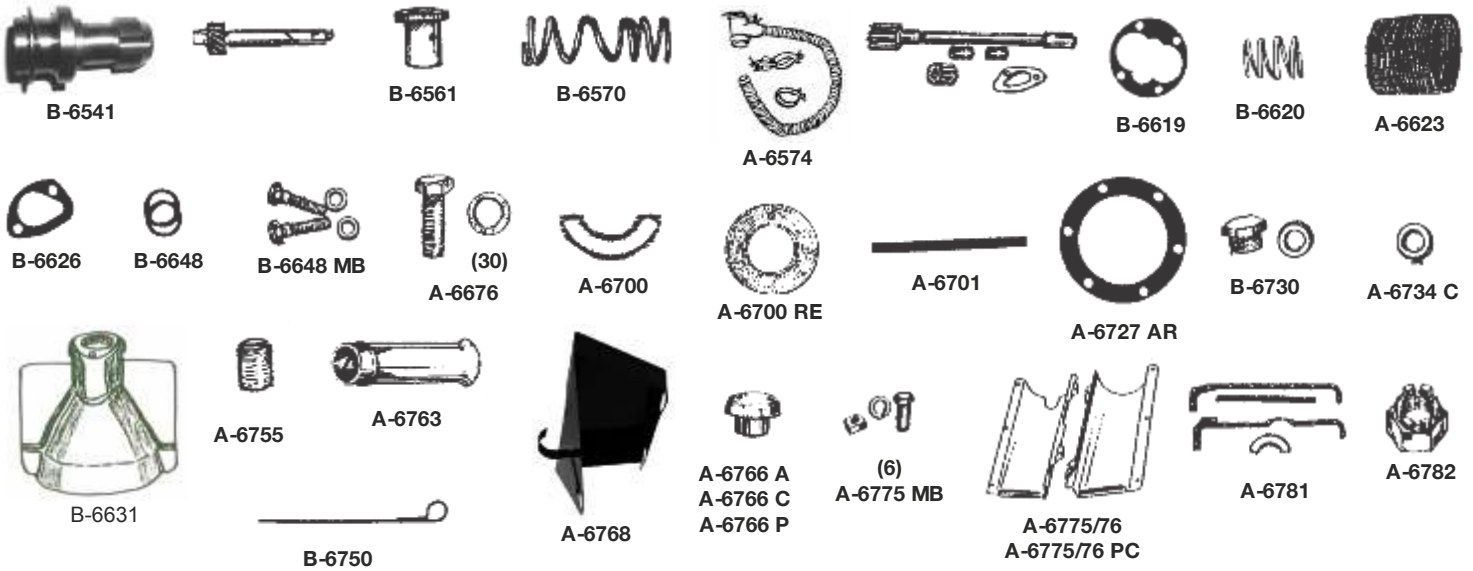

NUMBER	NAME OF PART	PRICE	NUMBER	NAME OF PART	PRICE
B-6541	Drive gear housing. Oil pump drive gear mounts in this piece and serves as a bearing.	18.50	A-6766 C	Oil filler cap, chrome plated	4.95
B-6551 P	Oil pump drive gear sleeve pin. Same as A-12196	.25	A-6763 I	Oil pipe with baffles, import	6.95
B-6551 US	1928-34 Oil pump drive gear - USA mfg.	25.50	A-6766 P	1928-31 Oil fill cap - powder coated gloss black	6.00
B-6551 .004	1928-34 Same as B-6551 US except takes up .004 backlash	24.95	A-6676	Oil pan & valve cover housing bolts. Correct black oxide finish, 60 pcs.	6.00 set
B-6551 .010	1928-34 Same as B-6551 US except takes up .010 backlash	24.95	A-6700	Main bearing seal, front packing	1.35
B-6561	1928-34 Oil pump drive gear sleeve	4.75	A-6700 RE	Modern day radial lip seal for front of crankshaft.	11.00 ea.
B-6570	1928-34 Oil pump drive gear spring	1.50	A-6701	Rear oil pan gasket	.50
A-6574	1928-31 oil breather kit. Includes oil tube, cap, and flex conduit to keep vapors out of the engine compartment.	33.50	A-6727 AR	1928 pan clean out gasket	.75
B-6600	1928-34 Oil pump kit with solid bushing - USA	25.00	B-6730	1909-38 Oil pan plug with copper gasket	3.00
B-6600 RB	1928-34 Rebuilt oil pump (core required)	65.00	A-6730 AR	Early 1928 oil drain plug	5.00
A-6612	1928-31 Oil pump bushing - solid type	.80 ea	B-6730 M	1909-38 Magnetic oil pan plug. Attracts floating metal in oil.	4.00
A-6612 AR	1928-29 Oil pump bushing - .656 OD (larger diameter)	7.00 pr.	A-6734	1928-31 Fibre oil drain plug gasket	.30
B-6618	Oil pump spring retainer clip	1.20	A-6734 C	Copper oil drain plug gasket	.55
B-6619	Oil pump cover gasket	.75 ea.	B-6750	1928-34 Dip stick	2.50
B-6620	1928-34 Oil pump retainer spring	1.00	A-6755	Oil pump set screw, in block	.55
A-6621 R	Oil pump holder tool	5.25	A-6763	Oil pipe with baffles, good fit, USA mfg.	16.50
A-6623	Brass oil pump screen	3.25	A-6763 SS	Stainless steel oil pipe with baffles	11.00
B-6626	1928-34 Oil pump screen cover gasket	.25	A-6766 A	Oil filler cap, plain steel	3.50
B-6631	1928-34 Oil pump shield. Helps to distribute oil evenly to all cylinders	12.00	A-6768	1928-31 Rear main pan, catches rear main leaks. Slips over existing bolts for easy on/off.	20.50
B-6648	Oil return pipe gasket - cork for a better seal	1.50 pr.	A-6775/76	Engine Pans	48.00 pr.
B-6648 MB	Oil pipe mounting bolt set with washers	1.50 set	A-6775 MB	Engine Pan Mounting Bolts	1.75
B-6648 W	Oil return bolt copper washer	.40 pr.	A-6775/76 PC	1928-31 Engine pans powder coated black gloss. Resists gas & oil	67.00 pr.
			A-6781	Oil pan gasket set, paper	5.50 set
			A-6781 C	Oil pan gasket set, cork	6.50 set
			B-6781	1932-34 Oil pan gasket set.	7.50 set
			A-6782	Main bearing castellated nut	.75

Transmission

* Official Licensed Product
Ford Motor Company

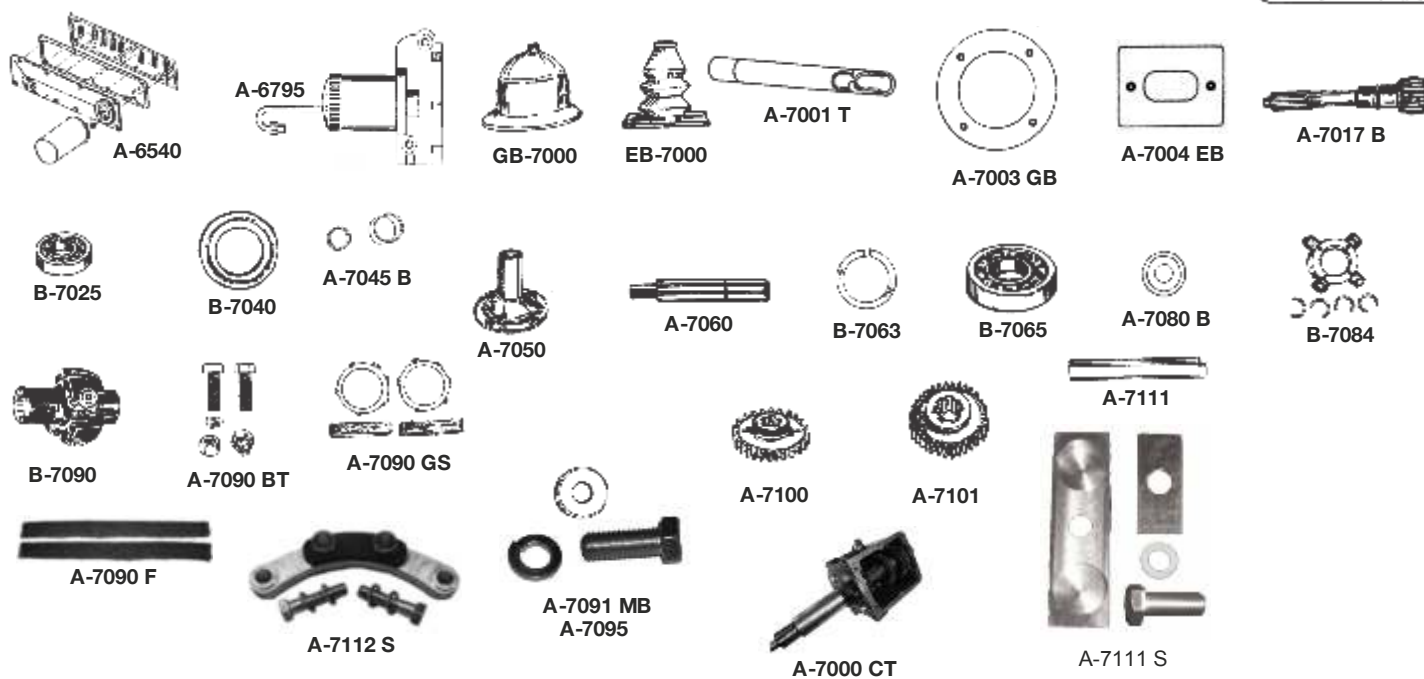

NUMBER	NAME OF PART	PRICE	NUMBER	NAME OF PART	PRICE
A-6540	1929-31 Oil Filter - This filter will filter all oil before it circulates through the engine. Original oiling concept is maintained. Filter is mounted to the side of the new valve cover. Kit includes new valve cover plate, filter, gasket, fittings and instructions. Valve cover plate is for 1929-31 style oil return pipe.	160.00	B-7040	1928-48 Main drive oil slinger	1.75
A-6795	This oil filter kit includes all needed material, including the readily available filter cartridge used on current models of Ford engines, oil line and fittings from the oil pump plug to the aluminum casting that replaces the timing gear cover. Can be installed in less than one half hour. All on the outside of the engine.	80.00	A-7045 B	1928-31 Transmission main drive gear spacer and snap ring	4.50
A-7000 CT	New complete transmission. Shift tower not included	625.00	A-7050	Transmission main drive gear retainer	Disc.
GB-7000	Gearshift boot	2.75	A-7060	Transmission main shaft, USA	90.00
EB-7000	Emergency brake boot	2.75	B-7063	1928-48 Main shaft pilot bearing spacer	.75
A-7001 T	Transmission tower spring compressor	33.00	B-7065	Main shaft ball bearing - rear	10.00
A-7003 GB	Gearshift boot rim (Polished S/S)	7.50 ea.	A-7070	1928-31 Main shaft bearing snap ring retainer - rear	1.50 ea.
A-7004 EB	Emergency brake boot rim (Polished S/S)	6.75 ea.	A-7080 B	1929-31 Main shaft bearing baffle	1.35
A-7005	1928-31 Transmission drain plug	.95	B-7084	1928-48 U-Joint repair Kit	43.50
A-7005 DK	1928-31 Transmission dipstick kit w/ floorboard access plate	30.00	B-7090	1928-48 Universal joint assembly	99.00
A-7006	1928-31 Clutch housing to transmissions bolt set - 8 pcs	2.25	B-7090 NB	1928-48 U-Joint Assy. with needle bearings	99.00
A-7017 B	Transmission main drive gear, USA	146.00	A-7090 GS	Universal gasket set	2.25
B-7025	Main drive ball bearing	13.00	A-7090 BT	Universal bolt set, 16 pc set	11.50
B-1180	1928-38 Rear wheel snap ring seal (same snap ring for bearings at each end of the transmission. Holds B-7025 & B-7065 in place.)	1.70 ea.	A-7090 F	U-Joint housing felt	1.00 pr
			A-7091 MB	Universal joint bolt with lock-washer & tabbed flat washer	1.50
			A-7092	1928-31 U-Joint bolt with special recessed washer	5.50
			A-7095	Tabbed washer, holds universal joint in place	1.00
			A-7100	Low gear slider USA	79.00
			A-7101	Intermediate gear, hi and second, USA	91.00
			A-7111	Cluster gear shaft	10.00
			A-7111 S	Transmission seal kit. Seals both transmission shafts	17.95
			A-7112 S	1928-31 Transmission shift rail and bell housing (front)	40.00

Transmission *(continued)*

* Official Licensed Product
Ford Motor Company

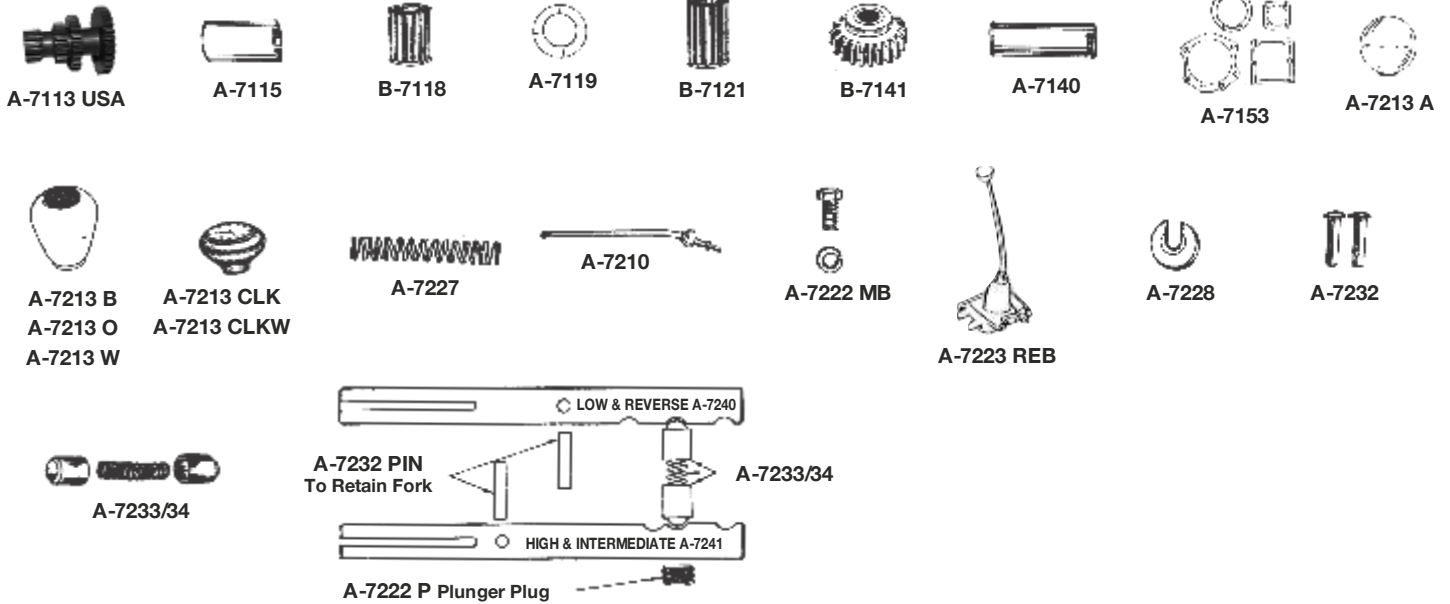

NUMBER	NAME OF PART	PRICE	NUMBER	NAME OF PART	PRICE
A-7113 USA	Cluster gear, USA mfg.	225.00	A-7222 MB	Trans. cover bolts, 12 pc set	1.75
A-7115	Trans. cluster gear bearing spacer	1.75	A-7222 P	1928-31 Transmission plunger and spring plug	1.50 ea.
B-7118	1928-50 Cluster gear & main shaft short bearing.	4.25 ea.	A-7223 REB	1928-31 Rebuilt gearshift tower with new A-7210 and miscellaneous small parts. EXCHANGE ONLY	130.00
A-7119	Cluster gear thrust washer	5.00	A-7225	Transmission tower rebuild tool kit	160.00
B-7121	1928-50 Cluster gear long bearing	4.25	A-7227	1928-31 Spring that holds the shift lever in the shifting tower	2.95
A-7140	Reverse gear idler shaft	8.00	A-7233/34	1928-31 Shifter spring with two plungers in transmission cover	4.95
B-7141	Reverse idler gear	70.00	A-7228	1928-31 Shift lever spring retainer	2.25
A-7153	Transmission gasket set	3.00	A-7230	1928-31 Transmission shifting fork - 2 required	36.00 ea.
A-7210	1928-31 Chrome gearshift lever	39.95	A-7232	Transmission shifting fork pins	.95 pr.
A-7213 A	Gear shift knob	3.20	A-7240	1928-31 Transmission tower shift rail detent shaft locks in low & reverse. Hardened & Ground	15.00 ea.
A-7213 B	1928-31 Gearshift knob (black vinyl w/Ford Script)	19.95	A-7241	1928-31 Transmission shift rail detent shaft locks in hi and intermediate. Hardened and ground	15.00 ea.
A-7213 CLK	Black gear shift knob with quartz clock. Clock can be removed to set time and change battery	27.00			
A-7213 CLKW	Same as A-7213 CLK made of walnut wood	28.50			
A-7213 O	1928-31 Gearshift knob (onyx w/Ford Script)	Disc.			
A-7213 W	1928-31 Gearshift knob (walnut w/Ford Script)	19.95			

Clutch

* Official Licensed Product
World's Most Successful

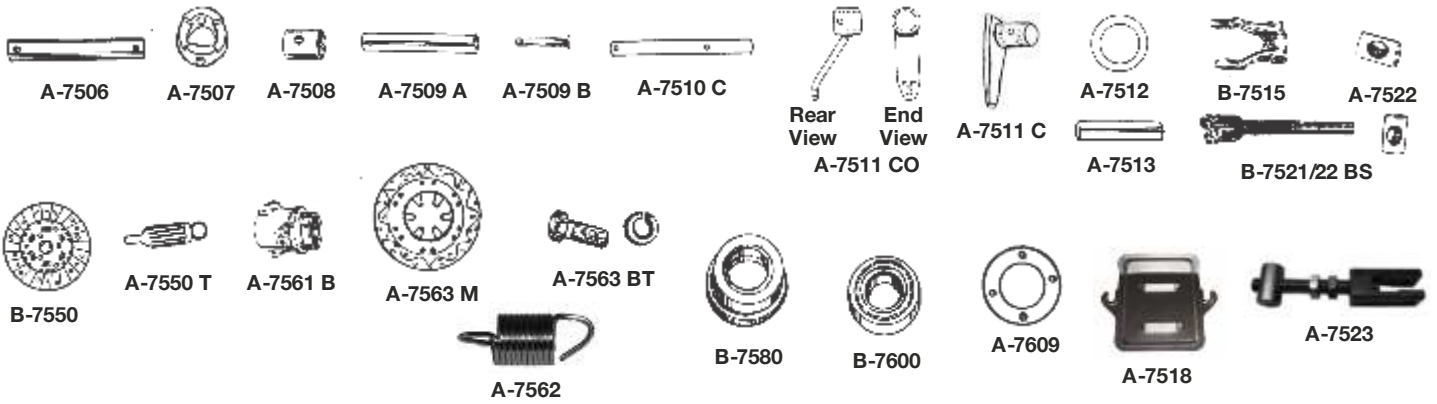

NUMBER	NAME OF PART	PRICE	NUMBER	NAME OF PART	PRICE
A-7506	Brake and clutch pedal shaft only	4.75	B-7521/22 BS	Clutch arm rod with trunnion	9.50
A-7507	Pedal shaft collar	3.75	A-7522	Trunnion nut	2.25
A-7508	Pedal bushings, 2 needed for each pedal and 2 for clutch release shaft	1.40 ea.	A-7523	1928-31 Easy clutch adjusting rod & trunnion	29.00
A-7509 A	Pedal shaft retainer pin	.55 ea.	B-7550	1928-40 Spring center clutch disc with woven lining	32.00
A-7509 B	Pedal shaft collar pin	.50	A-7550 T	Clutch disc alignment tool	3.95
A-7510 C	Clutch release shaft	8.50	A-7561 B	Throwout bearing hub	30.00
A-7511 C	Clutch release shaft arm, replacement style	24.00	A-7562	Throwout bearing spring	1.45
A-7511 CO	1928-31 Clutch lever. Manufactured 3/4" longer from hole to hole center. Decreases pedal effort approximately 30%. Makes for smoother clutch operation	19.95	A-7563	Clutch pressure plate, rebuilt (SOLD EXCHANGE ONLY)	110.00
A-7512	Spring washer, fits between clutch and brake pedal on the pedal shaft	.45	A-7563 N	1928-31 New clutch pressure plate. No exchange required	99.95
A-7513	Clutch shaft release pin	.70	B-7563 V8	1932 V8 Pressure plate - New	100.00
B-7515	1928-48 Clutch throwout fork	21.50	B-7563 MB	1932 V8 Pressure plate bolt set	8.00
A-7518	1928-31 Clutch inspection plate	10.95	A-7563 BT	Clutch pressure plate bolt set	2.40
A-7518 MB	1928-31 Clutch inspection plate screws	.50	B-7580	1928-48 Clutch throwout bearing	31.00
			B-7600	1928-63 Pilot bearing	4.00
			A-7609	1928-31 Flywheel wheel dowel retainer	2.10

Radiators and Fan Shrouds

NUMBER	NAME OF PART	PRICE
A-8006 A	1928-29 Radiator - 3 tube Heavy duty complete.	530.00
A-8006 B	1930-31 Radiator - 3 tube Heavy duty complete.	530.00
A-8006-AHD	1928-29 Super heavy duty radiator. Has more fins than A-8006 A and greater cooling capacity. 10 fins per inch.	595.00
A-8006-BHD	1930-31 Super heavy duty radiator. Has more fins than A-8006 B and greater cooling capacity. 10 fins per inch.	595.00
A-8006 AE	1928-29 3 Tube extra heavy duty radiator	585.00
A-8006 BE	1930-31 3 Tube extra heavy duty radiator	585.00
A-8050 A	1928-29 Black plastic radiator fan shroud used originally in 1928. Increases radiator efficiency. Includes mounting hardware.	69.95
A-8050 B	1930-31 Radiator fan shroud. Same as A-8050 A. Includes mounting hardware.	69.95

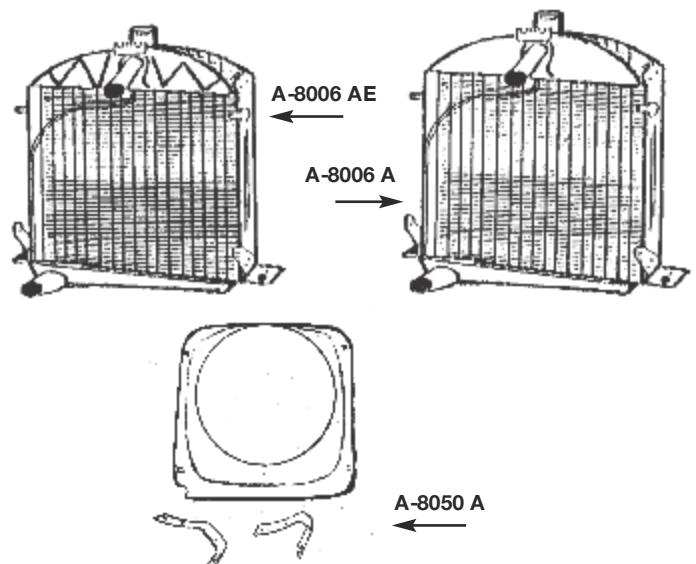

Cooling System

* Official Licensed Product
Official Ford of America

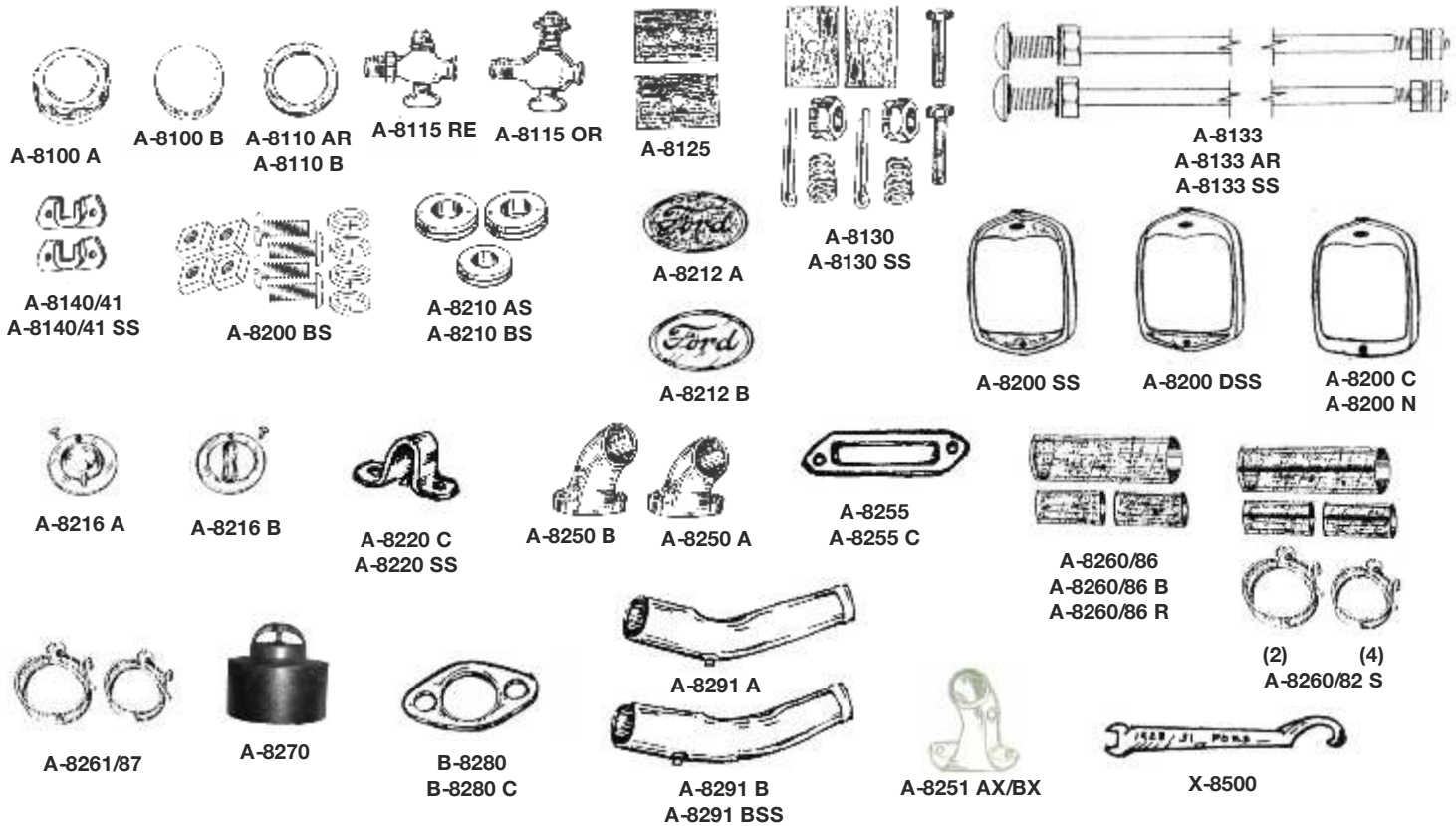

NUMBER	NAME OF PART	PRICE	NUMBER	NAME OF PART	PRICE
A-8100 A	1928-29 Radiator cap, chrome plated brass	13.25	B-8220	1932 Hood hinge retainer use with 32 style center hinge	8.35
A-8100 B	1930-31 Radiator cap, stainless	19.95	B-8221	1932 Rear center hood hinge retainer	15.50
A-8110 AR	1928-29 Original style radiator cap gasket, leather	.80	A-8220 C	1928-31 Front hood retainer clip mounts on shell	2.95
A-8110 B	1930-31 Original style radiator cap gasket, leather	.80	A-8220 SS	1928-31 Front hood hinge retainer clip	4.25
A-8115 RE	1928-31 Petcock, replacement type	7.50	A-8240 A	19" Radiator overflow tank w/ hardware polished stainless steel	50.00
A-8115 OR	1928-31 USA Original style brass petcock	9.50	A-8240 B	15" Radiator overflow tank w/ hardware polished stainless steel	48.00
A-8125	1928-31 Radiator mounting pads	.75 pr.	A-8250 A	1928-29 Water outlet	23.00
A-8130	1928-42 Radiator mounting kit	4.95	A-8250 B	1930-31 Water outlet	23.00
A-8130 RE	1928-48 Replacement style Radiator mounting Bolt set	2.75	A-8251 AX	1928-29 Water outlet neck for use w/temp gauge probe	40.00
A-8130 SS	1928-31 Radiator mounting kit, stainless steel	8.00	A-8251 BX	1930-31 Water outlet neck for use w/temp gauge probe	43.00
A-8133	1930-31 Solid radiator brace rods. Will also fit 1928-29	13.00 pr.	A-8255	1928-31 Water outlet gasket	.30
A-8133 AR	1928-29 Tubular radiator brace rods, original style	24.00 pr.	A-8255 C	1928-31 Water outlet gasket copper	4.00
A-8133 SS	1928-31 Stainless steel radiator brace rods	30.00 pr.	A-8256 P	Temperature gauge probe pipe mounts in upper radiator hose to accept temperature probe	15.00
A-8140/41	1928-31 Radiator brace rod dash bracket	3.95	A-8260/82 S	Radiator Hose kit, black hose w/red stripe & clamps - must cut large hose for 28-29	16.95
A-8140/41 SS	Same as above in stainless steel	12.95 set	A-8260/86	1928-29 Red radiator hose set	17.75
A-8200 BS	1928-31 Radiator shell mounting bolt set	1.25	A-8260/86 B	1930-31 Red radiator hose set	20.25
A-8200 DSS	1930 S/S Radiator shell, reproduction	525.00	A-8260/86 R	1928-31 Black radiator hose set	Disc.
A-8200 C	1928-29 Chrome reproduction radiator shell	165.00	A-8261/87	1928-34 Authentic type hose clamp set. 6 pc.	5.75 set
A-8200 N	1928-29 Nickel reproduction radiator shell	Disc.	A-8270	160 degree thermostat with 1 inch welded steel pipe	10.95
A-8200 S	1928-29 "Smoothie" plain steel radiator shell no holes, ready to paint	135.00	A-8255 MB	1928-31 Water inlet bolts on side of block	3.00
A-8200 SC	1928-29 Smoothie radiator shell chrome plated	163.00	B-8280	1928-34 water inlet gasket	.35
A-8200 SS	1931 S/S Radiator shell, reproduction	525.00	B-8280 C	1928-34 Copper water inlet gasket, like original	2.60
A-8210 AS	1928-29 Radiator grommet sets	2.25			
A-8210 BS	1930-31 Radiator grommet sets	2.25			
*A-8212 A	1928-30 Radiator emblem. USA mfg.	29.00			
*A-8212 B	1931 Radiator emblem	20.00			
A-8216 A	1928-29 Crank hole cover	2.40			
A-8216 B	1930-31 Crank hole cover	4.50			

Cooling System (Continued)

* Official Leeward Product
Official Leeward Products

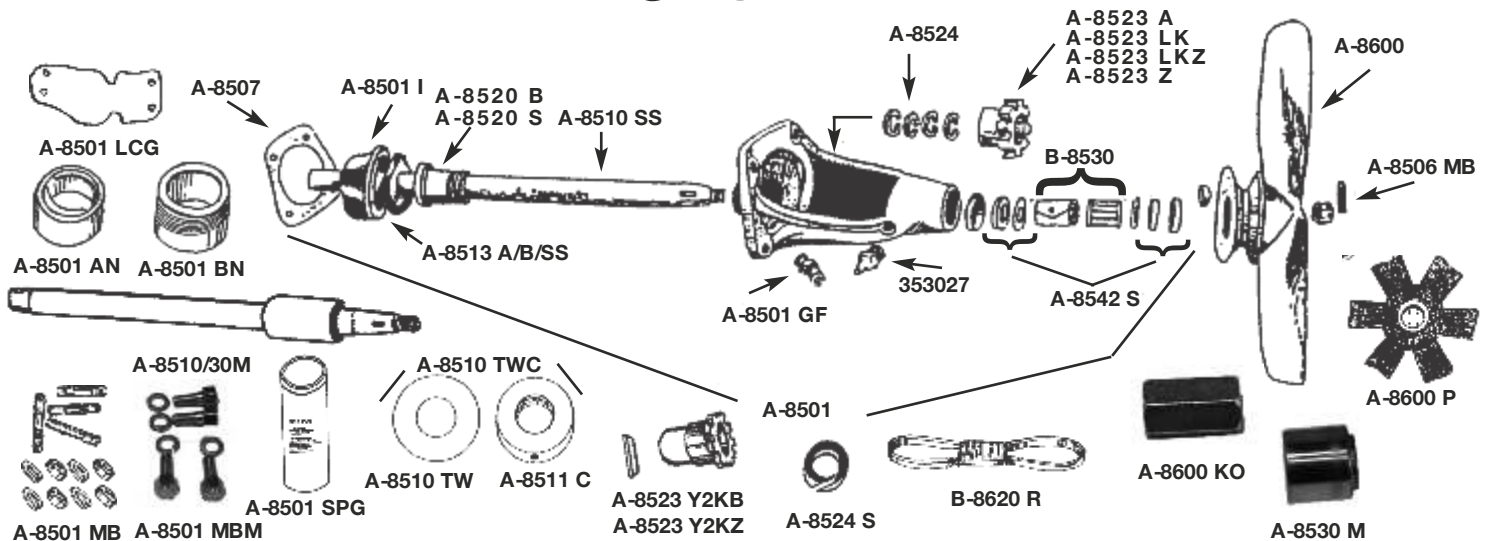

NUMBER	NAME OF PART	PRICE	NUMBER	NAME OF PART	PRICE
A-8291 A	1928 Water outlet pipe w/powerhouse generator, powder coated	11.95	A-8511 C	Water pump shaft collar 5/8"	2.25
A-8291 B	1930-31 Water outlet pipe, powder coated	11.95	A-8513 A	Water pump impeller thrust washer. Fits inside pump, steel	.70
A-8291 BSS	1930-31 Stainless steel water outlet pipe. Made to correct specifications. Mandrel bent.	18.25	A-8513 B	Water pump thrust washer. Same as A-8513 A but made of brass	1.30
X-8500	Water pump wrench	1.50	A-8513 SS	Water pump impeller thrust washer, stainless steel	1.25
A-8291 SSA	1928-29 Stainless steel water pipe outlet. Mandrel bent.	18.25	A-8520 B	1928-31 All brass as original rear bushing	7.50
A-8501	1928-31 Water pump, new original style	84.00	A-8520 S	Leakless lower bushing. Rear of bushing recessed for neoprene seal	16.00
A-8501 AN	1928-29 Radiator filler neck	25.95 ea.	A-8523 A	1928-29 Brass Water pump pack nut	8.50
A-8501 BN	1930-31 Radiator filler neck	25.95 ea.	A-8523 LK	1928-31 Leakless water pump brass pack nut. Tested & proven with modern day seals instead of packing.	17.95
A-8501 GF	1928-31 Water pump grease fitting - original	2.70	A-8523 LKZ	Same as above, Zinc nut	17.95
A-8501 I	1928-31 Water pump impeller	9.00	A-8523 Y2KB	Original looking brass pack nut w/needle bearing and modern seal	29.00
A-8501 LCG	Water pump green leather cover	7.00	A-8523 Y2KZ	Original looking zinc pack nut w/needle bearing & modern seal	29.00
A-8501 IM	1928-31 Water pump impeller. Cut down to slow water flow	10.00	A-8523 Z	1930-31 Zinc water pump pack nut	10.00
A-8501 MB	1928-31 Water pump mounting studs	2.75	A-8524	Water pump solid lead graphite split ring 3/16 (2 pcs)	3.00
A-8501 MBM	1928-31 Water pump bolts. Looks like studs. Makes pump installation easier.	5.25	A-8524 R	Water Pump packing (graphite rope type)	2.25
A-8501 SPG	STA-PUT best water pump grease available withstands hi-temperature, extreme pressure and is waterproof, 14 oz. tube	6.50	A-8524 S	Water Pump packing (solid lead graphite type split ring 5/16)	6.00
A-8506 MB	1928-31 Water pump shaft castellated nut, woodruff key, & cotter pin	1.25	B-8530	1928-34 Water pump bearing & sleeve	4.50
A-8501 Y2KB	1928-30 leak proof water pump with stainless steel shaft, modern bearings and brass A-8523 Y2KB installed, needs no grease. Also has modern ceramic seal in rear.	140.00	A-8530 M	1928-31 Modern day pump bearing & sleeve. Has a hardened sleeve. Requires pressing on	13.75
A-8501 Y2KZ	1930-31 Same as A-8501 Y2KB with zinc A-8523 Y2KZ installed, needs no grease. Also has modern ceramic seal in rear.	140.00	A-8540 A	Water pump front bearing cup washer	.50 ea.
A-8502 P	Water pump impeller roll pin	.30 ea.	A-8542	1928-31 Water pump bearing felt	.30
A-8506 KE	1928-31 Water pump woodruff key	.35	A-8542 S	Water pump seal kit, 6 pc.	2.00
A-8507	1928-31 Water pump gasket	.40	A-8554	Water Pump bearing flat washer	.30
B-8507	1932 Water pump mounting gasket	.75	A-8591 SS	1928-31 Water pump rebuild kit with stainless steel shaft with impeller installed. Leakless lower bushing. All parts except grease fittings	48.00
A-8510 ISS	Stainless steel shaft with impeller mounted	24.50	A-8600	1928-31 Fan blade assembly, one piece cast alum.	47.95
A-8510 SS	Stainless steel water pump shaft	15.00	A-8600 KO	1928-31 Model A fan blade knock off tool. Makes fan blade removal easy.	2.40
A-8510 TW	Teflon washer for pump shaft 1/16" thick	1.00	A-8600 P	1928-31 Modern plastic fan with machined steel hub. 6 blade for extra cooling.	70.00
A-8510 TWC	Collar with wear resistant washer. Put in front of pack nut to stop shaft end play	3.00	B-8620 R	1928-34 Black belt original wrapped style 43"	9.50
A-8510/30M	1928-31 Front modern day water pump cartridge pressed on stainless steel shaft. Requires arbor press fit	30.00			

Fuel System

* Original Licensed Product
Wright Aircraft Corporation

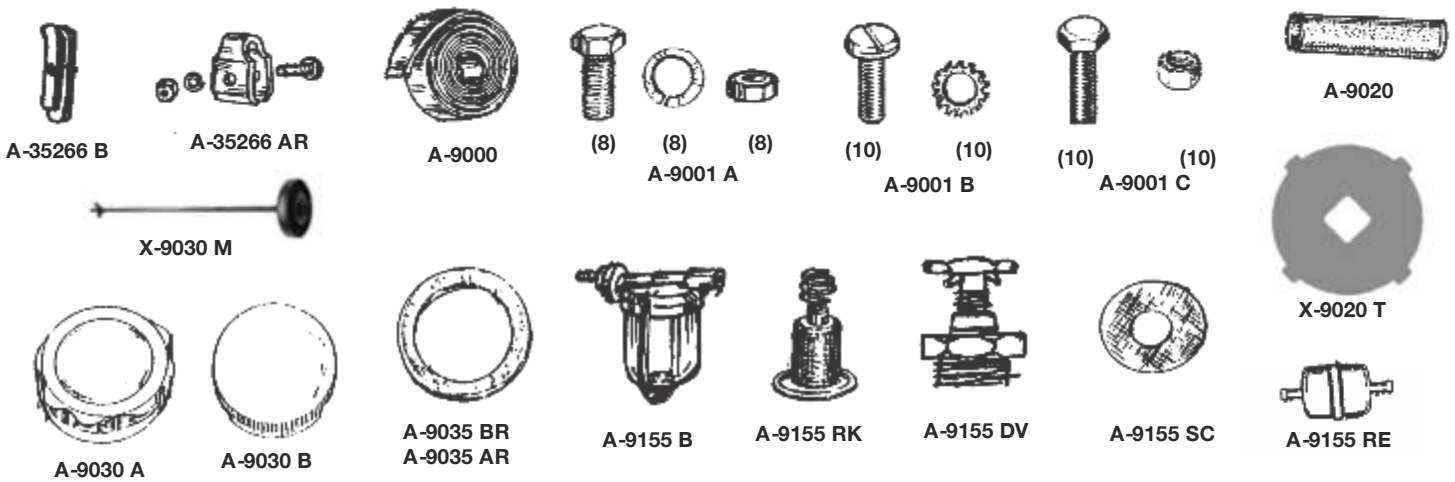

NUMBER	NAME OF PART	PRICE	NUMBER	NAME OF PART	PRICE
A-35266 AR	1928-29 Gas tank clamps. Holds tank in place. (originally used 10)	2.50 ea.	A-9066 R	1928-29 Gas tank speedometer cable grommet that fits in the hole in the tunnel under the gas tank near the firewall	3.75
A-35266 B	1930-31 Gas tank clamp. Holds tank in place (originally used 4)	2.35 ea.	A-9155 A	1928-29 Cast iron sediment bowl, rebuilt	Disc.
A-9000	Gas tank welt 10' length	5.25	A-9155 B	1928-34 Glass sediment bowl filter	29.95
A-9001 A	1928-29 Firewall to gas tank bolts with thick head.	4.25	A-9155 DV	1928-29 Drain valve assy for cast iron sediment bowl	23.00
A-9001 B	1930-31 Cowl to gas tank screw set.	2.50	A-9155 G	Replacement glass bowl for A-9155 B	6.00
A-9001 C	1930-31 Gas tank to cowl screws under windshield	3.75	A-9155 RK	1926-31 Repair kit for cast iron sediment bowl, w/o drain valve assy.	3.95
X-9020 T	1928-31 Gas tank filler screen, not threaded	10.95	A-9155 RE	In-line gas filter, can be used as additional filter, will require cutting A-9240	Disc.
A-9030 A	1928-29 Chrome plated brass gas cap	14.95	A-9155 SC	Sediment bulb screen for glass bowl	1.25
A-9030 B	1930-31 Stainless steel gas cap	20.00			
X-9030 M	Tool to pick up rust in gas tank	15.00			
A-9030 P	1926-31 Gas tank cowl protector - Lays on top of tank when filling	11.75			
X-9020 T	Gas tank filler screen tool	4.85			
A-9035 AR	1928-29 Gas cap leather gasket	.80			
A-9035 BR	1930-31 Gas cap leather gasket	.80			

Fuel System *(continued)*

* Official Licensed Product
Official Aftermarket Performance

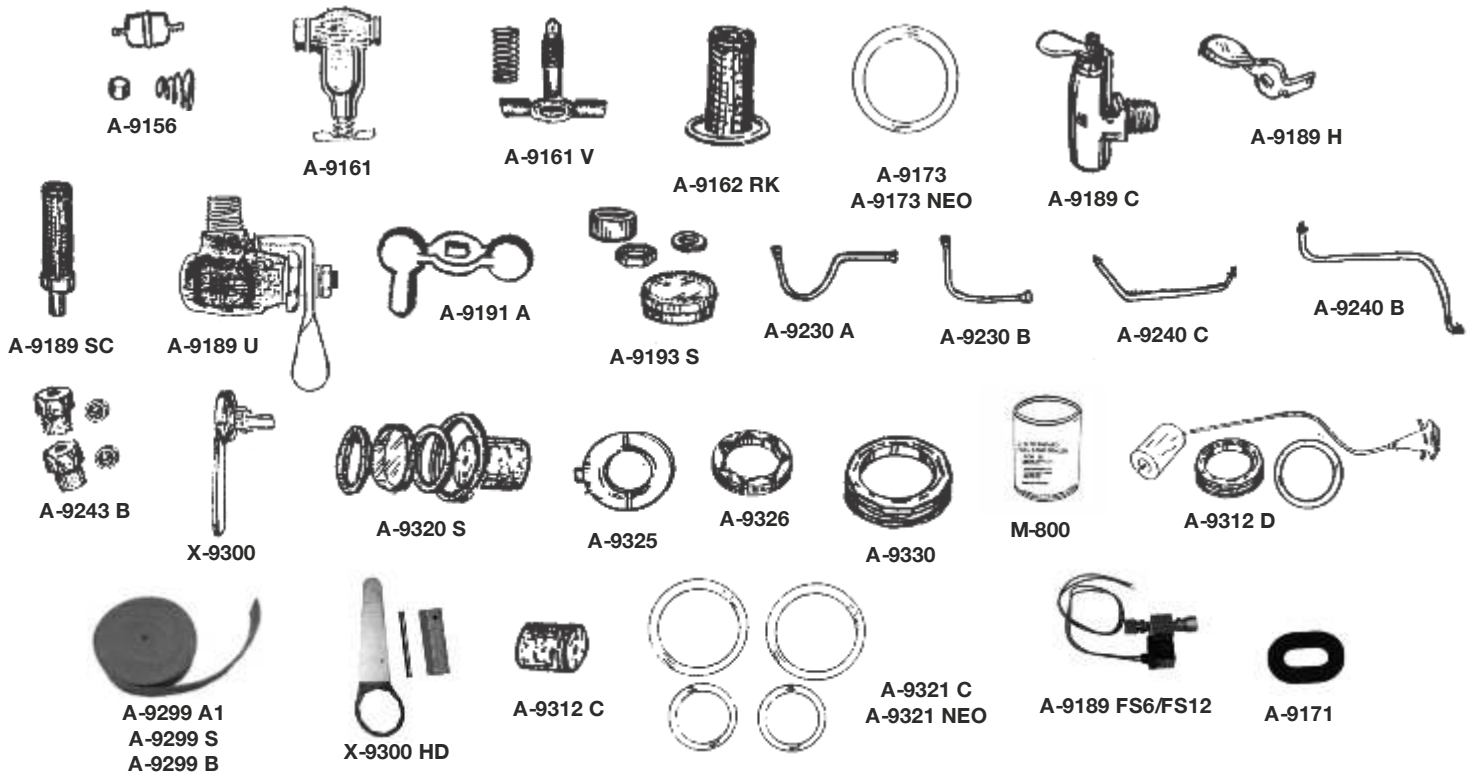

NUMBER	NAME OF PART	PRICE	NUMBER	NAME OF PART	PRICE
A-9156	Glass sediment bowl micro filter. Filters out sediment that would normally go through sediment screen.	4.25	A-9240 B	1928-31 Sediment bowl to carburetor gas line	6.00
A-9161	1931 Carburetor side mount bulb for late 1931 with hardware.	57.00	A-9240 C	Late 1931 shut-off valve to side mount bulb on carburetor gas line.	4.50
A-9161 B	1931 Side bowl filter bolt	5.00	A-9243	1/2" gas line fitting	1.75 ea.
A-9161 V	Late 1931 drain valve & spring for side mount carburetor filter	6.50	A-9243 B	9/16" head gas line fitting	1.75 ea.
A-9162 RK	Rebuild kit for late 1931 filter bowl on carburetor. Screen & gasket set	2.30	A-9299 AI	1928-29 Gas tank anti-squeak Fordor Sedan	2.45
A-9171	Fuel valve grommet for late 1931 firewall	2.50	A-9299 S	1928-29 Gas tank anti-squeak all other	2.25
A-9173	Cork gasket for glass sediment bowl	.35	A-9299 B	1930-31 Gas tank anti-squeak all models	2.25
A-9173 NEO	Neoprene gasket for glass sediment bowl	.40	X-9300	Gas gauge tool set, aluminum	6.25
A-9189 C	1931 Gas shut-off valve for late 1931	36.95	X-9300 HD	Heavy duty gas gauge tool for shop use	10.95
A-9189 FS6	Electric fuel shut off valve. Automatically cuts off fuel when ignition switch is turned off. Installs in gas line under hood. Complete with instructions. (6 Volt)	60.00	A-9312 C	Gas gauge cork float	1.50
A-9189 FS12	Same as A-9189 FS6 for 12 volt systems.	60.00	A-9312 D	Gas gauge dial, rod, and float assy. with inner and outer nuts	38.50
A-9189 H	Fuel shut-off valve handle	2.95	A-9313 BR	Brass gas gauge float	10.00
A-9189 SC	Shut-off valve screen. Fits in the end of A-9189 U that screws into tank and prevents trash from entering gas line.	3.75	A-9313 C	Gas gauge float. Made from modern day material. Alcohol proof. Guaranteed not to sink.	3.95
A-9189 U	1928-31 Gas shut-off valve (USA) All brass	31.95	A-9320 S	Gas gauge rebuild kit. Includes gaskets, lens and float.	4.95
A-9191 A	1928 to April 1929 Gas shut off valve handle	12.25	A-9321 C	Cork gas gauge gasket set	1.00
A-9193	1928-31 Gas valve packing only	.95	A-9321 NEO	Neoprene gas gauge gasket set with brass shim	1.50
A-9193 S	Shut-off valve repair kit	1.60	A-9325	Gas gauge face plate	2.10
A-9230 A	1928-29 Gas tank to firewall gas line	9.50	A-9326	Inner gas gauge nut	7.00
A-9230 AE	1928-29 Inside gas line with electric shut off valve installed	89.95	A-9330	Outer gas gauge nut	7.00
A-9230 B	1930-31 Gas tank to firewall gas line	8.50	A-9331	Brass slip ring for outer gas gauge nut	1.25
A-9230 BE	1930-31 Inside gas line with electric shut off valve installed	89.95	M-800	Gas tank sealer, alcohol resistant, qt.	39.00
			A-9349 6V	6V electric fuel pump	54.50
			A-9349 12V	12V electric fuel pump	54.50

Exhaust Manifold

* Official Licensed Product
Official Merchandise of the Ford Mustang



A-9430 Assy



A-9430 US



A-9425



A-9431

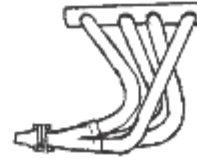

A-9430 H



A-9425 DD

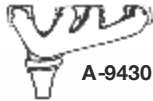

A-9430 CIH



A-9425 MB



B-9433 A
 A-9433 C-2

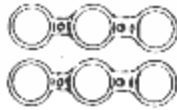

A-9433 C



B-9433 B



B-9440



(4) (4)
 B-9443

FORD PART NUMBER

FORD PART NUMBER	NAME OF PART	PRICE	NUMBER	NAME OF PART	PRICE
A-6755	Intake Manifold Plug	.55	B-9433 A	1928-34 Exhaust manifold gasket 2 pc asbestos	2.75
A-9425	Intake manifold. New.	90.95	B-9433 B	1928-34 Exhaust manifold gasket 1 pc asbestos w/metal on one side, USA mfg.	4.95
A-9425 DD	Intake manifold. Aluminum down draft. Use Stromberg V8 carburetor	275.00	A-9433 C	1928-34 Copper/Asbestos exhaust manifold gasket. Used Jan. 1929 until May 1931. Identical to original 2-piece.	12.50
A-9425 MB	Intake Exhaust Manifold Bolts	.75 set	A-9433 C-2	1928-34 Late 1931 copper/asbestos exhaust manifold gasket, 2 pc.	12.50
A-9430 BN	Brass Exhaust Manifold Nuts (set of 4)	3.35 set	B-9440	1928-34 Gland rings (4 ea. fit into the manifold to form a tight seal)	2.75
A-9430 CIH	1928-31 Heat treated cast iron header. More power & performance. USA mfg.	295.00	B-9443	1928-34 Manifold stud washer set & nuts. Heavy cupped washers like original.	5.75
A-9430 MC	Stainless steel Model A Manifold cooker	65.00			
A-9430 US	Exhaust manifold, US mfg.	95.00			
A-9431	Exhaust manifold studs	3.50 set			

Hats

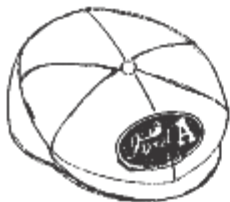

#16



#19



#18

NUMBER	NAME OF PART	PRICE
#16	Gatsby style driving hat. One size fits all. White cotton with your choice of patch. Specify one of the following: Ford, Ford T, Ford A, Ford V8 or Mustang. Men & Women like this one.	18.75
#18	Blue Baseball Sport Cap with Ford A Patch	7.00
#19	Blue Baseball Sport Cap with Ford T Patch	7.00

Car Covers

A poly cotton material for indoor storage. **Dust cover only.**

NUMBER	NAME OF PART	PRICE
A-789678 C	1928--31 Coupe	175.00
A-789678 P	1928-31 Pickup	175.00
A-789678 R	1928-31 Roadster	175.00
A-789678 S	1928-31 Sedan	190.00

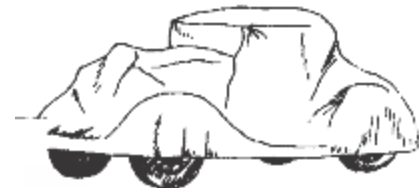

A-789678 C

T-Shirt

NUMBER	NAME OF PART	PRICE
20	Tee shirt with Smith & Jones logo.	8.95



20

Carburetors (Continued)

* Official Licensed Product
Official Aftermarket Accessories



A-9600
A-9600 SS
A-9600 T



A-9600 FI



A-9600 ZA



A-9591



A-9577 TAP



B-9595



A-9581 BT



A-9581 S

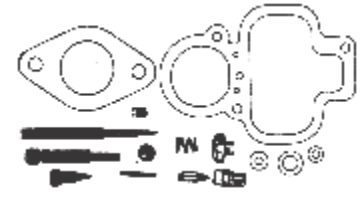

A-9590 T

NUMBER	NAME OF PART	PRICE	NUMBER	NAME OF PART	PRICE
A-9575	Zenith compensator jet	2.95	A-9590 T	Tillotson carburetor rebuild kit	19.50
A-9576	Zenith Carb. 4 pc. passage plug set. Replaces plugs that must be drilled out to remove rust.	2.75 set	A-9590 ZK	Carburetor rebuild kit for replacement Zenith (Fits A-9510 Z)	33.00
A-9577 B	Large head brass Zenith carburetor idle mixture screw with stainless spring and brass cap	3.75	A-9591	Zenith carburetor housing bolt	.90
A-9577 C	Large head cadmium Zenith carburetor idle mixture screw with stainless spring & brass cap	3.25	A-9595	Zenith carburetor rebuild set	29.50
A-9577 TAP	Special 10-34 thread cleaning tap for idle adjusting screw and jet	6.50	B-9595	1932 Model B Zenith carburetor rebuild kit	49.00
A-9581	Zenith throttle shaft std.	16.50	A-9600	Air maze. Fits Zenith, fits Tillotson with modifications	26.00
A-9581 B	Zenith throttle shaft oversize	19.50	A-9600 ACC	Air maze, high volume type. Has a large filter and will work with engine splash pans.	34.00
A-9581 BT	Tillotson throttle shaft bushing	6.00 pr.	A-9600 ADP	Adapter used to convert original style air maze to high volume filter for more efficiency.	5.65
A-9581 S	Zenith throttle shaft bushing, drill upper body and install, 2 needed	.90 ea.	A-9600 FI	Paper filter element for air maze	10.00 ea.
A-9585	Zenith throttle plate	6.10	A-9600 HV	Air filter, high volume. 5 1/4" tall 4 3/8" diameter. Requires adaptor kit A-9600 ADP to adapt from original air maze.	10.50
A-9586	Zenith carburetor venturi	4.95	A-9600 T	1928-31 Tillotson Air Maze	30.00
A-9586 AR	Early 1928 double venturi - USA	33.00	A-9600 SS	Zenith air maze with stainless steel screen	28.00
A-9590	Zenith lower plug	2.00	A-9600 SSF	Air maze stainless steel screen	9.75
A-9590 C	1930-31 Cadmium Drain Plug	1.50	A-9600 WF	Weber carburetor air filter	16.00

Spark and Carburetor Controls



A-9700 B
A-9700 C



A-9717



A-9725



A-9737



A-9742/47/57



A-9715/17



A-9704



A-9758



A-9705



A-9765



A-9765 PAD



A-9765 R



A-9770



A-9770 MB



A-9715



A-9765

NUMBER	NAME OF PART	PRICE	NUMBER	NAME OF PART	PRICE
A-9700 B	1928-29 Choke rod assembly with sleeve and spring.	9.95	A-9737	1930-31 Accelerator return spring - tapered	2.10
A-9700 C	1930-31 Choke rod assembly with sleeve and spring	9.95	A-9737 AR	1928-30 Accelerator return spring, straight cylinder	2.10
A-9700 W	Choke kit for Weber carburetor	40.00	A-9742/47/57	1928-31 Spark and throttle rod control set 17", 10-1/2", 6"	15.00
A-9704	1928-31 Choke rod knob. Chrome	Disc.	A-9758	Spark rod sleeve, allows you to fine tune spark adjustment	9.00
A-9705	1928-31 Choke rod sleeve	1.10	A-9765 I	Rubber insert for accelerator foot rest	1.25
A-9709	1928-31 Choke rod spring	.50	A-9765 Pad	1928-31 Accelerator or foot rest pad	1.25 ea.
A-9715	1928-31 Lower choke rod grommet	.70	A-9765 R	1928-31 Accelerator foot rest post w/rubber insert	3.95
A-9717	1928-31 Upper choke rod grommet	.75	A-9770	1928-34 Accelerator foot rest base	3.75
A-9715/17	1928-31 Choke rod grommet set - 4 pc.	2.00	A-9770 MB	1928-31 Screws to mount A-9770	.40
A-9725	1928-31 Accelerator cap	3.25			

Generator

* Official Licensed Product
Official Aftermarket Accessories

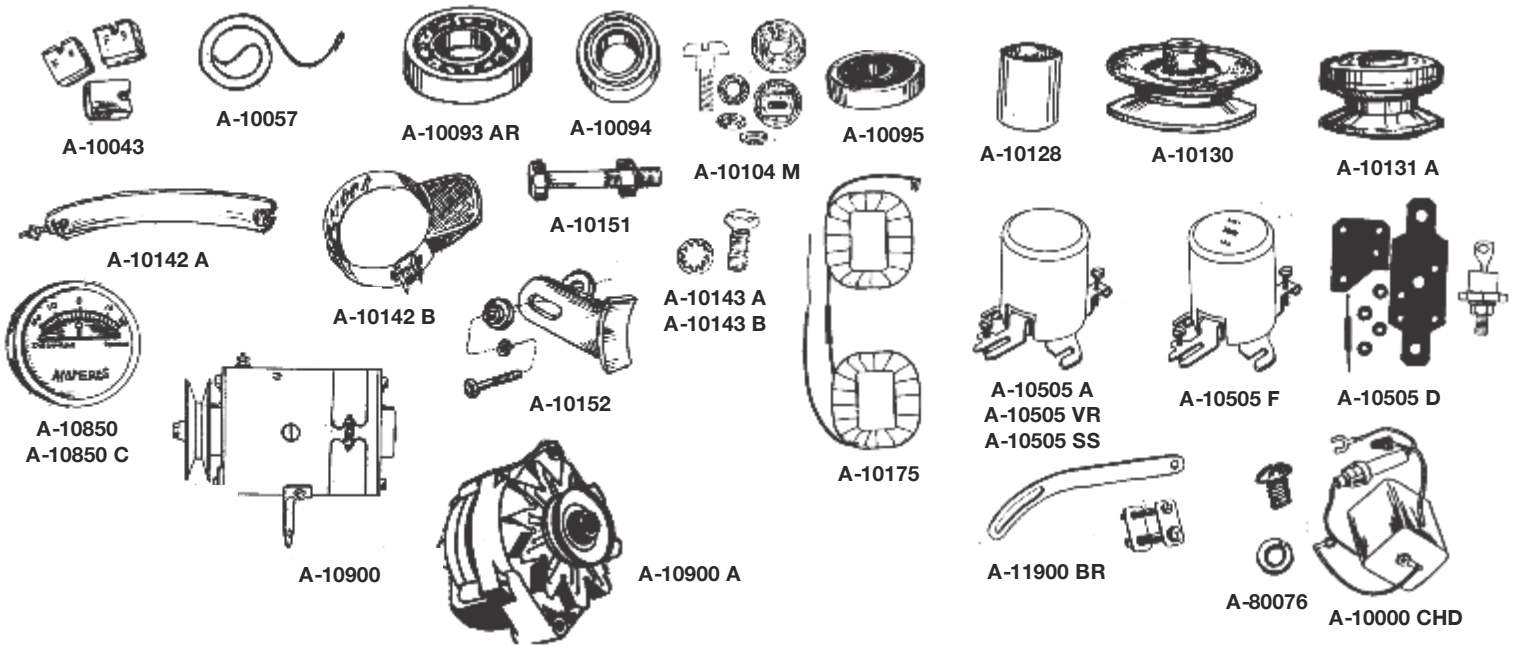

NUMBER	NAME OF PART	PRICE	NUMBER	NAME OF PART	PRICE
A-10000 CHD	Power converter (Heavy Duty) 6V to 12V for radio and CB, positive ground	99.95	A-10505 A	1928-31 Replacement type, cutout	24.00
A-10043	1929-31 Model A generator brushes	2.25	*A-10505 F	1928-31 Script cutout	Disc.
A-10057	1928-31 Ground & 3rd brush spring Right hand spring	.75	A-10505 D	1928-31 Diode kit for generator cutout Complete installation instructions.	5.95
A-10058	1928-31 Generator brush, left hand spring	.75	A-10505 SS	1928-31 generator cutout. Identical to original exterior dimensions, appearance & performance. Positive ground, solid state.	48.00
A-10093 AR	1928 Powerhouse generator bearing	6.15	A-10505 VR	Voltage regulator fits under new generator band. Electronically moves third brush to regulate simple three wire connections.	70.00
A-10094	1928-48 Generator bearing, pulley end	4.00	A-80076	1928-31 Cutout to generator bolt set	.60 set
A-10095	1928-30 Rear Plate Bearing	4.00	A-10850	Ammeter 20-0-20	8.25
A-10104 M	1929-31 Generator terminal post with bushing & washers	5.00	*A-10850 F	Ammeter 20-0-20 with Script	8.25
A-10128	1930-32 Generator end plate bushing	.95	A-10850 C	Ammeter, 30-0-30	8.25
A-10130	1930-31 Generator pulley	15.00	*A-10850 CF	Ammeter, 30-0-30 with Script	8.25
A-10131 A	Alternator pulley for Ford or Delco alternator with .670 shaft, small diameter	26.00	A-10900	Rebuilt generator (Exchange Only). Must have rebuildable core before shipment. Professional quality rebuild, less pulley	170.00
A-10142 A	1928-31 Generator band	4.00	A-10900 A	6-volt positive ground alternator. Complete with mounting brackets, change from generator to alternator in 10 minutes. 30-35 amp output. Single wire. Sold outright.	145.00
A-10142 B	1928-31 Generator band and cooler assy.	17.95	A-10900 AHD	New improved 6 volt positive ground 50 amp alternator. Kicks in faster and carries load better at lower rpm's. Comes with brackets	175.00
A-10143 A	1928-30 Generator pulley bolt set 1/4 x 28 x 8/16	.80	A-10900 B	12 volt negative ground alternator w/brackets	145.00
A-10143 B	1930-31 Generator pulley bolt set 5/16 x 24 x 1/2	.90	A-10900 BHD	New improved 12 volt negative ground 50 amp alternator with bracket. Kicks in faster and carries load.	175.00
A-10151	1928-31 Pivot bolt and nut	1.00	A-11900 BR	Alternator mounting & adjustment bracket.	20.00
A-10152	1928-31 Generator tension brace. Keeps belt tight	4.95			
A-10175	1928-31 Generator field coils	41.00			

Switch, Dash Panel, and Dash Lights

* Official Licensed Product
Official Mopar Performance

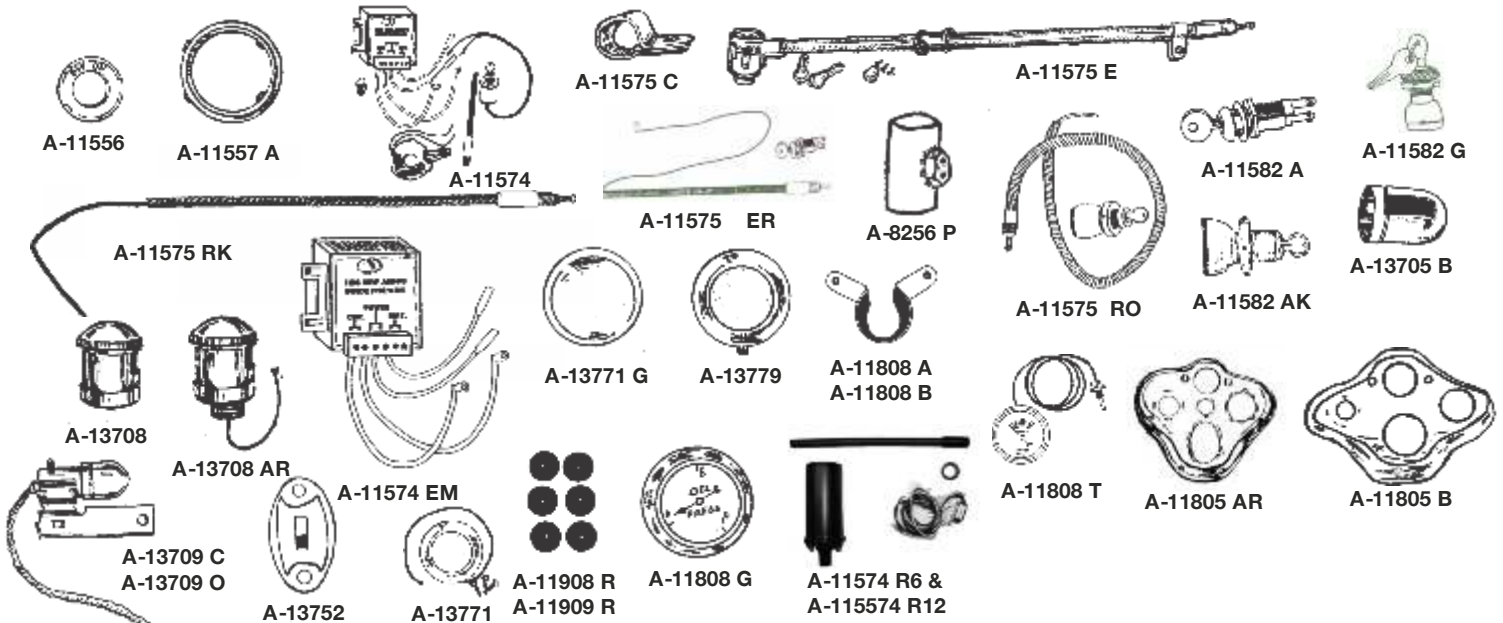

NUMBER	NAME OF PART	PRICE
A-11556	1928-31 On/Off switch plate	1.35
A-11557 A	1928-31 On/Off switch plate ring	2.60
*A-11557 B	Square and oval side data plate for original Briggs Stratton ignition cable	1.70
*A-11557 E	Round data plate for original electric lock ignition cable	1.40
A-11574	Modern transistor ignition system. No maintenance, increased spark resulting in smoother more powerful engine performance. Includes precision machined retractor potted magnetic pickup coil on new upper plate. Complete w/armored cable & new switch. Complete instructions. No change in original appearance.	245.00
A-11574 EM	Electric module for Nu-rex electronic ignition kit	125.00
A-11574 R6	Remund electronic ignition system. Solid state with 6 volt coil provided. 6 volt positive ground.	205.00
A-11575 C	Ignition cable clamp.	2.50
A-11575 E	Pop out ignition switch and cable, identical to original.	149.95
A-11575 ER	Replacement ignition switch and original style cable	25.50
A-11575 RE	Replacement ignition switch with 1/4" armored cable	22.50
A-11575 R12	12 volt negative ground electronic ignition with coil. Fits inside distributor. Remund	200.00
A-11575 RK	Pop out repair cable	15.95
A-11575 RO	1928-31 Look alike pop out switch & cable. A system without the problems associated with the original pop out switch	61.95
A-11582 A	Replacement; ignition switch w/keys	10.00
A-11582 AK	Replacement switch, USA mfg. Identical in appearance to the pop out switch. Can be used with armored cable.	48.95
A-11582 G	General replacement ignition switch, good quality	24.95
A-11582 U	Universal ignition switch key	2.00
A-13705 B	1930-31 Dash lamp cap	13.00
A-13708	Original 1928-30 dash light cover	13.00
A-13708 AR	1928-30 Dash light original push & turn type. Used w/oval panel	26.50
A-13709 C	1930-31 Dash light. Original design with switch, bracket & armored wire. Closed car.	27.00

NUMBER	NAME OF PART	PRICE
A-13709 O	1930-31 Dash light. Original design with switch, bracket & armored wire. Open car.	27.00
A-13752	Replacement dome light switch and mounting plate.	12.25
A-13771	1928-31 Dome light w/o switch	44.00
A-13771 CW	Wood for dome light (Coupe)	10.00
A-13771 SW	Wood for dome light (Sedan)	10.00
A-13771 G	Dome light round lens	7.50
A-13771 LED	1928-31 Dome light insert 12V LED	37.00
A-13779	1930-31 Deluxe coupe dome light with switch	53.00

Dash Rail

NUMBER	NAME OF PART	PRICE
A-11908 BT	1928-31 Stainless steel dash rail screws & nuts	1.95 set
A-11908 B	1928-31 Chrome dash rail screws & nuts	1.30 set
A-11908 R	1928-29 Dash rail rubber spacers, 7 pcs.	1.75 set
A-11909 R	1930-31 Dash rail rubber spacers, 5 pcs.	1.50 set
A-11952	1928-31 Side dash rail screws, holds Lower corners to cowl - 4 pcs	1.00 set

Dash Panel

NUMBER	NAME OF PART	PRICE
A-11805 AR	1928-30 Dash panel for oval speedometer	32.95
A-11805 B	1930-31 Dash panel for round speedometer	34.50
A-11806 BT	Oval speedometer dash panel screws, stainless steel	1.00
A-11807	1928-31 Dual gauge unpainted bracket	31.95
A-11807 BT	Round speedometer dash panel screws	1.00
A-11808 A	1928-30 Strap type gauge holder. Mounts on two lower screws of instrument panel	10.50 ea.
A-11808 B	1930-31 Strap type gauge holder. Mounts on two lower screws of instrument panel	10.50 ea.
A-11808 G	0-10 pound oil gauge	50.00 ea.
A-11808 T	1928-31 Rex-A-Co temperature gauge	70.00 ea.
A-8256 P	Temperature probe pipe for customers who do not want to drill & tap. Mounts A-11808 T probe in radiator hose.	15.00

Starter

* Official Licensed Product
Official Motor Components

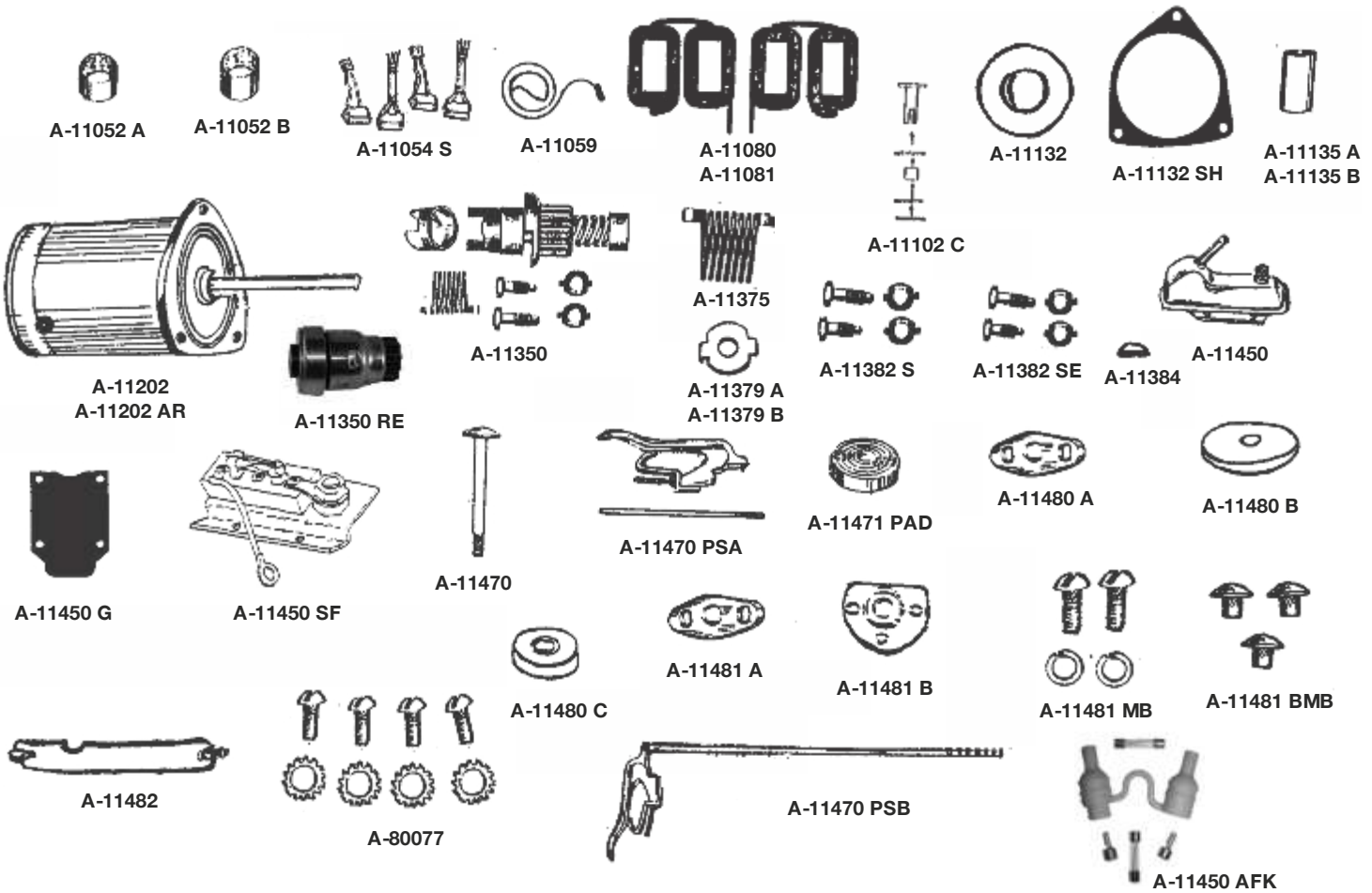

NUMBER	NAME OF PART	PRICE	NUMBER	NAME OF PART	PRICE
A-11002 MB	1928-31 Starter mounting bolts	1.50	A-11384	Starter Drive Key	.35
A-11005 D	1928-31 New starter armature - 5/8" shaft	99.00	A-11450	1928-31 Starter switch	19.00
A-11052 A	1928-31 1 1/16" OD Bushing, brush end	Disc.	A-80077	1928-31 Starter switch mounting screws and washers, 8 pc. set	.75
A-11052 B	1928-31 3/4" OD Bushing, brush end	1.25	A-11450 AFK	1928-31 Inline safety fuse mount	10.00
A-11054 S	1928-31 Starter brush set	4.25	A-11450 FU	Extra fuse for safety fuse mount. 30 amp	.35
A-11059	Starter brush spring, need 4	.40	A-11450 G	Starter switch gasket. Fits between switch & starter	.95 ea.
A-11080	Model A starter field coils. 6 volt.	45.00	A-11450 SF	1928-31 Safety fuse mount. Protect your model A against electrical shorts. Installs on starter switch. Comes with fuse.	9.75
A-11081	12 volt Model A starter field coil	45.00	A-11470	1928-31 Starter switch push rod	2.75
A-11102 C	Starter, field contact button terminal & insulators	6.00 set	A-11470 F	1928-31 Model A Upstart (pull start runs up steering column)	72.95
A-11132	Rear armature washer.	.50	A-11470 PSA	1928-31 Fulton pull start	Disc.
A-11132 SH	1928-31 Starter shim	.50 ea.	A-11470 PSB	1931 Fulton pull start assembly	Disc.
A-11135 A	1928-29 Starter bushing .688 O.D., drive end	2.65 ea.	A-11471 PAD	1928-31 Starter rod pad, page 43	1.25
A-11135 B	1929-31 Starter end plate bushing .753 O.D. drive end	1.75 ea.	A-11480 A	1928-30 Starter rod grommet	1.20
A-11202	Model A starter. Rebuilt. Must have old rebuildable core before shipment. Not all new parts - 6 volts	110.00	A-11480 B	Starter rod grommet for cars made from June to November 1930. Firewall will have a single 7/8" hole.	.95
A-11202 12V	1928-31 Model A starter rebuilt with new 12v field coils	150.00	A-11480 C	1930-31 Starter rod grommet	.95
A-11202 AR	Early 1928 starter (exchange)	120.00	A-11481 A	1928-30 Steel grommet cover	1.65
A-11350	1928-31 Starter drive	24.95	A-11481 B	1930-31 Steel grommet cover	3.00
A-11350 RE	1928-31 Modern day enclosed style starter drive	24.95	A-11481 MB	Round head screws & lock-washers used to mount oval shaped starter rod cover	.55
X-11350 T	Barrel drive compressor tool	16.00	A-11481 BMB	Set of three rivets used to mount round starter grommet cover	1.00
A-11375	1928-31 Bendix spring	7.00	A-11482	1928-31 Starter band	3.75
A-11379 B	Bendix spring bolt washer 3/8" NOS.	.75 ea.			
A-11379 A	Bendix spring bolt washer 5/16" NOS.	.75			
A-11382 S	1928-31 Bendix spring lock washers and bolts (4 pc. 3/8")	2.50 set			
A-11382 SE	1928-31 Bendix spring mounting bolts and lock washers - 4 pc. set 5/16"	2.75			

Distributor and Coil (Continued)

* Official Licensed Product
Ford Motor Company

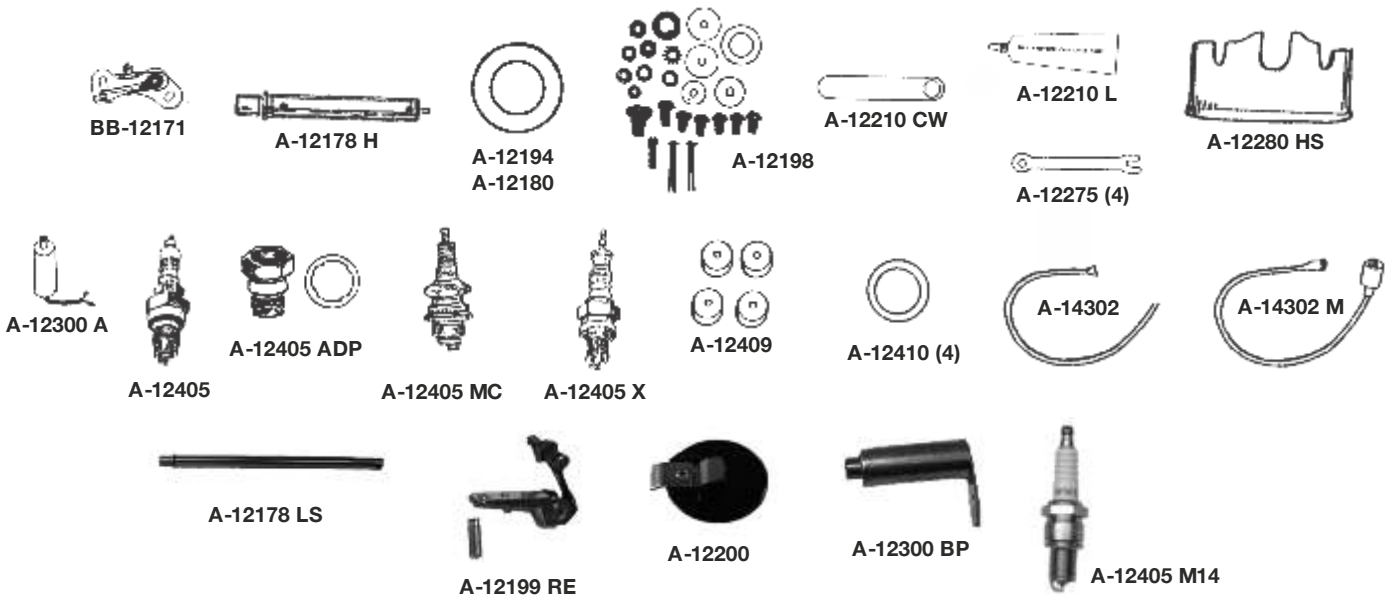

NUMBER	NAME OF PART	PRICE	NUMBER	NAME OF PART	PRICE
A-12160	1928-31 Distributor point block, USA Mfg.	4.75	A-12210 L	Distributor cam lubricant	7.50
BB-12171	Point set for A-12151 WC. Modern day upper plate	6.00	A-12211/13	Distributor cam screw & washer with hole	1.25
A-12178 H	Upper short distributor shaft w/oil hole in cam screw & shaft to oil bushing	10.50	A-12249	Intermediate distributor shaft	3.25
A-12178 LS	One piece distributor shafts	Disc.	A-12275	1928-31 Spark plug connectors (4) brass	1.45 set
A-12180	Upper distributor shaft thrust washer, steel .015 thick	.20 ea.	A-12275 C	Late 1931 bronze spark plug connectors	2.50
A-12194	Distributor shaft sleeve fiber washer, takes up end play, .045 thick	.20 ea.	A-12280 HS	1928-31 s/s Heat shield	4.00
A-12195/96	Distributor shaft sleeve & pin set	1.50 set	A-12300 A	Condenser for A-12151 WC	4.25
A-12196	Distributor shaft sleeve pin (Same as B-6551 P)	.25	A-12300 BP	Burnout resistant condenser	5.75
A-12198	1928-31 Dist. screw & small parts kits, set w/all necessary screws and rivets	4.75 set	A-12310	Washer that fits under original point post nut to prevent short of pigtail end	.20
*A-12199	1928-31 Ford Motorcraft points, original style. Script mfg. by Ford.	24.95	A-12370	1928-31 Automatic advance for distributor fits inside valve cover	175.00
A-12199 RE	1928-31 Points set - original type distributor	11.00 set	A-12405	Champion plugs W-16Y - 561	7.50 ea.
A-12200	Rotor	3.40	A-12405 ADP	Model A spark plug adapter for use with 14mm spark plugs or compression gauge	6.50 ea.
A-12210	Distributor shaft cam, USA mfg.	12.00	A-12405 ASET	Model A spark plug adapter - set of 4	24.95 set
A-12210 CW	Distributor cam wrench	1.25	A-12405 MC	Motorcraft plugs	3.75 ea.
A-12210 CX	Distributor cam timing tool - makes timing easy	9.75	A-12405 M14	14mm NGK Spark plug for use with adaptors. Medium heat range	2.75 ea.
			A-12405 X	Champion 3X plugs	28.95 ea.
			A-12409	Brass spark plug nuts	1.90
			A-12410	Copper spark plug gaskets (4)	2.50
			A-14302	Distributor hi-tension wire	1.50
			A-14302 M	Coil wire w/rubber boots	3.75
			B-12199	1932 Model B Distributor point set	24.00
			B-12300	1932 Model B Distributor Condenser	13.95

Lights

* Official Licensed Product
World's Most Versatile

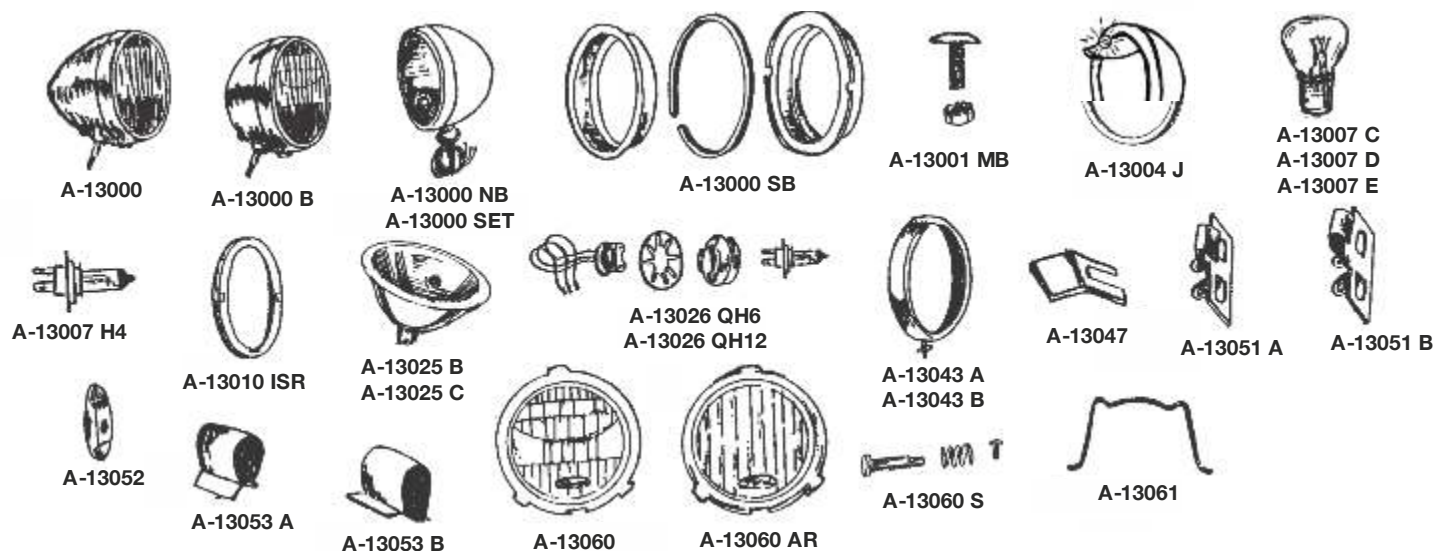

NUMBER	NAME OF PART	PRICE	NUMBER	NAME OF PART	PRICE
*A-13000	1928-29 Headlights, specify 1 or 2 bulbs	345.00 pr.	A-13027 QK12	Quartz halogen reflector kit with 12 volt halogen bulb kit installed	97.00
*A-13000 B	1930-31 Headlights, specify 1 or 2 bulbs	345.00 pr.	A-13027 QK6	Same as A-13027 QK12 only 6 volt	97.00
A-13000 NB	"Dietz" style Headlight. Chrome housings, includes rims, sockets, wiring & mounting studs & nuts.	50.00 pr.	A-13043 A	1928-29 Headlight rims stainless steel USA	36.50
A-13000 SET	Same as above with 12 volt sealed beam bulb	69.95	A-13043 B	1930-31 Headlight rims (stainless) USA	36.50 ea.
A-13000 SB	Sealed beam adapter (puts sealed beam behind original lens)	49.95	A-13047	Headlight T bar clip, protrudes at bottom of bucket	1.50 ea.
A-13001 MB	Stainless steel headlight shell mounting screws and nuts. Replaces rivets. Heads are smooth like rivets. (24 pc. set)	3.95 set	A-13051 A	1928-29 Inside hitch receptacle (holds latch to bucket)	1.50 ea.
A-13004 J	1928-31 Stainless steel headlight visor with red jewel	25.00 pr.	A-13051 B	1930-31 Inside hitch receptacle (holds latch to bucket)	1.50 ea.
A-13007 C	Headlight bulb 32-32 Cp-6 Volt	1.25	A-13052	1928-31 Headlight latch T-bar stainless steel	1.30 ea.
A-13007 D	Headlight bulb 50-32-Cp	1.45	A-13053 A	1928-29 Headlight bucket top retainer clips. Holds top of rim to bucket.	2.25 ea.
A-13007 E	Headlight bulb 12 volt 32-32	1.45	A-13053 B	1930-32 Holds top of rim to bucket.	1.75 ea.
A-13007 H4	Headlight Bulb 12V 55/60 Halogen bulb (for street rods)	4.50	*A-13060	1929-31 Ford script headlight lens USA	21.00 ea.
A-13007 H4 6V	6 volt halogen bulb	13.00	*A-13060 AR	1928 Fluted headlight lens	21.00
A-13007 HB5	New style halogen replacement bulb 12V black plastic base	6.50	A-13060 S	1928-31 Headlight latch repair kit. Post, springs and rivets.	2.75
A-13010 AIR	Inner steel ring on 1928-29 that holds reflector in place	12.50	A-13061	1928-31 Headlight lens retainer clip set. 6 pc. set for both lights.	2.25 set
A-13010 ISR	Inner steel ring on 1930-31 that holds reflector in place	12.50 ea.			
A-13025 B	2 Bulb headlight reflector	30.00 ea.			
A-13025 C	1 Bulb headlight reflector	30.00 ea.			
A-13026 QH12	Quartz halogen headlight adapter kit. Includes 2 halogen bulbs, 2 socket adapters, 2 press nuts, (2) 3 wire plugs, and complete instructions to fit reflector - 12 Volt	36.00			
A-13026 QH6	Same as above, 6 Volt	48.00			

Lights (continued)

* Official Licensed Product
 © 1997-2000 by *Wagner Electric*



A-13066 C
A-13066 NEO



A-13075 AR

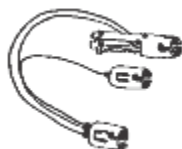

A-13075 B

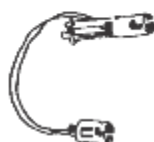

A-13075 B-1



A-13075 C

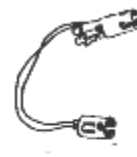

A-13075 C-1

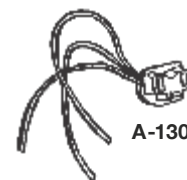

A-13075 SB



B-130075 B



A-13101/2A



A-13101/AS



A-13101/2B

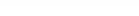

A-13101/BS



A-13114 A
A-13114 B

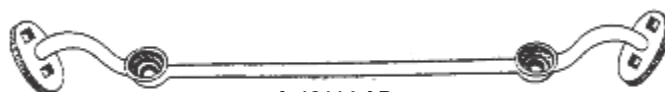

A-13114 AD
A-13114 AE



A-13115
A-13115 SS



A-13116



A-13117



A-13118 A
A-13118 B



A-14578 S

NUMBER	NAME OF PART	PRICE	NUMBER	NAME OF PART	PRICE
A-13066 C	1928-31 Cork headlight reflector gaskets	2.00	A-13114 A	1928-29 Headlight bar pads	1.45 pr.
A-13066 NEO	1928-31 Rubber headlight reflector gaskets. Neoprene will not break.	2.50 pr.	A-13114 AD	1928-29 Dropped headlight bar, polished stainless	165.00
A-13075 AR	1928 Headlight socket (original type)	8.00 ea.	A-13114 AE	1930-31 Dropped headlight bar, polished stainless	165.00
A-13075 B	1928-29 Headlight 2-bulb socket	8.75 ea.	A-13114 B	1930-31 Headlight bar pads	1.45 pr.
A-13075 B-1	1928-29 Headlight 1-bulb socket	7.50 ea.	A-13115	1928-31 Headlight bar bolts, nuts and lock-washers. Black oxide	3.00
A-13075 C	1930-31 Headlight 2-bulb socket	8.75 ea.	A-13115 SS	Stainless steel headlight bar bolts & lock-washers	8.50 set
A-13075 C-1	1930-31 Headlight 1-bulb socket	8.00 ea.	A-13116	1928-31 Headlight mounting nuts and lock-washers. Cadmium plated.	1.10
A-13075 HD	Heavy duty halogen headlight & flasher plug	5.70	A-13116 BT	Headlight bucket bolts used to mount bucket to bar	5.95 ea.
A-13075 SB	Socket for sealed beam lights & flasher	2.50	A-13116 RS	Headlight bolt retainer strap	2.75
B-130075 B	1928-55 6 volt sealed beam bulb	13.50 ea.	A-13117	Late 1928-31 Headlight base socket. For mounting conduit to headlight.	5.60 ea.
A-13101/2A	1928-29 Headlight focus spring and screw set	1.15	A-13118 A	1928 Headlight socket that fits under base plate 1/2" diameter	3.50
A-13101 AS	1928-29 Headlight focus stainless steel screws	.60	A-13118 B	1929-31 same as above with 9/16" diameter	3.10
A-13101/2B	1930-31 Headlight focus spring and screw set	1.15	A-14578 S	1928-31 Headlight & horn conduit set	8.50
A-13101 BS	1930-32 Headlight focus stainless steel screws	.60			

Cowl Lights

* Official Licensed Product
Official Aftermarket

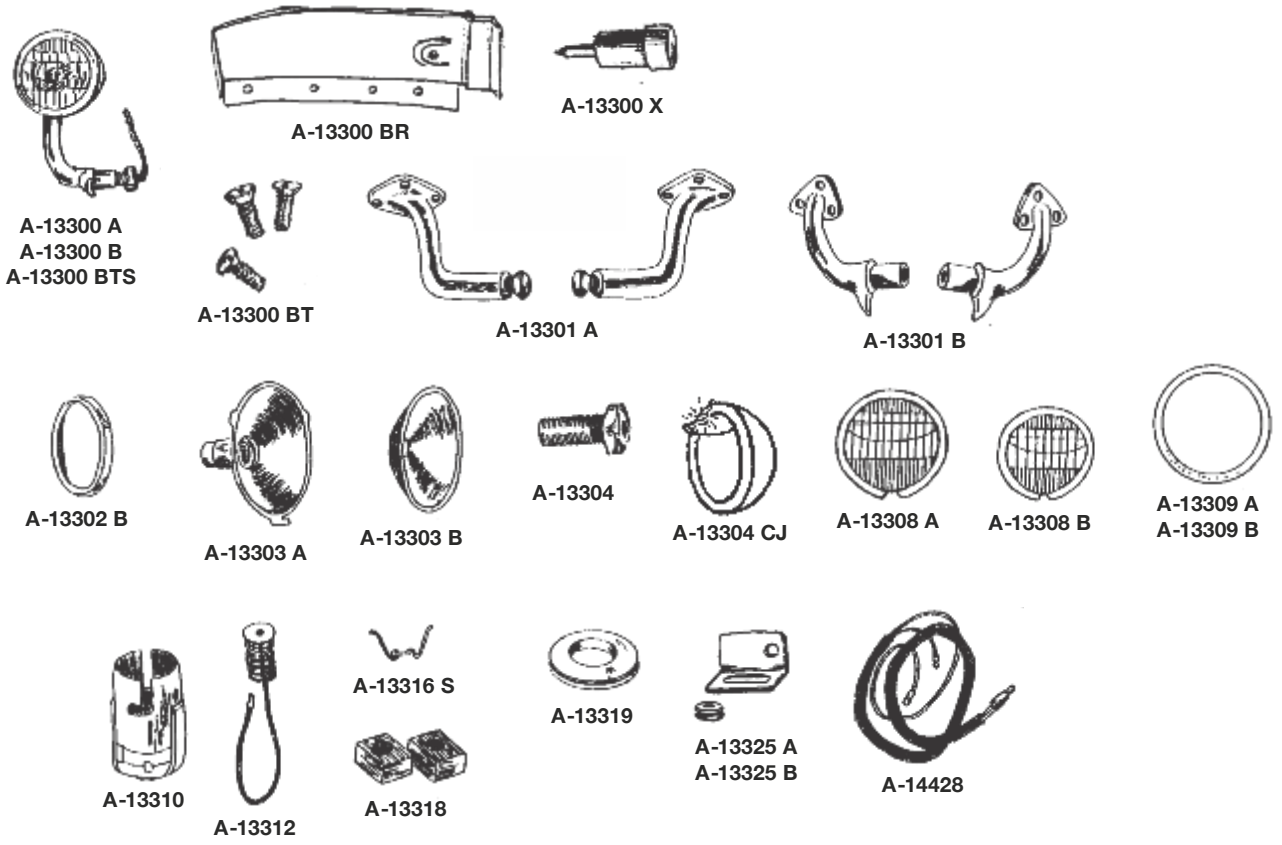

NUMBER	NAME OF PART	PRICE	NUMBER	NAME OF PART	PRICE
A-13300 A	1928-29 Stainless Steel cowl lights	175.00 pr.	A-13309 A	1928-29 Cowl light gasket	1.15 pr.
A-13300 ATS	1928-29 Cowl light with turn signal style reflector 12V	193.00	A-13309 B	1930-31 Cowl light gasket	1.00 pr.
A-13300 B	1930-31 Cowl lights complete w/arms	140.00 pr.	A-13310	1930-31 Cowl light socket	4.00 ea.
A-13300 BTS	1930-31 Cowl light with turn signal style reflector. 12V	163.00	A-13312	1928-34 Cowl light pigtaills	3.75 pr.
A-13300 BR	Bracket that goes inside 1928-29 cowl to mount cowl lights.	42.50	A-13316 S	1930-31 Cowl light lens retainer	1.35 set
A-13300 BT	1930-32 Cowl light screw set	1.95 set	A-13318	1930-31 Cowl light mounting spacer blocks. Keep cowl lights from flexing.	4.25 pr.
A-13300 X	Cowl light marking tool used to locate point to drill arm hole.	3.50	A-13319	1928-29 Cowl light grommet	1.80 ea.
A-13301 A	1928-29 Cowl light arms	105.00 pr.	A-13325 A	1928-29 Cowl light wire and wiper vacuum line support bracket and grommet	2.25 ea.
A-13301 B	1930-31 Cowl light arms	105.00 pr.	A-13325 B	1930-31 Cowl light wire and wiper vacuum line support bracket and grommet	2.25 ea.
A-13302 A	1928-29 Cowl light rim	14.25	A-13350 12V	Flasher, Turn signal 12V	3.50 ea.
A-13302 B	1930-31 Cowl light rim	14.25	A-13355 LED	Load resistor, 50 watt simulates the load of an incandescent bulb, solves turn signal problem	12.00 ea.
A-13303 A	1928-29 Cowl light reflector	15.25 ea.	A-13465 CL6V	21/3cp 6 volt bulb for cowl lights with turn signal	1.00 ea.
A-13303 B	1930-31 Cowl light reflector	10.75 ea.	A-13465 CL12V	Same as A-13465 CL6V only 12 volt	1.00 ea.
A-13304	Cowl light mounting bolt	1.00 ea.	A-14428	1928-31 Cowl light extension wire	9.75
A-13304 CJ	1930-31 Stainless steel cowl light visor with jewel insert.	22.50 pr.			
A-13308 A	1928-29 Cowl light lens	7.00 ea.			
A-13308 B	1930-31 Cowl light lens	5.00 ea.			
A-13308 DA	1930-31 Amber Cowl light lens	5.95			

License Plates, License Plate Frames, and Clips

* Official Licensed Product
Ford Motor Company

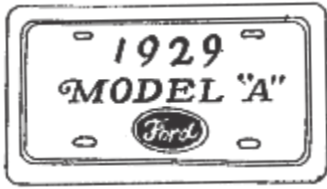

A-13147 B



A-13408 & A-13408 A
&
A-13410 & A-13411 R



A-13146-29



A-13145 CAD
A-13145 SS



A-13146 ACC

NUMBER	NAME OF PART	PRICE	NUMBER	NAME OF PART	PRICE
	Blue & red imprint on white background.				
A-13147 A	1928 License plate	9.00 ea.	A-13145 A	1928-29 Original ribbed design license plate clips	7.50 set
A-13147 B	1929 License plate	9.00 ea.	A-13145 CAD	License plate clips - black	4.50
A-13147 C	1930 License plate	9.00 ea.	A-13145 SS	Stainless steel license plate clips	8.95
A-13147 D	1931 License plate	9.00 ea.	*A-13146-28	1928 License plate frame	7.50 ea.
A-13408	Blue license plate reflector bolts.	1.00 pr.	*A-13146-29	1929 License plate frame	7.50 ea.
A-13409 A	Amber license plate reflector bolts.	1.00 pr.	*A-13146-30	1930 License plate frame	7.50 ea.
A-13410	Green license plate reflector bolts.	1.00 pr.	*A-13146-31	1931 License plate frame	7.50 ea.
A-13411 R	Red license plate reflector bolts.	1.00 pr.	A-13146 ACC	1928-31 Accessory license plate bolts. Fits any car with slotted 1/4" bracket. Brass with nickel finish. set of (2)	4.50 pr.
B-13401 SS	License frame back plate - stainless steel stiffens plate to prevent damage - louvered	9.95 ea.			

Tail Lights

1928 DRUM TAIL LIGHT

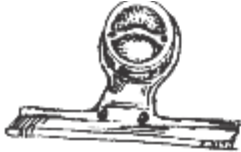

A-13605 L
A-13605 R



A-13440 AR

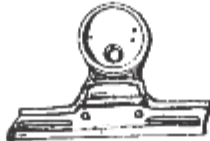

A-13406 AR



A-13410 A



A-13441 BT



A-13442 AR



A-13445 AR

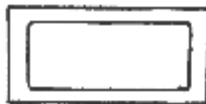

A-13447 AR



A-13450 AR



A-13461 AR

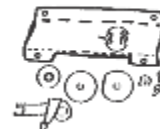

A-13406 DP



A-13409



A-13473 AI



A-13471 AR

NUMBER	NAME OF PART	PRICE	NUMBER	NAME OF PART	PRICE
A-13605 CBL	1928 Commercial Left drum tail light, black	117.00	A-13461 AR	1928 Drum tail light gasket	.60
A-13605 CBR	1928 Commercial Right drum tail light, black	119.00	A-13406 DP	Drum tail light dividing plate kit	21.50
A-13605 L	1928 Left drum tail light, complete, nickel	127.00	A-13409	Ext. wire for drum tail light	6.00
A-13605 R	1928 Right drum tail light, complete, nickel	127.00	A-13471 AR	Tail light Bracket 1928 Rdstr. & Coupe, Left Side	17.95
A-13440 AR	1928 Drum tail light body	27.50	A-13471 BR	Tail light Bracket 1928 Rdstr. & Coupe, Right Side	23.00
A-13406 AR	1928 Drum tail light bracket	29.95	A-13473 AL	Tail light bracket 1928 Sedan and Touring left hand.	25.50
A-13410 A	1928-29 Drum tail light socket	43.00	A-13473 AR	Tail light bracket 1928 Sedan and Touring right hand.	25.50
A-13441 BT	1928 Lens retainer sleeve set	4.95	A-14595	Drum tail light wire clips - clip onto cast iron bracket	2.90 pr.
A-13442 AR	Stop face plate	5.95			
A-13445 AR	1928 White license lens	8.50			
A-13447 AR	Drum tail light license plate lens gasket	.55			
A-13450 AR	1928 Ruby red lens	7.75			

Tail Lights (continued)

* Official Licensed Product
World's Most Versatile

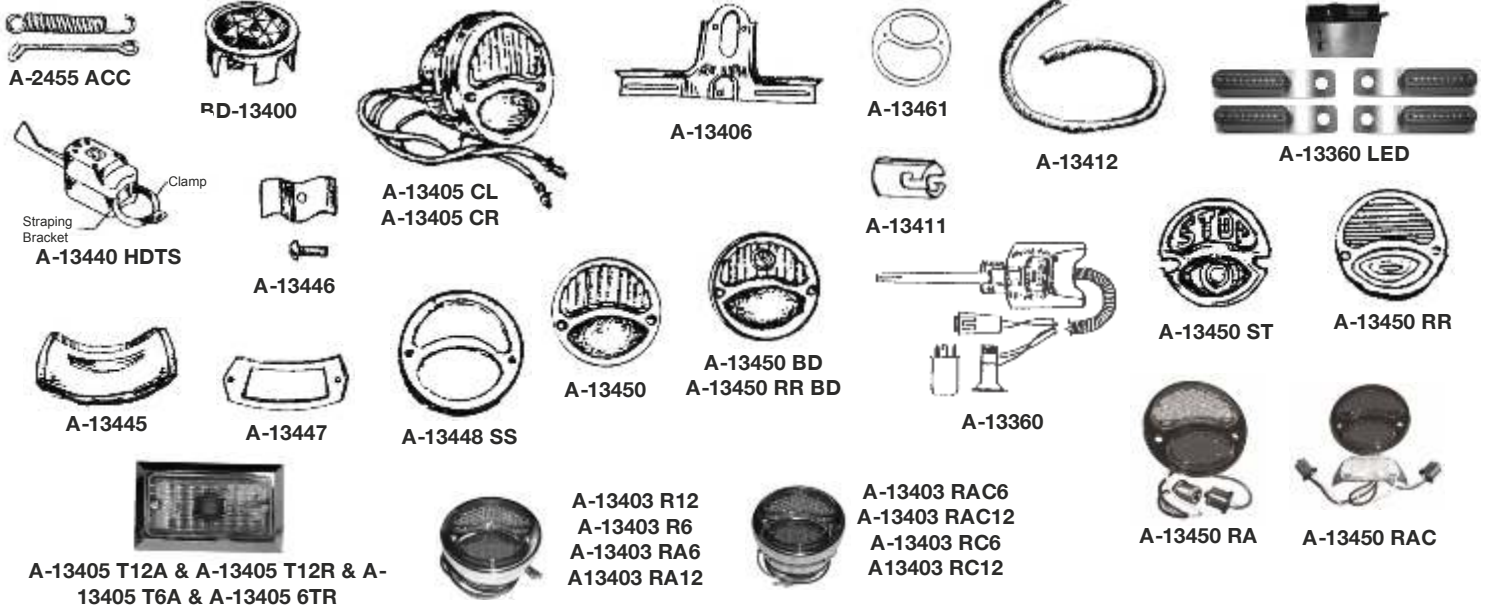

NUMBER	NAME OF PART	PRICE	NUMBER	NAME OF PART	PRICE
A-2455 ACC	1928-31 Accessory brake pedal anti rattler and return spring	5.25	A-13405 T12A	Turn signal light with amber lens and chrome bezel. 12 volt.	19.95
A-13312 T	Turn signal beeper, 6 or 12 volt	5.95	A-13405 T12R	Turn signal light with red lens and chrome bezel. 12 volt.	19.95
A-13350 6V	Turn signal flasher, 6 volt	4.95	A-13405 T6A	Turn signal light with amber lens and chrome bezel. 6 volt.	20.95
A-13350 12V	Turn signal flasher, 12 volt	3.50	A-13405 T6R	Turn signal light with red lens and chrome bezel. 6 volt.	20.95
A-13350 LED12	Flasher with ground wire for use with LED bulbs or small incandescent bulbs, 12 volt	12.00	A-13406	License plate bracket. Identical to original	5.95 ea.
A-13355 LED	Load resistor 50 watt, 6 OHM simulates the load of an incandescent bulb, solves turn signal problems (Hyper flasher, no flashing burnt out bulb indicator. 1 per side)	12.00	A-13406 SS	Same as above but polished stainless steel	12.95 ea.
A-13360	Turn signal kit with modified switch & wire to use existing tail light bulbs, cowl light bulbs or headlight park bulbs. Use with existing wiring	140.00	A-13411	1929-32 tail light socket	1.00
A-13360 LED	1928-31 LED turn signals and controller. Has separate lights that mount between bumper bars. Complete kit	199.95	A-13412	Tail light loom, protects tail light wires.	1.25
BD-13400	Glass Blue Dot Lens w/ring. Insert in your tail light. Blue dots are unlawful in S.C. and possibly other states.	4.50 ea.	A-13412 DC	1909-31 double contact tail light socket	7.10
A-13403 R12	SS Tail light housing assembly with LED lens. All red, right hand, 12 volt	40.00	A-13412 RP	Double contact pigtail, upgrade your sockets for turn signals	2.00 ea.
A-13403 R6	SS Tail light housing assembly with LED lens. All red, right hand, 6 volt	42.00	A-13440 HDTS	Heavy duty turn signal switch w/pilot light & 4 way hazard switch	24.95
A-13403 RA12	SS Tail light housing assembly with LED lens. Red/Amber, right hand, 12 volt	42.00	A-13445	License plate lens	3.75
A-13403 RA6	SS Tail light housing assembly with LED lens. Red/Amber, right hand, 6 volt	45.00	A-13446	License plate lens retainer	1.20
A-13403 RAC12	SS Tail light housing assembly with LED lens. Red/Amber, left hand, 12 volt	50.00	A-13447	License lens gasket	.50
A-13403 RAC6	SS Tail light housing assembly with LED lens. Red/Amber, left hand, 6 volt	52.00	A-13448 BT	1929-31 Tail light and rim screws, stainless	.55 pr.
A-13403 RC12	SS Tail light housing assembly with LED lens. All red, left hand, 12 volt	48.00	A-13448 SS	Tail light rim, polished stainless	6.25
A-13403 RC6	SS Tail light housing assembly with LED lens. All red, left hand, 6 volt	50.00	A-13450	Half amber tail light lens	6.00
A-13404 12V	Third brake light - 12 volt LED	59.95	A-13450 BD	Half Amber tail light lens w/blue dot. Blue dots are unlawful in South Carolina and possibly other states	17.00
A-13404 6V	Third brake light - 6 volt LED	59.95	A-13450 R6	1928-31 LED Tail light lens, 6 volt. Right hand red.	28.00
A-13405 CR	Stainless steel R/H tail light, no license plate lens, 1929-31	38.00 ea.	A-13450 R12	1928-31 LED Tail light lens, 12 volt. Right hand red.	26.00
A-13405 CL	Stainless steel L/H tail light, with license plate lens, 1929-31	38.00 ea.	A-13450 RA6	1928-31 LED Tail light lens, 6 volt. Right hand, red/amber	30.50
			A-13450 RA12	1928-31 LED Tail light lens, Red/Amber, right hand, 12 volt	28.00
			A-13450 RAC6	1928-31 LED Tail light lens, 6 volt. Left hand, red/amber	39.00
			A-13450 RAC12	1928-31 LED Tail light lens, Red/Amber/Clear, left hand, 12 volt	36.50
			A-13450 RC6	1928-31 LED Tail light lens, 6 volt. Left hand, red/clear	36.50
			A-13450 RC12	1928-31 LED Tail light lens, 12 volt. Left hand, red/clear	35.00
			A-13450 RR	1929-31 All red tail light lens	6.00 ea.
			A-13450 RR BD	1928-31 solid red lens with blue dot installed	17.00
			A-13450 ST	1928-31 Half Amber with Stop moulded in glass.	9.75

Tail Lights *(continued)*

* Official Licensed Product
Official Aftermarket Accessories

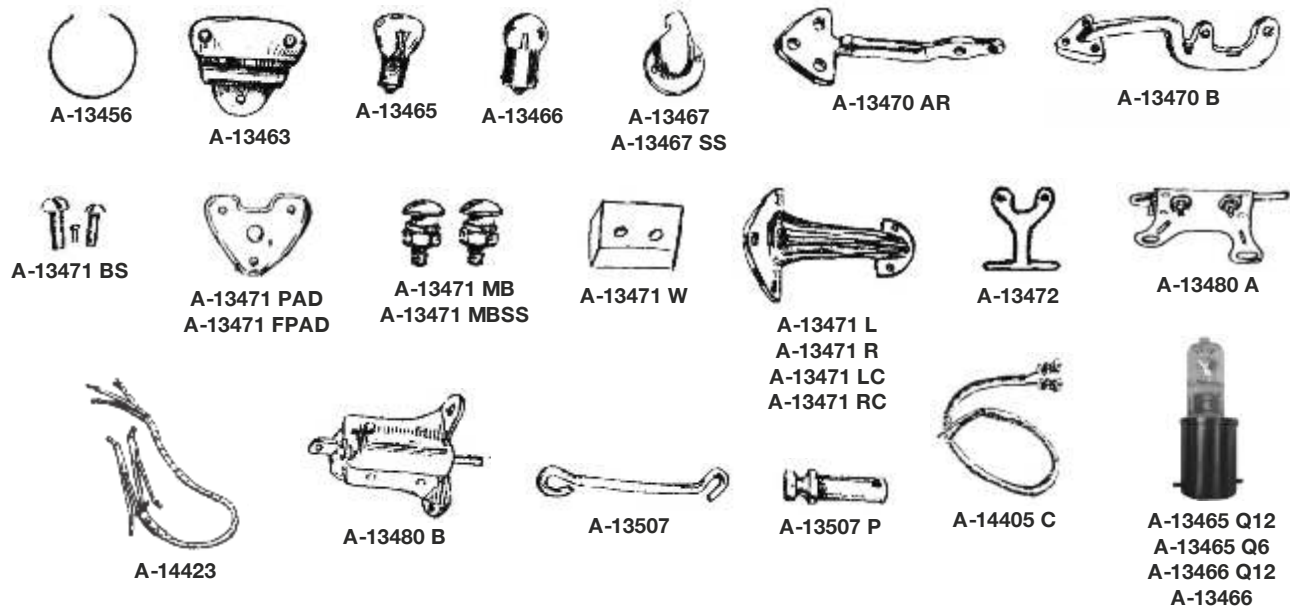

NUMBER	NAME OF PART	PRICE	NUMBER	NAME OF PART	PRICE
A-13456	Tail light lens lock ring	.95	A-13471 R	Tail light bracket, right hand	8.95
A-13461	Tail light lens gasket	.50	A-13471 RC	Tail light bracket, right hand chrome	11.50
A-13463	Tail light reinforced plate	3.25	A-13471 L	Tail light bracket, left hand	8.95
A-13465	Stop light bulb, 6 volt	.95	A-13471 LC	Tail light bracket, left hand chrome	11.50
A-13465 A	6 volt, 21-3 cp, pins straight across, double contact	1.80	A-13471 BS	1929-31 Tail light screws. Set of 6, for mounting lens door and license lens	1.10
A-13465 B	6 volt, 21-3 cp, pins staggered, double contact	1.00	A-13471 PAD	Rubber tail light pad, moulded type	2.00
A-13465 12V	Stop light bulb, 12 volt, single element	.85	A-13471 FPAD	Flat tail light bracket pad - cannot be seen	1.75
A-13465 BHP	6V 50/14 cp, double contact stop light bulb Staggered pins	1.25	A-13471 W	Tail light bracket wood block	3.50
A-13465 CL6V	1928-29 21/3cp 6 volt bulb for replacement cowl light A-13000 ATS with turn signal	1.00 ea.	A-13471 MB	Special large head tail light bracket mounting bolts and nuts	1.75 pkg.
A-13465 CL12V	Same as A-13465 CL 6V only 12 volt	1.00 ea.	A-13471 MBSS	Stainless steel tail light bracket mounting bolts	3.50
A-13465 HP12	12V Double filament bulb for turn signals	1.25	A-13472	1930-31 Tail light bracket, Panel Delivery, Station Wagon, DLX. Delivery, Express Body, Service Car	9.25
A-13466	6V 3 cp Tail light, parking light, & cowl light bulb	.85 ea.	A-13480 A	1928-29 Brake light switch, bolts on transmission.	7.25
A-13466 12V	12V 4 cp Tail light, parking light, & cowl light bulb	.85	A-13480 B	1930-31 Brake light switch bolts on cross member. Fits some late 1929's.	5.25
A-13466 HD	6V Heavy Duty 9 cp tail light, parking light, & cowl light bulb	1.00	A-13507	1928-29 Tail light link	1.50
A-13466 HD12	12V Heavy Duty 10 cp tail light, parking light, & cowl light bulb	1.00	A-13507 P	1928-29 Tail light link clevis pin	1.25
A-13465 Q12	Stop light bulb, Quartz Halogen, 12V 50W	15.00	A-14405 C	Tail light pigtails, w/loom cover	5.25 set
A-13465 Q6	Stop light bulb, Quarts Halogen, 12V 50W	15.00	A-14423	Tail light crossover wire. Needed when right tail light is added.	10.25
A-13466 Q12	Tail, cowl, dash, park light, Quartz Halogen 12V 20W	15.00			
A-13466 Q6	Tail, cowl, dash, park light Quartz Halogen 6V 20W	15.00			
A-13467	Pickup tail light shield	6.25			
A-13467 SS	PU Tail light shield in stainless	8.95			
A-13470 AR	1928-29 Pickup tail light bracket, cast iron	17.00			
A-13470 B	1929-31 Pickup tail light bracket, cast iron.	9.50			

Horns

* Official Licensed Product
Official Licensed Product



A-13802



A-13802 RG
 A-13802 RG12



A-13802 RED



A-13804



A-13805

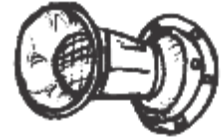

A-13807 B

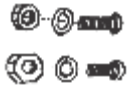

A-13808 BT

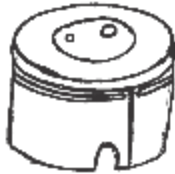

A-13809 SR



A-13809 SC



A-13811



A-13812



A-13815



A-13817 S



A-13819



A-13820



A-13821



A-13830



A-13840

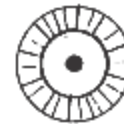

A-13908



A-13909



A-13912



A-13916



A-13802 EC12

NUMBER	NAME OF PART	PRICE	NUMBER	NAME OF PART	PRICE
A-13802	Horn plate with rivets	.95	A-13809 SR	Die stamped, 2 piece, horn cover, "SA." stamped on cover. Authentic for later "A's"	9.00
A-13802 EC12	Economy import AH-000-GA horn, 12 volt	24.95	A-13811	Horn diaphragm. The part that makes the horn sound correctly. Made as original spring steel.	5.75
*A-13802 RG	A new original Sparton horn identical in every way to the original Horn. Complete with plate and mounting bracket. High quality USA mfr.	273.00	A-13812	Horn diaphragm gasket	1.50 pr.
*A-13802 RG12	Same as above except 12V	265.00	A-13815	Horn brush holding assembly, 5 pc. set	6.25
A-13802 RED	Voltage reducer, used to reduce 12v to 6v for 6v horns	21.95	A-13817 S	Pair brushes and springs for horn motor, 4 pc. set	1.95
A-13804	Horn adj. screw w/serrated edge	1.20	A-13819	1928-31 Horn terminals inside horn	5.50 pr.
A-13805	Horn bracket	3.00	A-13820	1928-31 6V Horn relay. Fits under horn cover. Helps eliminate horn motor drag & failure.	15.00
A-13807 B	Horn bell, flange with screen	70.00	A-13821	1928-31 Horn terminal insulator	4.95
A-13808 BT	Horn bell flange screws, 6 pc. set	2.60	A-13830	Horn brush tension spring	Disc.
A-13809	Die stamped, 2 piece, horn cover with "Adjust" stamped on top, can be used 1928-31	9.50	A-13840	Horn bell screen	1.75
*A-13809 AR	Die stamped horn cover "Ford, Sparton, & Adjust" stamped on cover, correct for early 1928	10.95	A-13908	Horn motor ratchet	1.75
A-13809 SC	Horn cover screw	.50	A-13909	Horn motor tension spring	2.85
A-13802 BH	12 volt electric bull horn, red	49.95	A-13912	Horn adjusting bar	3.25
10W	Wolf Whistle connects to intake. Works off vacuum	45.00	A-13916	Horn adjusting bar spring	.50

Wiring

* Official Licensed Product
 Official Licensed Product
 Official Licensed Product

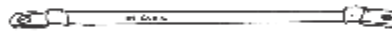
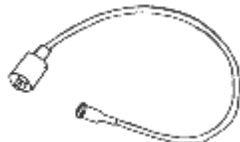
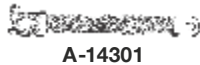

NUMBER	NAME OF PART	PRICE
A-11646	1928-31 Headlight wiring harness, one bulb cowl light type	48.00
A-11646 T	Headlight wiring harness with turn signals. One bulb.	138.00
A-11647	1928-31 Headlight wiring harness, two bulb park light type	50.00
A-11647 T	Headlight wiring harness with turn signals. Two bulb.	145.00
B-11655 S	Light switch selector housing	17.75
A-13312 T	Turn signal beeper. Put in your turn signal wiring to alert you when turn signal is activated. 6 or 12 volt.	5.95
A-13350 6V	Flasher, directional light, 6 volt	4.95
A-14300 B	1928-31 Original type battery cable, braided cover as original with correct clamp	14.50
A-14300 BRCKT	Bracket used to mount A-14300 D under the hood. Bracket mounts to bottom starter mounting bolt	7.50
A-14300 C	TERMINAL MOUNT BATTERY DISCONNECT SWITCH. Mounts to battery post. Turn 1/4 turn to cut power or remove knob to discourage theft.	7.95
A-14300 D	BATTERY DISCONNECT SWITCH. May be used with 6 or 12 volts. Put in main battery wire to disconnect power. Mounts on firewall on floorboard.	24.50
A-14300 E	Electrical switch disconnect cable. One end goes to switch, the other end to the starter.	8.50
A-14300 MB	Bolt. Battery cable to frame	.60 ea.
A-14301	1928-31 Replacement battery ground cable	8.50
A-14301 B	Replacement battery clamp, bolt and nut	.50
A-14301 BR	1928-30 Original design ground strap. Flat copper trips	16.75
A-14301 BT	Bolt. Special HD cable to frame (used from 1928 till March 1930)	3.25
A-14302	1928-31 Coil to dist. wire original design hi tension, black with brass ends	1.50
A-14302 M	Coil Wire w/rubber boots	3.75

NUMBER	NAME OF PART	PRICE
A-14305	1928-31 Coil to terminal wire, low voltage	2.25
A-14350 A	Wiring diagram for cars with cowl lights	7.00
A-14350 B	Wiring diagram for cars without cowl lights	7.00
A-14350 WD	Double sided wiring diagram - color coded one side for cars with cowl lights the other for cars without cowl lights	6.00
A-14401 B	1928-31 Instrument panel wire (replacement type)	Disc.
A-14401 BH	1928-31 Heavy duty instrument panel wire as original with braided cover	8.95
A-14401/6	1928-31 Engine wiring set-includes dash harness, generator and starter harness, coil to terminal box wire, coil to distributor cap wire, brass terminals and 4 brass spark plug straps (switch and distributor cable not included)	21.00 set
A-14405 AW	Armored wire. Used w/spotlight. 16 gauge	1.25 ft
A-14405 BG	Black with green tracer, 14 gauge	.65 ft.
A-14405 BL	Solid black, 14 gauge	.65 ft.
A-14405 BR	Black with red tracer, 14 gauge	.65 ft.
A-14405 BY	Black with yellow tracer, 14 gauge	.65 ft.
A-14405 C	Taillight Pigtails	5.25 set
A-14405 W	Yellow woven wire w/black tracer. Sold by the foot. 14 gauge	.65 ft
A-14405 RB	Yellow with red and black tracer, 14 gauge	.65 ft.
A-14405 WB	Yellow with red tracer, 14 gauge	.65 ft.

Wiring (Continued)

* Official Licensed Product
Official Aftermarket Accessories

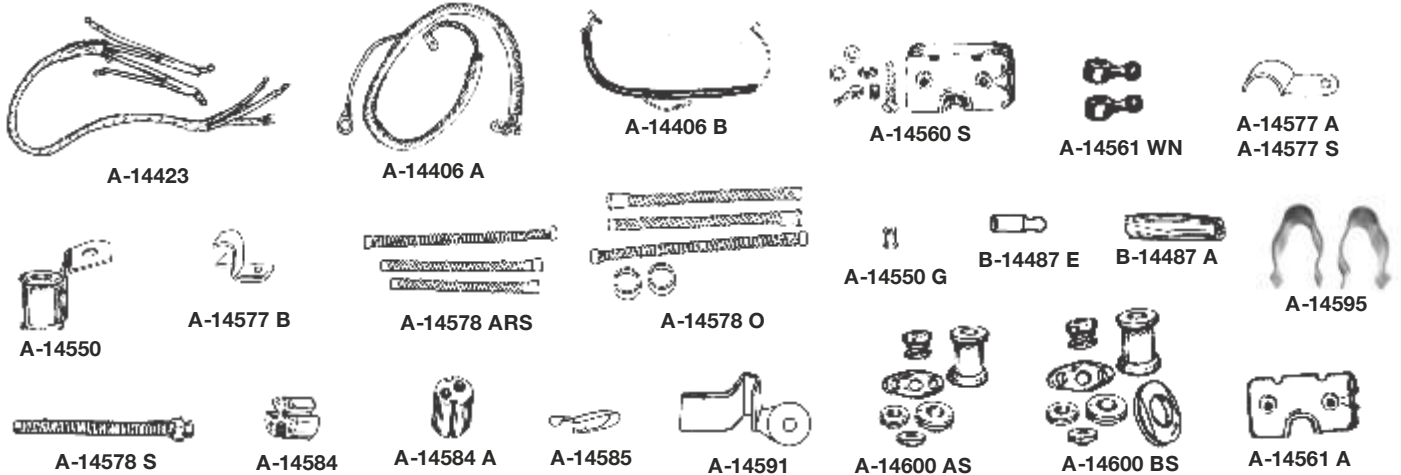

NUMBER	NAME OF PART	PRICE	NUMBER	NAME OF PART	PRICE
A-14406 A	1928-31 Starter and generator wire	8.50	A-14577 B	1928-30 Wire clip on firewall for starter/generator wire with steel conduit	1.70
A-14406 B	1928-29 Starter and generator wire in steel conduit	14.95	A-14577 S	1930-31 Speedometer cable clip on firewall	1.25 ea.
A-14423	1928-31 Tail lamp crossover wire, used when adding right tail light	10.25	A-14578 ARS	1928 Headlight & horn conduit set	18.00
B-14487 A	Wire connector - used to connect one light harness wire to another, set of 10	3.75 set	A-14578 F	1928-31 Headlight conduit ferrule	2.50
B-14487 CR	1928-31 Replacement bullet ends - 10 pcs Crimp style	2.50 set	A-14578-O	9/16" 1929-34 Headlight conduit set	32.00
B-14487 E	Replacement bullet ends for wire connectors solder type, set of 10	3.00 set	A-14578 S	1928-31 Headlight and horn conduit set	10.50
B-14487 HL	1928-31 Headlight wire bullet end - flat tip	.50 ea.	A-14584	1928-31 Headlight plug (3-hole) fits 2-bulb headlights	.85 ea.
A-14550	1928-31 Battery cable support. Holds the battery cable so it will not rub the pedals. Includes Grommet.	2.95	A-14584 A	1928 Early headlight 2-hole plug with brass terminal. Set for both lights.	8.50 set
A-14550 G	Grommet for cable support	1.25	A-14585	1928-31 Clips that hold wire to the frame (10 pcs set)	1.30 set
A-14560 S	1928-31 Terminal box assembly complete with lid	8.50	A-14591	Wire holder & cowl panel clip.	4.15
A-14561 A	1928-31 Terminal box lid	2.10	A-14591 GR	Wire holder clip grommet only	.60 ea.
A-14561 WN	1928-31 Terminal box wing nut	1.60 pr.	A-14595	1928 Drum tail light wire clip. Clips onto cast iron bracket	2.90 pr.
A-14577 A	1928-31 Firewall and water inlet wire clip. Also used on inside of firewall for 1928-30 speedometer cable	1.25	A-14600 AS	1928-31 Firewall, choke, and terminal box grommet set	4.75
			A-14600 BS	1931 (Late) firewall, choke, terminal box, and sediment bulb grommets.	6.50
			B-14567	Speedometer cable housing grommets	.75

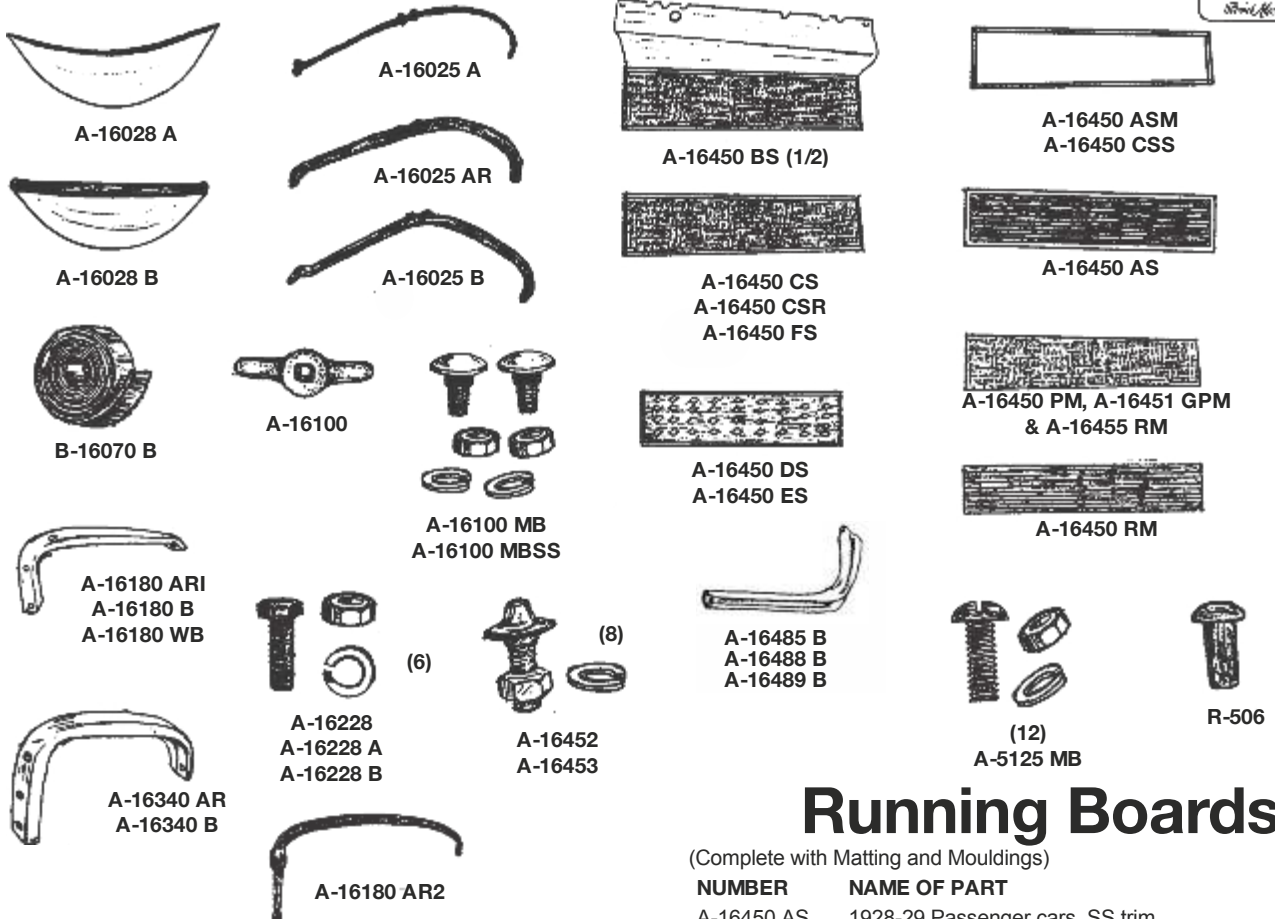

Fender Well

NUMBER	NAME OF PART	PRICE
A-16028 A	1928-29 Fender well	40.00
A-16028 B	1930-31 Fender well	36.00
B-16070 B	Black fender well. Fits between fenders and body (25 ft.)	14.00

Fender Braces

NUMBER	NAME OF PART	PRICE
A-16025 A	1928-29 Cast iron fender brace	Disc.
A-16025 AR	1928-29 Stamped steel front fender brace	37.95
A-16025 B	1930-31 Stamped steel front fender brace	37.95
A-16100	Fender brace clip. See page 102.	4.50
A-16100 MB	1928-31 Fender edge bolts, 4 bolts & nuts	2.00 set
A-16100 MBSS	Stainless steel fender edge bolts, 2 bolts & nuts	2.25 set
A-16180 ARI	1928-31 Pressed steel rear fender brace for roadsters, coupes and pickups.	16.00 ea.
A-16180 AR2	1928-29 Cast iron rear fender brace for roadsters, coupes and pickups	28.00 ea.
A-16180 WB	1931 Wide bed pickup fender brace	17.00 ea.
A-16228	1928-31 Front fender brace to frame bolt set	3.50
A-16228 A	1930-31 Front fender brace to frame bolt set	2.50
A-16228 B	1928-31 Rear fender brace bolts	2.75
A-16340 B	1928-31 Sedan rear fender brace, pressed steel	16.00 ea.

Running Boards

(Complete with Matting and Mouldings)

NUMBER	NAME OF PART	PRICE
A-16450 AS	1928-29 Passenger cars, SS trim	235.00 pr.
A-16450 ASM	1928-29 "Smoothie" passenger car running board for the street rod	235.00
A-16450 ASR	1928-29 Passenger cars, (show quality)	Disc.
A-16450 BS	1930 including splash apron, SS trim	315.00 pr.
A-16450 CS	1931 Running boards, SS trim	235.00 pr.
A-16450 CSR	1931 Running boards, (show quality)	410.00
A-16450 CSS	1930-31 "Smoothie" street rod running boards. Smooth, no mat, no trim	235.00 pr.
*A-16450 DS	1928-29 pickup with Ford script. Show quality, ready to paint	260.00
A-16450 ES	1930-31 pickup. Show quality, ready to paint	260.00
A-16450 FS	1930 Running boards without splash aprons	235.00 pr.
A-16450 PM	1930-31 Pyramid matting	23.50 pr.
A-16450 RM	1928-29 Ribbed matting	23.50 pr.
A-16451 GPM	1931 Pyramid matting with moulded half round edge & adhesive backing	80.00 pr.
A-16452	1928-29 Running board bolts with nuts and washers (set of 8) For cast iron braces	3.50 set
A-16453	1930-31 Running board bolts with nuts and washers for stamped steel brace (set of 8)	3.00 set
A-16455 PM	1930-31 Running board matting. Pyramid design with adhesive	41.00
A-16455 RM	1928-29 Running board matting. Ribbed design with adhesive	38.50

Running Board Braces

NUMBER	NAME OF PART	PRICE
A-16485 B	1929-31 Front right or left running board brace	28.00 ea.
A-16488 B	1929-31 Right hand rear running board brace	28.00 ea.
A-16489 B	1929-31 Left hand rear running board brace	28.00 ea.
A-5125 MB	Running board bracket bolt kit	3.25
R-506	Round head running board brace rivet	5.75 set.

Running Board Trim

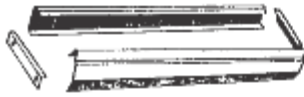

A-16462 AS
A-16462 SS

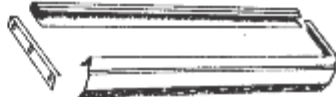

A-16462 B1
A-16462 B2SS



A-16462 C1
A-16462 C2SS



20 pc.
A-16465

NUMBER	NAME OF PART	PRICE
A-16462 AS	1928-29 Zinc	75.00
A-16462 B1	1930 Zinc	75.00
A-16462 C1	1931 Zinc	54.00
A-16462 SS	Stainless 1928-29	75.00
A-16462 B2SS	Stainless 1930	75.00
A-16462 C2SS	Stainless 1931	63.00
A-16465	1930 Inner edge moulding bolt set	5.50

NOTE: Running board trim was designed for reproduction running boards and is not recommended for original running boards.

Running Board Step Plates



A-16400 BS



A-16400 DLX

NUMBER	NAME OF PART	PRICE
*A-16400 BS	Aluminum step plates with Ford script in oval	36.50 pr.
A-16400 BT	Stainless steel oval head mounting bolts with nuts & lock-washers. Mounts one pair.	1.95 set
*A-16400 DLX	Deluxe step plate with aluminum frame and rubber insert with Ford emblem 11 1/2" x 7 1/2"	80.00
A-16400 E	Step plate emblem, blue with Ford script and stud	25.00

Running Board Shields



A-16535/36 A1S

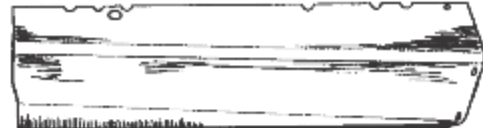

A-16535/36 CS



A-16535/36 A2S



A-16535/36 DS

NUMBER	NAME OF PART	PRICE
A-16535 MB	1928-31 Running board splash apron mounting bolts	2.00
A-16535/36 A1S	1928-29 Running board shield with hump for emergency brake arms	195.00 pr.
A-16535/36 A2S	Early 1928, Running board shield without hump	210.00 pr.
A-16535/36 CS	1930 pickup running board shields	145.00 pr.
A-16535/36 DS	1931, Die stamped (1 piece construction)	190.00 pr.
A-16050 L	1930 Left hand die stamped fender shield	54.95 ea.
A-16050 LH	1930 Fender shield with side mount arm hole	59.00
A-16050 R	1930 Right hand die stamped fender shield	54.95 ea.
A-16050 RH	1930 Fender shield with side mount arm hole	59.00
A-16538/39	1931 Die stamped, 1 pc. aprons with hole for side mounts. Specify left, right or both	200.00



A-16050 L

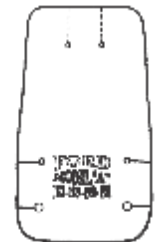

A-16000 FC

Fender Cover

NUMBER	NAME OF PART	PRICE
A-16000 FC	1929-31 Black vinyl with white "Ford Model A" silk-screen and foam backing. Used to protect fender while working on engine.	19.95

Fenders (Steel)

* Official Licensed Product
Official Licensed Product



A-16000
(set of 4)

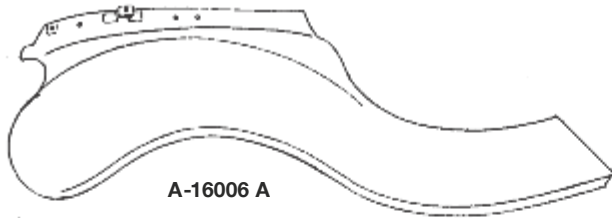

A-16006 A

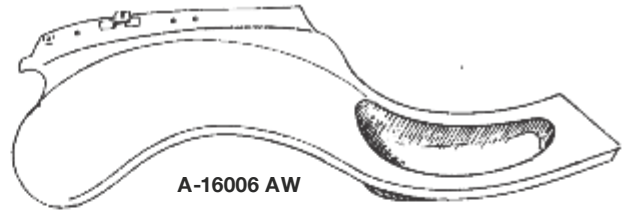

A-16006 AW



A-16007 SK



A-16100

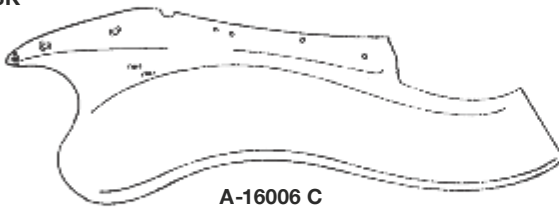

A-16006 C



A-16006 CW

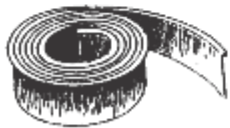

B-16070 B



A-16000 P
A-16000 P2

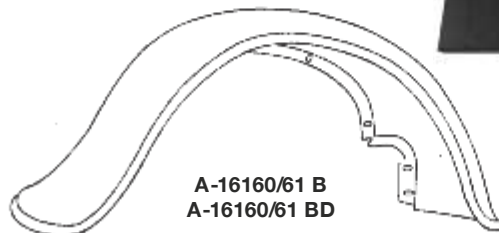

A-16160/61 B
A-16160/61 BD

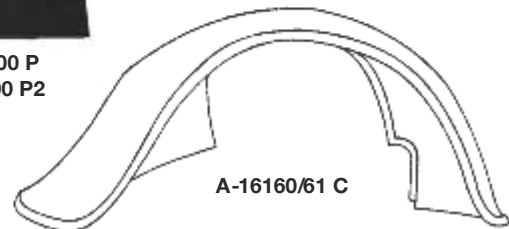

A-16160/61 C

NUMBER	NAME OF PART	PRICE
A-16000	1930-31 Hole patch on fender where it bolts to the frame. Set of 4	7.50
A-16000 P	1928-29 Headlight bar fender hole patch.	7.95
A-16000 P2	1930-31 Headlight bar fender hole patch.	7.95
A-16000 T	Fender bead straightener. Modified vise grips used to straighten outer fender bead.	Disc.
A-16005 A	1928-29 RH front fender	470.00 ea.
A-16005 AW	1928-29 RH front welled fender	580.00 ea.
A-16005 C	1930-31 RH front fender	435.00 ea.
A-16005 CW	1930-31 RH front welled fender	565.00 ea.
A-16006 A	1928-29 LH front fender	470.00 ea.
A-16006 AW	1928-29 LH front welled fender	580.00 ea.
A-16006 C	1930-31 LH front fender	435.00 ea.
A-16006 CW	1930-31 LH front welled fender	565.00 ea.
B-16070 B	Black fender welt. Fits between fenders and body (25 ft.)	14.00
A-16100	Fender Brace Clip. Small cast clip that goes between fender bracket and the fender to prevent damage.	4.50 ea.

NUMBER	NAME OF PART	PRICE
A-16160/61A	1928-29 Right & left rear fenders coupe, roadster & pickup	Disc.
A-16160/61 AD	1928-29 Right & left rear fenders coupe, roadster & pickup. Better quality than the cheaper ones.	335.00 ea.
A-16160/61 B	1930-31 Right & left rear fenders coupe, roadster & pickup	Disc.
A-16160/61 BD	1930-31 Right & left rear fenders coupe, roadster & pickup. Better quality than the cheaper ones.	335.00 ea.
A-16160/61 C	1930-31 Sedan rear fender	335.00 ea.
A-16160/61 D	1928-29 Sedan rear fender	335.00 ea.

SOME FENDERS MUST BE SHIPPED BY TRUCK, FREIGHT COLLECT OR PICKED UP. **NOTE: UPS NOW CHARGES 70 POUND RATE ON REAR FENDERS.**

A-16007 SK	1928-31 Special flat head stud with square shoulder used to mount rear fenders at fender well and pickup fenders to the side of the bed. Set of 20.	13.00 set
A-16162 A	1928-29 Coupe-roadster splash apron/fender reinforcement	16.00 pr.
A-16162 B	1930-31 Coupe-roadster splash apron/fender reinforcement	16.00 pr.
A-16163 A	1928-29 Sedan splash apron/fender reinforcement	16.00 pr.
A-16163 B	1930-31 Sedan splash apron reinforcement	16.00 pr.
A-16164 A	1928-29 Lower running board to fender reinforcement (all body types)	13.00 ea.
A-16164 B	1930-31 Lower running board reinforcement (all body types)	13.00 ea.

Fiberglass Fenders on Page 105

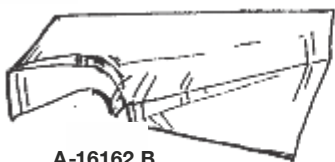

A-16162 B

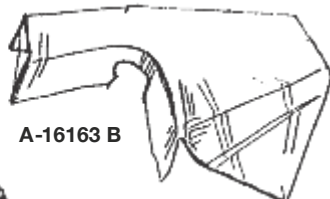

A-16163 B



A-16000 T

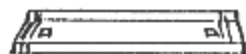

A-16164 A
A-16164 B

Fender Patch Panels



FPP-1



FPP-2



FPP-5



FPP-3



FPP-6



FPP-4



PJ-IR



PJ-6



PJ-1DLX

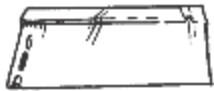

PJ-IF



PJ-5



A-55356 L
A-55357 R



A-114 BL
A-114 BR

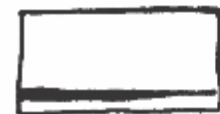

PJ-7



PJ-8

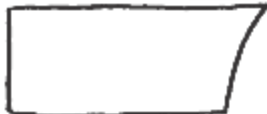

PJ-3



A-114 A



PJ-10



PJ-12

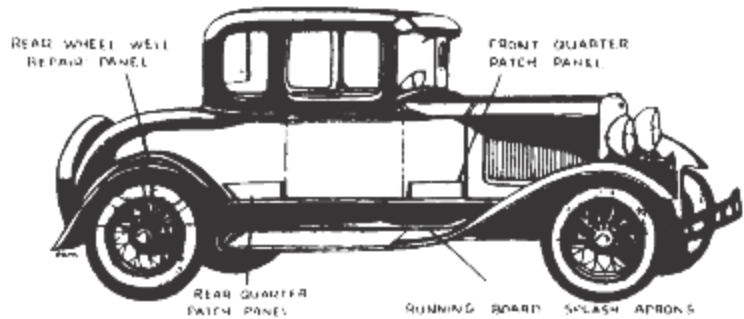

NUMBER	NAME OF PART	PRICE
FPP-1	1928-31 Briggs & Murray, single hump die stamped	60.00 pr.
FPP-2	1928-31 Tudor Sedan, two hump, die stamped	60.00 pr.
FPP-3	1928-31 Roadster, die stamped	60.00 pr.
FPP-4	1928-31 Coupe & Cabriolet, die stamped	57.00 pr.
FPP-5	1928-29 Phaeton Fordor, die stamped	55.00 pr.
FPP-6	1930-31 Phaeton Fordor, die stamped	65.00 pr.
FPP-BT	Rear wheel housing studs. Have large flat head & holds rear fender to body. 4 pc. set	2.00
A-450 BPL	1930-31 Left Tudor rear quarter panel bead patch.	65.00
A-450 BPR	1930-31 Right Tudor rear quarter panel bead patch.	65.00

The die stamped panels are much nearer the original and have all the correct indentions.

NUMBER	NAME OF PART	PRICE	NUMBER	NAME OF PART	PRICE
A-114 A	1928-29 Cowl quarter panel (except Briggs & Murray. USA mfg.)	160.00 pr.	PJ-6	1928-29 Front door post patch panel roadster, phaeton, roadster pickup	86.85 pr.
A-114 BL	1930-31 Open car cowl panel. Left side	165.00	PJ-7	1928-29 Roadster pickup rear quarter patch panel	45.95
A-114 BR	1930-31 Open car cowl panel. Right side	165.00	PJ-8	1930-31 Coupe rear quarter patch	59.00 pr.
PJ-IF	1930-31 Right and left cowl patch flat	21.95 pr.	PJ-10	1930-31 Tudor sedan rear quarter patch	59.00 pr.
PJ-IR	1930-31 Right and left cowl patch with slight radius at bottom	59.00 pr.	PJ-12	1930-31 Roadster rear quarter patch	59.00 pr.
PJ-3	1928-29 Coupe, cabriolet, sport coupe rear quarter patch	59.00 pr.	A-55356 L	1928-29 Left open car door post	240.00 ea.
PJ-4	1928-29 Tudor sedan rear quarter patch	59.00 pr.	A-55357 R	1928-29 Right open car door post	240.00 ea.
PJ-5	1928-29 Roadster rear quarter patch panel	59.00 pr.			
PJ-1DLX	1930-31 Cowl patch panel, most authentic 8" high	65.95			

Door Bottom Patch Panels

NUMBER	NAME OF PART	PRICE
A-136 A	1928-29 Roadster	59.00 pr.
A-136 B	1930-31 Roadster	69.00 pr.
A-308 BSL	1930-31 Coupe left door skin	95.00 pr.
A-308 BSR	1930-31 Coupe right door skin	95.00 pr.
A-336 A	1928-29 Coupe	59.00 pr.
A-336 B	1930-31 Coupe	69.00 pr.
A-436 A	1928-29 Tudor	59.00 pr.
A-436 B	1930-31 Tudor	69.00 pr.
A-436 BC	1930-31 Tudor & pickup door skin. Fits from bottom of door to door bead. Can be cut to fit 1930-31 coupe.	75.00 ea.
A-836 A	1928-29 Pickup	69.00 pr.
A-836 B	1930-31 Pickup	69.00 pr.
A-836 ESL	1928-29 Pickup door skin left	103.00
A-836 ESR	1928-29 Pickup door skin right	103.00



A-436 B

A-436 BC

Rear Body Corner Patch Panel

NUMBER	NAME OF PART	PRICE
A-170 A	1928-29 Roadster and Coupe	35.00 pr.
A-370 B	1930-31 Coupe and Roadster	35.00 pr.
A-470 B	1930-31 Tudor	35.00 pr.
A-870 B	1930-31 Closed cab pickup	35.00 pr.
A-170 ST	T strip between quarter & back panel on 1928-31 sedan	44.00

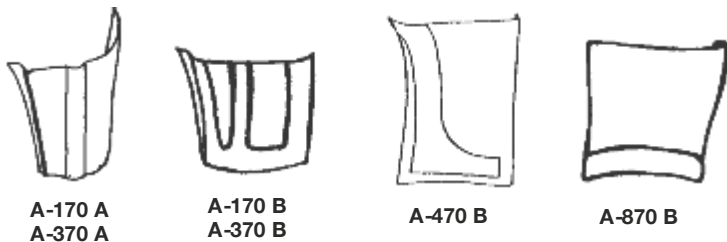

A-170 A
A-370 A

A-170 B
A-370 B

A-470 B

A-870 B



AFG 16005 AR

NUMBER	NAME OF PART	PRICE
AFG 16005 AR	1928-29 RH fiberglass front fender	295.00 ea.
AFG 16005 B	1930-31 RH fiberglass front fender	295.00 ea.
AFG 16006 AR	1928-29 LH fiberglass front fender	295.00 ea.
AFG 16006 B	1930-31 LH fiberglass front fender	295.00 ea.
AFG 16160 AR	1928-29 RH coupe and roadster rear fender, pickup	220.00 ea.
AFG 16160 B	1930-31 RH coupe and roadster rear fender, pickup	220.00 ea.



A-437 B

Door Parts

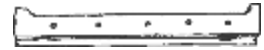

A-336 ADB

NUMBER	NAME OF PART	PRICE
A-336 ADB	1928-29 Coupe inner door bottom, 2-door	35.00 pr.
A-336 BDB	1930-31 Coupe inner door bottom	35.00 pr.
A-436 ADB	1928-29 Sedan inner door bottom 2-door	35.00 pr.
A-436 BDB	1930-31 Sedan & pickup inner door bottom	35.00 pr.
A-437 B	1928-31 Inner door upright, with window stops, all closed cars	42.00 pr.
A-836 ADB	1928-29 Closed cab pickup inner door bottoms	46.00 pr.

Front Radiator Splash Shield

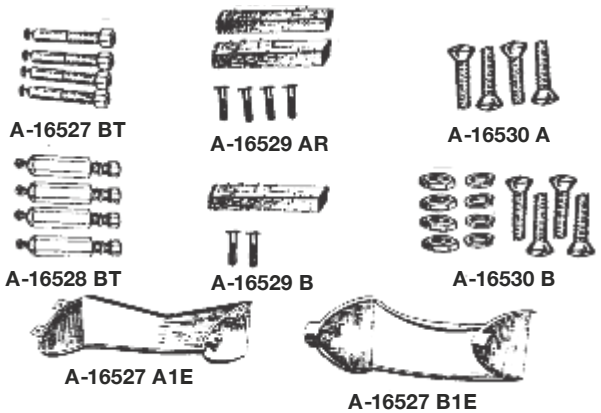

A-16527 BT

A-16529 AR

A-16530 A

A-16528 BT

A-16529 B

A-16530 B

A-16527 A1E

A-16527 B1E

NUMBER	NAME OF PART	PRICE
A-16527 A1E	1928-29 Radiator splash shield, die stamped, show quality	79.50
A-16527 B1E	1930-31 Radiator splash shield, die stamped, show quality	79.50
A-16527 A1	1928-29 Radiator splash shield	55.00
A-16527 B1	1930-31 Radiator splash shield	45.00
A-16527 BT	1930-31 Round splash shield stud set replacement	8.00 set
A-16527 BSR	1930-31 Radiator apron made to fit 1932 Radiator shell	80.00
A-16528 BT	1930-31 Authentic Hex splash shield stud set	20.75 set
A-16529 AR	1928-29 2 Pads with rivets	1.25
A-16529 B	1930-31 Pad	.75
A-16530 A	1928-29 Radiator shield screw set	1.50
A-16530 B	1930-31 Radiator shield screw set	2.00
A-16530 C	1930-31 Radiator apron round head s/s stud screw (4) Threads into bumper bracket studs	1.25

Fiberglass Fenders

NUMBER	NAME OF PART	PRICE
AFG 16161 AR	1928-29 LH coupe and roadster rear fender, pickup	220.00 ea.
AFG 16161 B	1930-31 LH coupe & roadster rear fender, pickup	220.00 ea.
**AFG 16310 AR	1928-29 RH touring & sedan rear fender	220.00 ea.
**AFG 16310 B	1930-31 RH touring & sedan rear fender	220.00 ea.
**AFG 16311 AR	1928-29 LH touring & sedan rear fender	220.00 ea.
**AFG 16311 B	1930-31 LH touring & sedan rear fender	220.00 ea.

**DOES NOT FIT LATE 1931 SLANT WINDSHIELD CARS

Hood

* Official Licensed Product
Ward's Auto Accessories

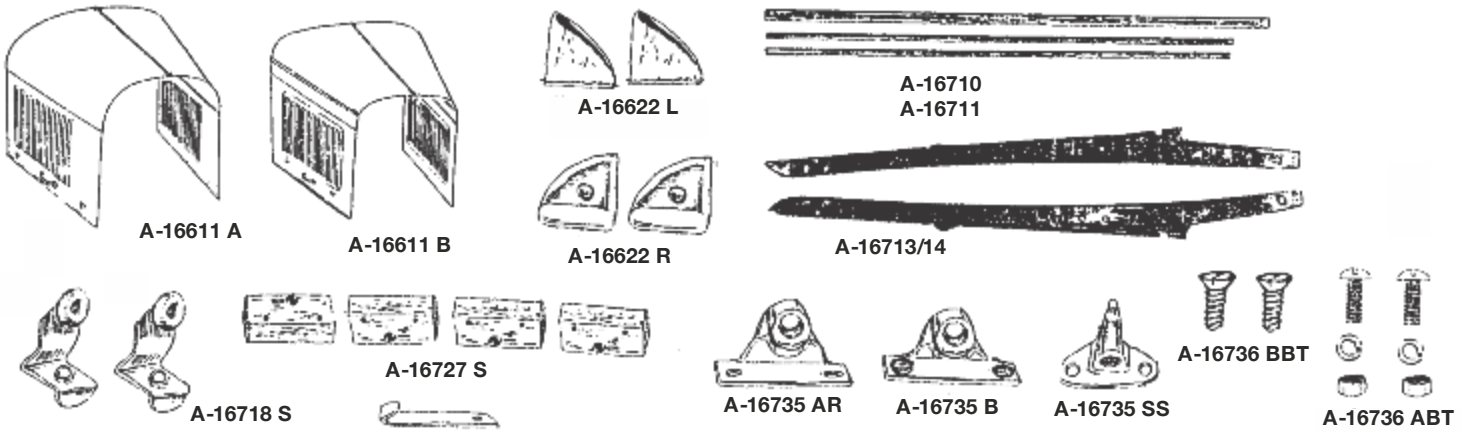

NUMBER	NAME OF PART	PRICE
A-16611 A	1928-29 Hood complete with hardware. roadster, coupe, tudor & pickup.	450.00
A-16611 B	1930-31 Hood complete with hardware.	490.00
A-16622 L	Leather hood corners	3.50 pr.
A-16622 R	Moulded rubber hood corners	3.25 pr.
A-16710	1928-29 Solid S/S hood hinge rods	13.95 set
A-16711	1930-31 Solid S/S hood hinge rods	13.95 set
A-16713/14	1928-29 Hood shelves	38.00 pr.
A-16718 S	1930-31 Center hood clip bracket, powder coated	6.00 set

NUMBER	NAME OF PART	PRICE
A-16727 S	1928-29 Hood clamp block set	9.00 set
A-16735 AR	1928-29 Rear hood retainer	6.00
A-16735 B	1930-31 Rear hood retainer	5.25
A-16735 C	1930-31 Rear hood hinge retainer chrome	9.00
A-16735 SS	1930-31 Stainless Steel rear hood retainer	Disc.
A-16736 A	1928-29 Hood hinge shims - .015	.60
A-16736 B	1930-31 Hood hinge shims - .015	.65
A-16736 ABT	1928-29 Hood retainer screws	.95 set
A-16736 BBT	1930-31 Hood retainer screws	.95 set
A-16737	1930-31 Cowl lacing clip	.50 ea.

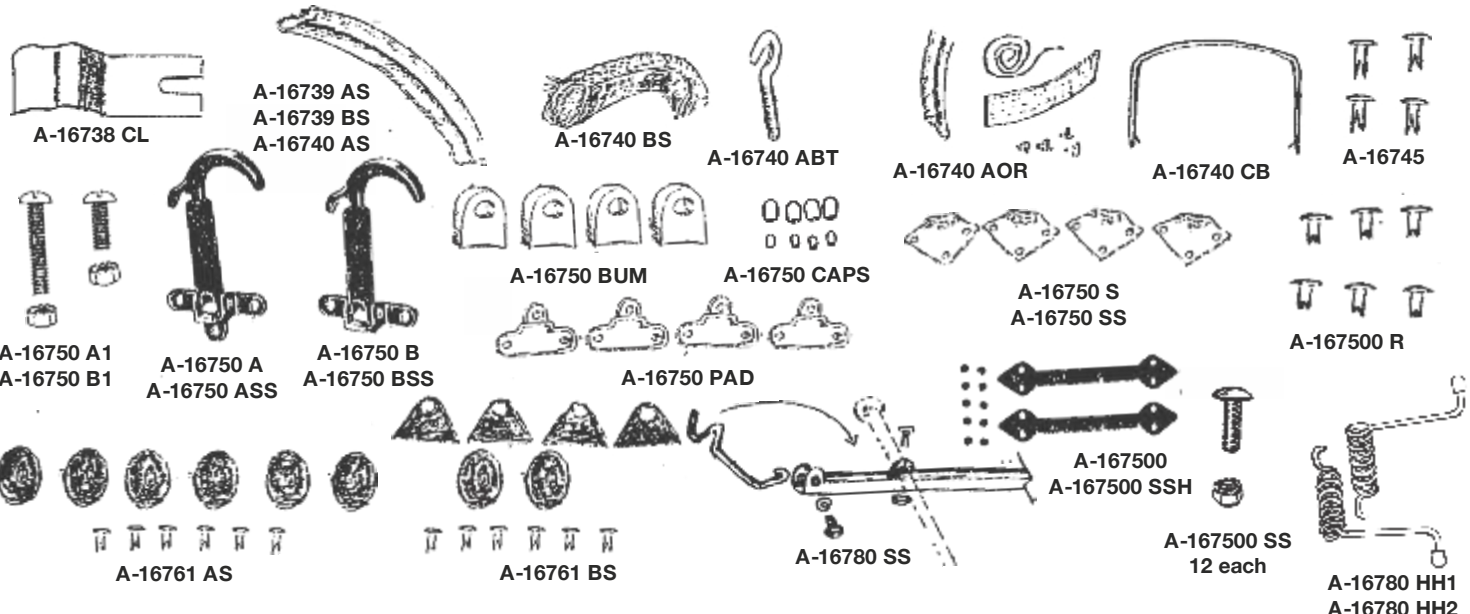

NUMBER	NAME OF PART	PRICE
A-16738 CL	1930-31 Cowl band support clip set	2.95 set
A-16739 AS	1928-29 Radiator shell face kit	8.00
A-16739 BS	1930-31 Radiator shell face kit	8.50
A-16740 AS	1928-29 Cowl lacing kit	9.00
A-16740 BS	1930-31 Cowl lacing kit	13.50
A-16740 ABT	Cowl Lace Top Wire Hook	1.95
A-16740 AOR	Original style cowl lacing. Uses a wire to hold the lacing down over the gas tank.	13.25
A-16740 CB	Polished stainless steel cowl band w/mtg. bolts	80.00
A-16745	1928-31 Radiator & cowl lacing rivets. Set of 24.	1.25 set
A-16750 A	1928-29 3-hole black hood latch	8.00
A-16750 B	1930-31 2-hole black hood latch	8.00
A-16750 A1	1928-29 Stainless steel hood clip bolt set	2.50 set
A-16750 B1	1930-31 Stainless steel hood clip bolt set	2.50 set
A-16750 ASS	1928-29 3-hole stainless steel hood latch	13.00 ea.
A-16750 BSS	1930-31 2-hole stainless steel hood latch	13.00 ea.
A-16750 BUM	1928-31 Hood latch bumpers (Fits around latch to make it rattle-free.)	3.25 set

NUMBER	NAME OF PART	PRICE
A-16750 CAPS	1928-31 Hood latch tips	1.25 set
A-16750 PAD	1928-31 Hood latch pad (Trim off the lip for 30-31)	4.25 set
A-16750 S	1928-32 Hood clip bracket - Original style.	4.95 set
A-16750 SS	1928-32 Hood clip bracket stainless	12.00 set
A-167500	Hood handles & rivets	25.00 pr.
A-167500 R	Hood handle and clip rivet set (pkg. of 20)	1.50 pkg.
A-167500 SS	Stainless steel bolts with rivet head and nuts. Used to bolt hood handles and latches.	3.95 set
A-167500 SSH	1928-31 stainless steel hood handle	30.00
A-16761 AS	1928-30 Hood bumper set	3.50 set
A-16761 BS	1931 Hood bumper set	3.50 set
A-16780 SS	1928-31 Hood Hold-Up. Stainless steel arm and hardware. Rubber coated tips. Arms flip out to hold hood up when open. 1/2 set shown. Two pairs of arms enclosed for your convenience.	25.00 set
A-16780 HH1	1928-29 Hood hold up. Fits on hood rod and dash bracket. Vinyl covered	19.95 pr.
A-16780 HH2	1930-31 Hood hold up. Fits on hood rod and dash bracket. Vinyl covered	19.95 pr.
A-16780 X	Hood hold up, mounts on hood rain gutter	9.95

Speedometer

* Official Licensed Product
Stewart Warner Company

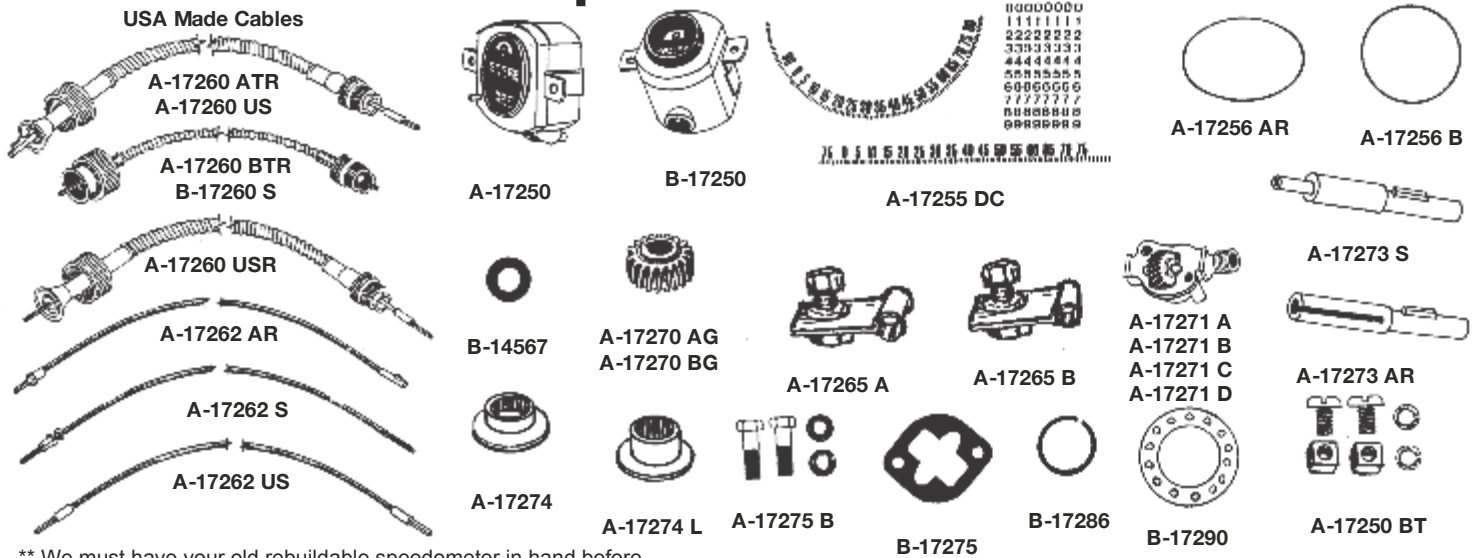

** We must have your old rebuildable speedometer in hand before shipping. If it is not rebuildable it will be returned to you and a core charge will be required before shipment.

NUMBER	NAME OF PART	PRICE
B-14567	1928-31 Speedometer cable housing grommet	.75
**A-17250	Rebuilt oval speedometer. Exchange only.	190.00
**B-17250	Rebuilt round speedometer. Exchange only.	190.00
A-17250 BT	Screws w/special large nuts for mounting speedometer	.80
A-17255 DC	Oval Stewart Warner speedometer decal set	2.25
A-17255 DR	Round Stewart Warner speedometer decal set	2.35
A-17255 NE	Round Northeast speedometer decal set	3.00
A-17255 W	Round Waltham speedometer decal set	2.85
A-17256 AR	1928-30 Oval speedometer lens and gaskets	2.25
A-17256 B	1930-31 Round speedometer lens and gaskets	2.00
A-17257 AR	1928-30 Oval lens gaskets	.85 pr.
A-17257 B	1930-31 Round lens gaskets	.85 pr.
A-17260	1928-30 Speedometer cable & housing, import	28.00
A-17260 ATR	Same as A-17260 US for AA truck 85" or you specify length - USA MFG	53.00
A-17260 A89	1928-30 AA Truck speedometer cable 89" USA MFG	57.00
A-17260 A113	1928-29 AA Truck speedometer cable 113" USA MFG	63.50
A-17260 BTR	Same as B-17260 S for AA truck 85" or you specify length - USA MFG	30.00
A-17260 B71	1930-31 71" Inch passenger speedometer Cable - USA MFG	30.00
A-17260 B89	1930-31 AA Truck speedometer cable 89" USA MFG	32.00
A-17260 B113	1930-31 AA Truck speedometer cable 113" USA MFG	36.00
A-17260 US	1928-30 Speedometer cable and housing with large housing and special keyed end w/nylon bushing, USA MFG	47.00
A-17260 USR	1928-30 Large cable & housing altered to fit oval speedometer to small square end drive gear - USA MFG	47.00
B-17260 S	1930-31 Small speedometer cable and housing, USA MFG	25.00
B-17260 USR	1930-31 Small cable & housing altered to fit round speedometer to keyed drive gear shaft USA MFG	33.50
A-17262 OR	1930-31 Replacement inner cable for original small housing	10.50
A-17262 US	Replacement inner cable for A-17260 US for Smith & Jones mfg. Cables - USA MFG	16.50

NUMBER	NAME OF PART	PRICE
A-17262 AR	1920-30 Speedometer cable for big housing, original style.	7.95
A-17258 BR	1930-31 Round speedometer lens retainer	2.95
A-17268 SW	1930-31 Stewart Warner round faceplate, black	7.00
A-17262 S	1930-31 Replacement inner speedometer cable for small housing (for Smith and Jones mfg. cables) USA MFG	10.50
A-17265 A	1928-30 Speedometer cable support clip (large cable)	2.25
A-17265 B	1930-31 Speedometer cable support clip (small cable)	2.25
A-17270 AG	1928-31 Speedometer drive gear for 3.78 rear end, gear only	12.75
A-17270 BG	1928-31 Speedometer drive gear for 3.54 rear end, gear only	12.75
A-17270 N17	17 Tooth speedometer drive gear - Nylon (3.54 with 21" tires)	21.00
A-17270 N18	18 Tooth speedometer drive gear - Nylon (3.54 with 19" tires)	21.00
A-17270 N19	19 Tooth speedometer drive gear - Nylon (3.78 with 21" tires)	21.00
A-17270 N20	20 Tooth speedometer drive gear - Nylon	21.00
A-17270 N21	21 Tooth speedometer drive gear - Nylon (4.11 with 21" tires)	21.00
A-17271 A	1928-30 Speedometer gear case and assembly, fits keyed end cable 3.78 w/21" tires	69.95
A-17271 B	1930-31 Speedometer gear case and assembly, fits square end cable 3.78 w/19" tires	69.95
A-17271 C	1928-30 Speedometer gear case and assembly. Fits keyed end cable 3.54 w/21" tires	69.95
A-17271 D	1928-31 Speedometer gear case and assembly. Fits square end 3.54 w/19" tires	69.95
A-17271 E	1930 Speedometer gear case assembly, fits square end cable (3.78:1 with 19" tires)	69.95
A-17273 AR	1928-30 Speedometer drive gear shaft	10.50
A-17273 S	1930-31 Speedometer drive gear shaft	12.75
A-17274	1928-30 Oval speedometer drive gear shaft retainer	1.25
A-17274 L	1928-31 Round speedometer drive gear shaft retainer	1.25
B-17275	1928-48 Speedometer gear case assembly gasket	.40
A-17275 B	Speedometer gear case bolts & lock-washers	.75
B-17286	1928-48 Speedometer gear snap/ring	.75
B-17290	1928-48 Speedometer drive gear thrust washer	2.00

Windshield Wipers

* Official Licensed Product
Trico Motor & Components

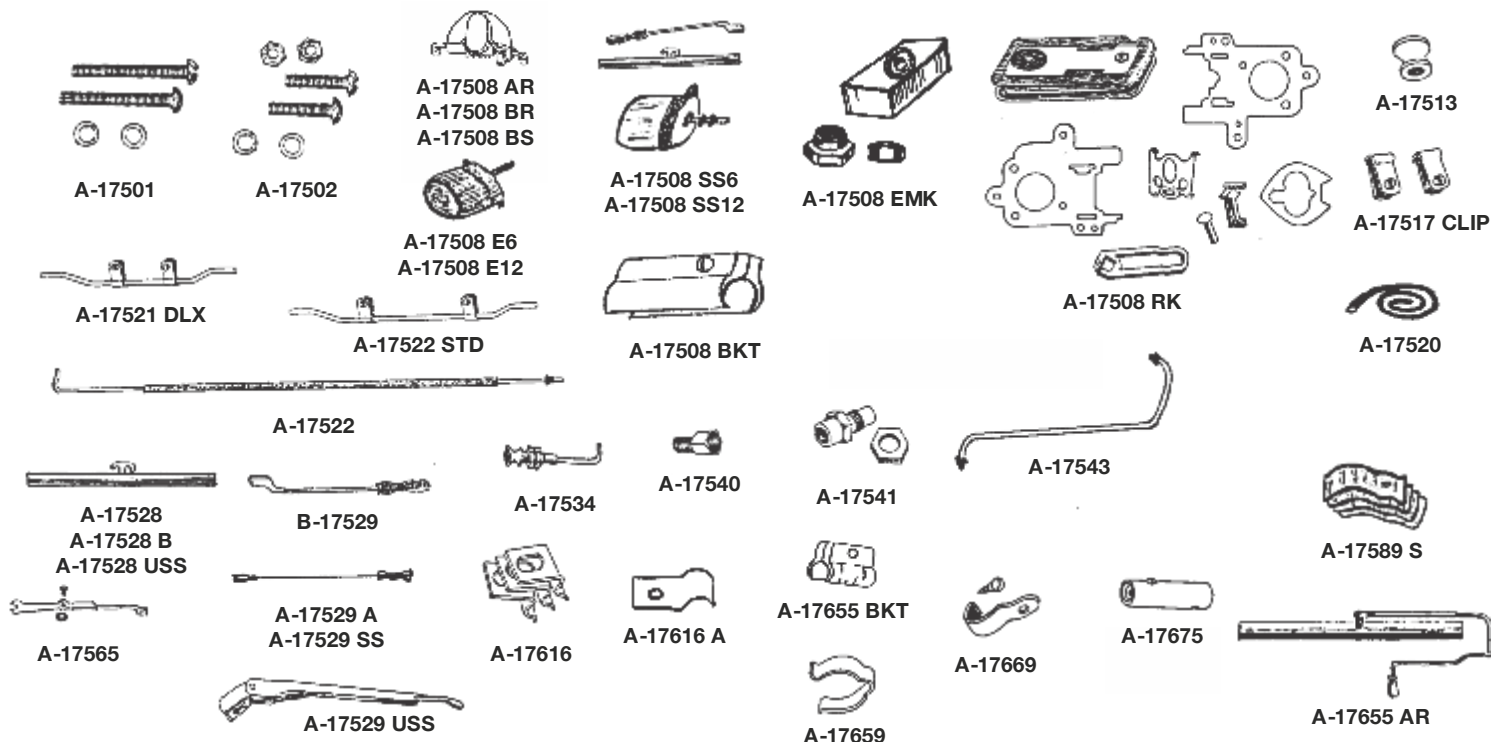

NUMBER	NAME OF PART	PRICE	NUMBER	NAME OF PART	PRICE
A-17501	Wiper mounting bolt set - outside mount	1.00	A-17522 STD	Standard open car stanchion vacuum line with clips	8.25
A-17502	Wiper motor mounting bolt set - inside mount	1.00	A-17528	Wiper blade 7-3/4"	2.35
A-17508 AR	1928-31 Outside mount closed car vacuum wiper motor, rebuilt, exchange	175.00	A-17528 B	Wiper blade 8-1/4"	2.45
A-17508 BKT	Chrome plated bracket used to mount replacement electric wiper motors to open car windshield frames	39.95	A-17528 S	Wiper blade 7-3/4" primed steel	1.50
A-17508 BR	1928-31 Inside mount open car vacuum wiper motor, rebuilt - EXCHANGE ONLY. Must have your core first to send to be rebuilt	175.00	A-17528 USS	Universal blade 11" for use with A-17529 USS and S/S wiper motors	5.00
A-17508 BS	1928-31 Open car outside mount vacuum motor shaft. Replaces worn, bent or broken original shafts perfectly.	Disc.	B-17529	1930-36 Wiper arm inside mount vacuum motor and electric motor (A-17508 E6 & E12)	4.95
A-17508 E	1930-31 Slant windshield inside mount, rebuilt, exchange	175.00	A-17529 A	Wiper arm outside mount	3.75
A-17508 E6	Replacement 6 volt electric wiper motor inside mount (open car only) w/switch	35.00	A-17529 SS	Stainless steel wiper arm outside mount	Disc.
A-17508 E12	Replacement 12 volt electric wiper w/switch motor inside mount (open car only)	35.00	A-17529 USS	Universal wiper arm for 1/4" shaft S/S, comes in S/S motor kit - adjustable length	10.50
A-17508 G	Trico vacuum motor bowl gaskets	2.35 pr.	A-17534	On/Off control for outside mount vacuum motor	4.00
A-17508 MK	Extra nut and washer set for wiper motor shaft	2.00	A-17540	Vacuum line manifold connector	1.00
A-17508 RK	Vacuum motor repair kit	28.00	A-17541	Vacuum line firewall connector	3.00
A-17508 SS6	S/S 6-volt stainless steel motor & universal arm & blade, w/o switch	47.00 ea.	A-17543	Vacuum line manifold to firewall	4.00
A-17508 SS12	S/S 12-volt stainless steel motor & universal arm & blade, w/o switch	47.00 ea.	A-17565	Electric closed car wiper motor arm original style motor	20.50
A-17513	Chrome pull knob for outside vacuum wiper motor	1.75	A-17589 S	Vacuum wiper motor clamp set	6.00
A-17517 CLIP	Clips for stanchion steel vacuum line	2.65 ea.	A-17616	1930-31 Header clip for wiper (3) closed car. Holds vacuum hose to header in cars and trucks	3.25
A-17519	Vacuum rubber hose (sold by the foot)	.65 ft.	A-17616 A	Electric wiper wire to header clip (Sedans)	1.50 ea.
A-17520	Vacuum wiper hose - 6 ft.	3.25	A-17655 BKT	Chrome plated bracket used to mount hand wiper to open car windshield frames	29.00
A-17521 DLX	Deluxe open car stanchion vacuum line with clips	8.25	A-17655 AR	Early 1928 hand wiper assy.	26.50
A-17522	Closed car inside vacuum line 36" long. Firewall to header	5.00	A-17659	Clip that holds the electric wire on the windshield frame on an open car	2.90 ea.
			A-17669	1928-31 Wiper hose clip for roadsters & phaetons. Clamps hose to w/s frame.	1.50 ea.
			A-17674	Tandem wiper assembly	42.00
			A-17675	Electric wiper motor electrical connection	5.50

Mirrors

* Official Licensed Product
Official Aftermarket Accessories



A-17681 AS

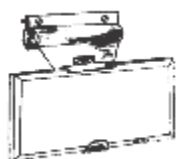

A-17681 SS



A-17682 AS



A-17682 BSS
A-17682 BS



A-17700 A

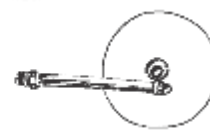

A-17700 P



A-17700 WW



A-17704 A
A-17704 B



A-17704 CL
A-17704 CLK



A-17700 SM



A-17741 A



A-17741 B

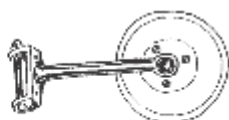

A-17741 AL
A-17741 AR

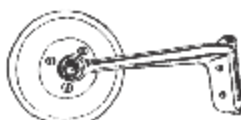

A-17741 BL
A-17741 BR



A-17741 MH



A-17741 UL
A-17741 UR



A-17681 SR



A-17682 SR



A-17741 HP1

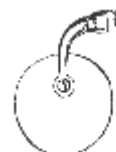

A-18414 L
A-18414 R

NUMBER	NAME OF PART	PRICE	NUMBER	NAME OF PART	PRICE
A-17681 AS	1928-29 Open car, rear view mirror assembly, black	18.75	A-17741 B	Outside hinge pin mirror & bracket assembly for pickup 1930-31	22.50
A-17681 SR	1928-31 Open car inside rear view mirror, S/S oval for street rod	46.00	A-17741 BL	1930-31 Left hand door hinge pin mirror, closed car	38.00
A-17681 SS	1930-31 Open car stainless steel mirror	35.00	A-17741 BR	1930-31 Right hand door hinge pin mirror, closed car	38.00
A-17681 AMB	1928-29 Closed car oval headed machine screws (3) to mount mirror.	.80	A-17741 HP1	1928-31 Hinge pin, 1 3/4" with washer & nut	2.60
A-17681 BMB	1930-31 Closed car chrome oval headed wood screws to mount mirror on the header panel.	.80	A-17741 MH	Mirror head for hinge pin mirror. Stainless	20.50
A-17682 AS	1928-29 Closed car, rear view mirror assembly, black	19.50	A-17741 MHB	Truck mirror head. Black	8.25
A-17682 BS	1930-31 Closed car, rear view mirror assembly, black	28.00	A-17741 UL	Straight arm peep mirror, 4" head. Fits most cars with door edge. Stainless bracket and head, left side.	24.00
A-17682 BSS	1930-31 Closed car rear view mirror, stainless steel	34.00	A-17741 UR	Same as above for right side.	24.00
A-17682 SR	1928-31 Closed car inside rear view mirror S/S oval for street rod	46.00	A-17700 A	Post Mirror for the 1928-29 open car & Roadster Pickup. May require drilling & tapping new hole in stanchion.	38.00
A-17704 A	Rear view mirror glass 2 1/2 x 5 beveled edge	6.00	A-17700 LS	Side mount tire mirror with leather strap	50.00
A-17704 B	Rear view mirror glass 2 1/2 x 6 beveled edge	7.95	A-17700 P	1930-31 Chrome windshield post mirror, screws into w/s stanchion on Roadsters and Deluxe Phaetons.	38.00
*A-17704 CL	Rear view clock mirror, Quartz with silver Arabic numbers, beveled glass	55.00	A-17700 SM	1928-31 Side mount mirror assembly, 4" Bevel edge mirror, stainless steel chain, and 2 key lock	64.00
A-17704 CLK	Rear view mirror clock. Made from acrylic material with quartz clock.	34.00	A-17700 SM	1928-31 Side mount mirror assembly, 4" Bevel edge mirror, stainless steel chain, and 2 key lock	64.00
A-17741 A	Outside mirror and bracket assembly for 1928-29 closed cab Pickup, 1928-30 Panel Delivery, AA Panel Delivery, 1928-30 Deluxe Delivery, 1928-29 Taxi, and 1928-31 Station Wagon, USA Mfg.	24.95	A-17700 WW	Wind wing mirror, for all open cars equipped with wind wings.	30.00
A-17741 AL	1928-29 Left hand door hinge pin mirror, closed car - stainless	38.00	A-18414 L	Left hand peep mirror	26.00
A-17741 AR	1928-29 Right hand door hinge pin mirror, closed car - stainless	38.00	A-18414 R	Right hand peep mirror	26.00

Bumper Clamps

* Official Licensed Product
Ford Motor Company

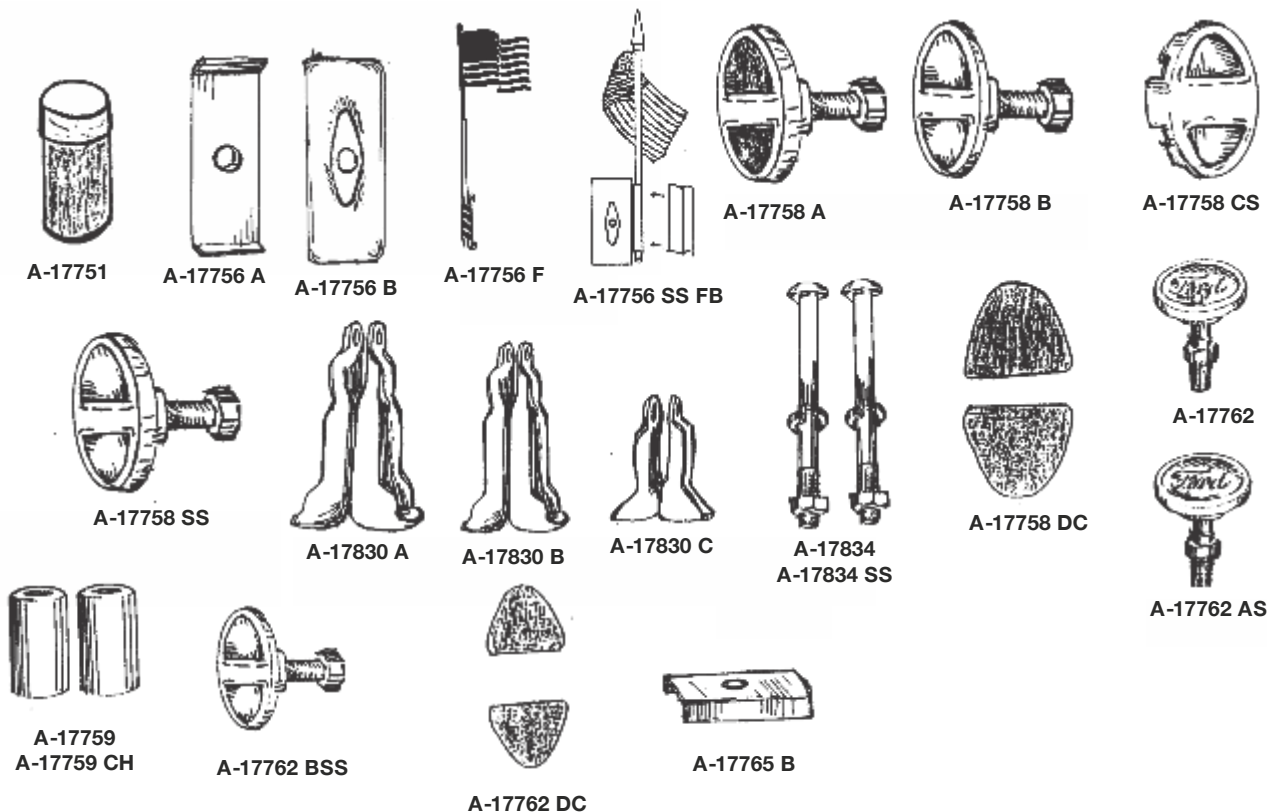

Outer Clamps

NUMBER	NAME OF PART	PRICE	NUMBER	NAME OF PART	PRICE
A-17751	Bumper clamp paint	Disc.	A-17758 CS	1931 Stainless steel covers - use your old outer clamp	5.40 ea.
A-17756 A	1928-29 Large bumper clamp back plate	5.50	A-17758 DC	Blue decal set for painted area of bumper clamp. Enough for 4 clamps.	3.00 set
A-17756 B	1930-31 Large bumper clamp back plate. Stamped steel. Powder coated.	2.80 ea.	A-17758 SS	1931 Thin outer clamp same as original with stainless steel covers.	18.75 ea.
A-17756 F	Spring loaded stainless steel flag holder. Easily attaches to bumper by spring tension. Easy on easy off. Includes bracket and one flag.	31.95	A-17759	Spacers for bumpers (2 each), unplated rolled, black powder coat	2.00 pr.
A-17756 FLAG	USA flag. Mounted on 3/8" wooden dowel 30" high	5.00 ea.	A-17759 CH	Stainless bumper spacers not rolled	7.50 pr.
A-17756 SS FB	Flag bracket set - 4 pc. S/S mounting bracket fits under bumper clamp backing plates. With flags.	15.00 set	A-17830 A	Rear bumper arm to body bracket 1928-31 coupes and roadsters 5" tall	16.00 ea.
A-17758 A	1929-31 Heavy cast steel clamps - chrome plated and painted blue - import	11.95 ea.	A-17830 B	Rear bumper arm to body bracket 1930-31 sedan 4-1/2" tall	16.00 ea.
*A-17758 AR	1928 Heavy cast steel clamps - chrome plated and painted blue (Ford script)	Disc.	A-17830 C	Rear bumper arm to body bracket- 1928-29 fordor & town sedan 3" tall	16.00 ea.
A-17758 B	1929-30 Thin outer clamp same as original used by Ford, USA mfg., chrome	18.00 ea.	A-17834	Bumper end bolts, cadmium	3.95 pr.
			A-17834 SS	Stainless bumper end bolts	10.00 pr.

Center Clamps

NUMBER	NAME OF PART	PRICE	NUMBER	NAME OF PART	PRICE
*A-17762	1926 & 27 Early 28 exact duplicate stamped stainless steel cover	9.75 ea.	A-17762 BSS	1931 Oval stainless steel cover complete. Show quality.	7.75 ea.
*A-17762 AS	1928-29 Exact duplicate with Ford script, stamped stainless steel	9.75 ea.	A-17762-DC	Blue decal for oval center medallion	1.00 ea.
			A-17765 B	Backing plate for center clamp.	.95 ea.

Front Bumper Arms

* Official Licensed Product
Official Licensed Product

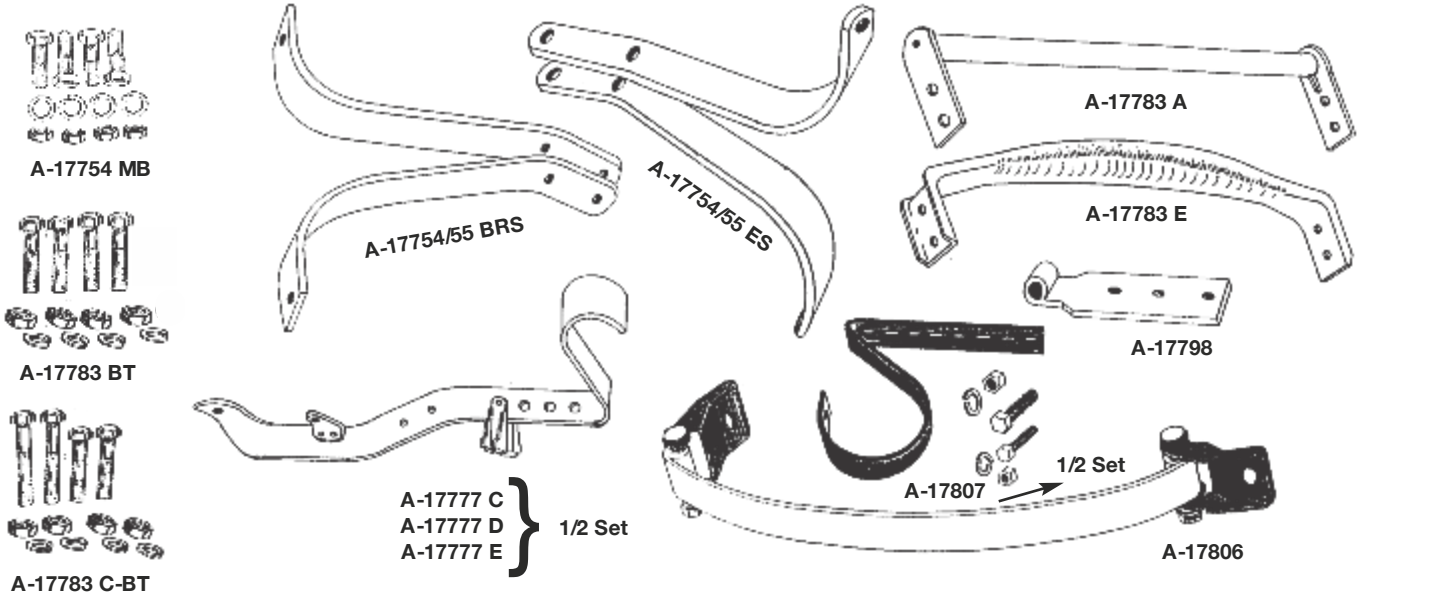

NUMBER	NAME OF PART	PRICE	NUMBER	NAME OF PART	PRICE
A-17754 MB	1928-29 Front bumper bracket bolts	3.25	A-17783 AT	1928-29 Rear cross arm mounting bolts (16 pcs)	8.75
A-17754/55 BRS	1928-29 R & L Bumper Arm	65.00 pr.	A-17783 E	1930-31 Rear bumper arm cross brace	36.00
A-17754/55 ES	1930-31 R & L Bumper Arm	65.00 pr.	A-17783 BT	1930-Early 1931 cross arm mounting bolt kit. Special oval head bolt (12 pcs)	6.50
A-17770 MB	Bolts, nuts & lock-washers needed to install rear bumper bracket and cross brace	5.95	A-17783 C-BT	Late 1931 cross arm mounting bolt kit. Special oval head bolt (12 pcs)	8.75
A-17777 C	1928-29 Rear bumper brace, w/bracket & body stands, Sedan	189.00 set	A-17798	Bumperette spacer to frame bracket (rear) (1930-31)	17.75 ea.
A-17777 D	1930-31 Rear bumper brace - Sedan & Touring w/bracket & body stands	189.00 set	A-17806	1930-31 Spare wheel guard assembly	124.00
A-17777 E	1928-31 Rear bumper brace, Coupe & Roadster with bracket & body stands.	189.00 set	A-17806 BKTS	Spare wheel guard brackets	28.95
A-17783 A	1928-29 Rear bumper arm cross brace	62.00	A-17807	Bumper Extenders. Extends rear bumper 1928-31 behind second spare tire, or behind luggage rack, or allows you to mount spare in front of luggage rack.	260.00 pr.

Bumpers

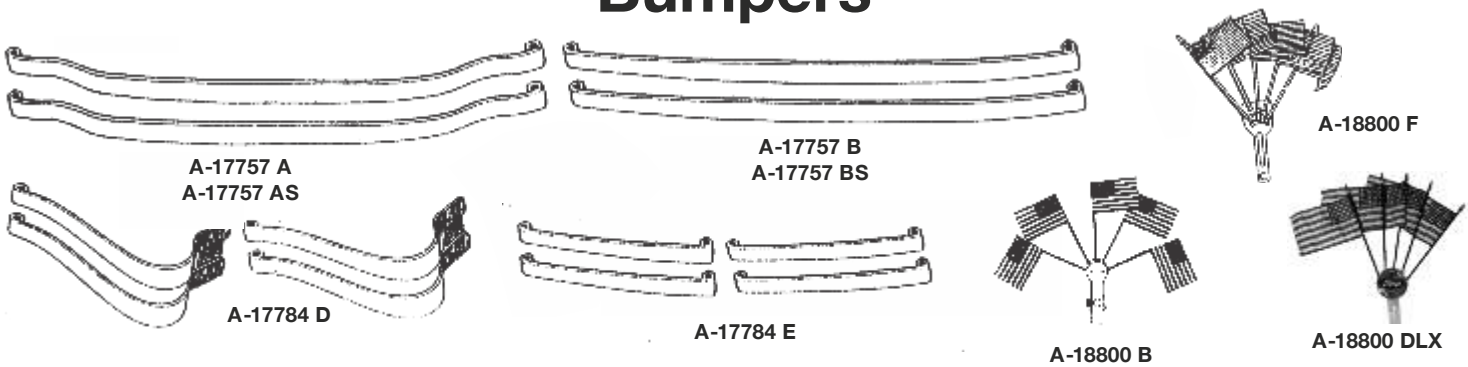

NUMBER	NAME OF PART	PRICE	NUMBER	NAME OF PART	PRICE
A-18800 DLX	Bumper mount flag set with Ford oval on bracket	35.00	A-17784 D	1928-29 Rear bumper bars	275.00
A-18800 F	Flag Set, mounts easily behind center bumper medallion nut. Can be easily modified to be used elsewhere. 5 Flag Type	8.50	A-17784 E	1930-31 Rear bumper bars	260.00
A-18800 FLAG	Extra flags for part A-18800 F / DLX / B	.60 ea.	A-17785 F	1931 Rear bumper bars, 160 A/B/C, 18 1/2" long, 5" arch. Slant windshield	260.00
A-18800 B	Bumper mount flag set. Mounts to flat type double bar bumper	28.75	Bumpers below are stainless steel. They do not have quite as high of luster as chrome but are more durable.		
A-17757 A	1928-29 Front bumper bars	260.00	A-17757 AS	1928-29 Front bumper bars S/S	295.00
A-17757 B	1930-31 Front bumper bars	260.00	A-17757 BS	1930-31 Front bumper bars S/S	295.00
			A-17784 DS	1928-29 Rear bumper bars S/S	295.00
			A-17784 ES	1930-31 Rear bumper bars S/S	295.00

Shock Absorbers

* Official Licensed Product
Official Aftermarket Performance

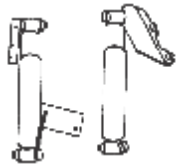

A-18014



A-18015
A-18016

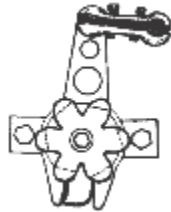

A-18015 FR



A-18015 MB



A-18037 A
A-18037 B

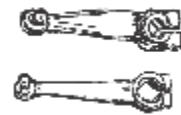

A-18047 B

A-18052 B



A-18047/52 MB



A-18055



A-18060 A



A-18060 S



A-18060 T



A-18058 S



A-18059



A-18061



A-18062

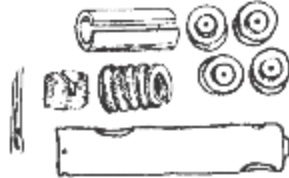

A-18063 BS



A-18064

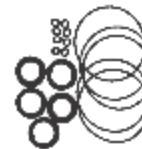

A-18096



A-18097



A-18099

NUMBER	NAME OF PART	PRICE	NUMBER	NAME OF PART	PRICE
A-18014	1928-31 complete modern shock set with brackets. All bolt and clamp on style. !!NO DRILLING REQUIRED!!	325.00	A-18055	Dogbone shock link	5.60
A-18015	Right front or left rear shock, best made	165.00	A-18058 S	Rubber seals for tubular links	4.50
A-18015 FR	1928-31 Friction style shock. Bolts in place of original shocks. Adjustable and also powder coated. Set of 4.	400.00	A-18059	Metal caps for shock (set of 8) link seals	6.25 set
A-18015 MB	Shock mounting bolt set	6.40 set	A-18060 A	Shock link ball seat	1.10
A-18015 SET	Shock absorber set complete with tubular shocks, links, arms, seals & mounting bolts.	780.00	A-18060 S	Dogbone shock link bushing (set of 8)	4.50 set
A-18016	Left front or right rear shock, best made	165.00	A-18060 T	Teflon tubular link shock ball seats. Easy action does not need grease. Set of 16 for 4 shocks.	19.00 set
A-18037 A	Shock absorber needle valve set (Hex head) 1930-31	49.50 set	A-18061	Shock link plug	1.45
A-18037 B	Shock absorber needle valve set (square head) 1928-29	49.50 set	A-18062	Shock link spring	.70
A-18047 B	Front shock arm	25.00	A-18063 BS	Tubular shock link with all internal parts	19.00 ea.
A-18047/52 MB	Shock arm bolt set	6.00 set	A-18064	Shock link sliding spacer	.60
A-18052 B	Rear shock arm	24.00	A-18096	Shock absorber seal kit	28.00
			A-18097	Rear perch and shock arm stud	2.75
			A-18099	Shock absorber fluid (pint)	6.00

Pedal Covers

NUMBER	NAME OF PART	PRICE
A-18422 BS	Duplicate pedal covers, black, 1929-31	3.20 pr.
A-18422 RS	Duplicate pedal covers, red, 1928	Disc.
A-18422 FUL	Deluxe accessory, Fulton pedal covers for brake and clutch.	27.50 pr.
A-18423 FUL	Deluxe accessory, Fulton accelerator pedal cover.	30.00 ea.



A-18422 BS
A-18422 RS



A-18422 FUL



A-18423 FUL

Windwing Brackets



Glass sold separately

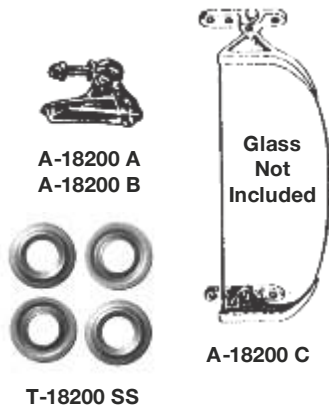

A-18200 E



A-18300

NUMBER	NAME OF PART	PRICE
A-18200 A	1928-29 Open car windwing brackets, complete set	78.00
A-18200 B	1930-34 Open car windwing brackets, complete set	78.00
A-18200 C	1928-31 Closed car windwing brackets, mounts with screws, must drill holes in door to mount, complete set	78.00
A-18200 D	1928-31 Closed car windwing brackets, no holes needed, brackets mount in window track, complete set.	70.00
A-18200 E	1928-35 Windwing bracket rubber for open cars. These rubber pads are made to fit the original stamped windwing brackets. Set of 4. These fit A-18200 A and A-18200 B only. Raised area may need to shaved off	3.50
A-18200 SS	1930-31 Tension washer, original annular groove design (4 pc)	2.50
A-18300	Traffic light finder. Authentic reproduction for straight windshield cars of the 1920's and 1930's.	5.00

Windwing Glass

Brackets sold separately



A-18201 CE



A-18201 C

This is plain tempered safety glass with polished edges.

NUMBER	NAME OF PART	PRICE	NUMBER	NAME OF PART	PRICE
A-18201 A	1928-29 Roadster/touring	40.00	A-18201 DE	1928-29 Closed cars, etched	63.00
A-18201 AE	1928-29 Roadster/touring	63.00	A-18201 E	1930-31 Coupe/sedan, plain	42.00
A-18201 B	1930-31 Standard roadster/touring	42.00	A-18201 EE	1930-31 Coupe/sedan, etched	59.00
A-18201 BE	1930-31 Standard roadster/touring	Disc.	A-18201 F	1931 Victoria, plain	43.00
A-18201 C	1930-31 Deluxe roadster/touring	40.00	A-18201 FE	1931 Victoria, etched	Disc.
A-18201 CE	1930-31 Deluxe roadster/touring	57.00	A-18201 G	1931 Slant windshield sedan	41.00
A-18201 D	1928-29 Closed cars, plain	48.00	A-18201 GE	1931 Slant windshield sedan	Disc.
			A-18201 XX	Special order etched glass with rose bud design. Specify year and body style,	111.00

Accessory Radiator Caps, including Motormeters & Quails, Etc.

* Official Licensed Product
Official Motor Accessories



A-18352 AR
A-18352 B



A-18354 PR



A-18354 CW



A-18354 AR-PR
A-18354 B-PR



A-18354 AR-WR
A-18354 BR-WR



A-18355 C



A-18355 TQ



A-18355 U



A-18385 A
A-18385 AT
A-18385 B
A-18385 BT

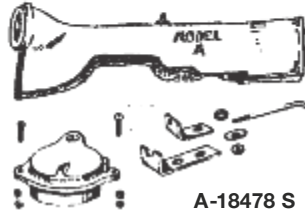

A-18478 S



A-18479



KEY FOB



A-18651



A-18650 OP

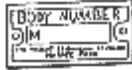

A-18652



A-18650

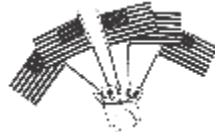

A-18356 FH



VAGABOND-L



VAGABOND-S

NUMBER	NAME OF PART	PRICE	NUMBER	NAME OF PART	PRICE
A-18352 AR	1928-29 Locking cap for motormeter	43.00	A-18360 BRK	1930-31 Locking cap repair kit	7.00
A-18352 B	1930-31 Locking cap for motormeter	43.00	A-18361 B	Motormeter lower black rubber gasket	1.00
*A-18354 AR PR	1928-29 Plain rim motormeter/locking cap	80.00	A-18361 R	Motormeter upper red fibre gasket	1.00
*A-18354 AR WR	1928-29 Wreath rim motormeter/locking cap	80.00	*A-18775	Decal, Ford oval magnetic & reflective	16.00
*A-18354 B PR	1930-31 Plain rim motormeter/locking cap	80.00	A-18385 A	1928-29 Flying Quail	71.00
*A-18354 BR WR	1930-31 Wreath rim motormeter/locking cap	80.00	A-18385 AT	1928-29 Thermo Quail, has thermometer mounted in center	79.00
*A-18354 CW	1928-31 Wreath rim motormeter	53.00	A-18385 B	1930-31 Flying Quail	71.00
*A-18354 PR	1928-31 Plain rim motormeter	53.00	A-18385 BT	1930-31 Thermo Quail, has thermometer mounted in center	79.00
A-18354 R	Motormeter repair kit	13.00	A-18478 S	1928-31 Manifold heater & valve	72.50
A-18355 C	Solid brass chrome plated wings (to be mounted with motormeter and locking cap) 8 inches	26.00	A-18479	1930-31 Firewall valve kit	9.95
A-18355 TQ	Replacement thermometer for the thermo quail	21.95	*A-18650	1928-31 Data/Patent Plate, with rivets	1.50
A-18355 U	Replacement thermometer for the motor meter	Disc.	A-18650 OP	1928-31 Plate, owners data plate	7.00
A-18356 FH	1928-31 Stainless steel bracket with flags. Fits under locking cap & motormeter	26.00	A-18650 R	Data Plate Rivets	1.25
VAGABOND L	Console for Model A (fits on floor around gearshift - long)	75.00	A-19225	1928-29 Heater door, cast iron. Fits contour of firewall.	Disc.
VAGABOND S	Console for Model A (fits on floor around gearshift - short)	57.00	A-18651	1928-31 Briggs data plate	1.75
			A-18652	1928-31 Murray data plate	2.00
			Key Fob	Specify year of car	2.25
			A-18070	Tool box mounts in front of radiator	175.00
			A-18362 MM	Upper motormeter gasket	1.00
			A-18810	Registration holder - Please specify color (Black, Brown, Green, Burgundy)	7.95

Novelty Items

NUMBER	NAME OF PART	PRICE
*30	Blue Ford Script Bean Bear 8-9" tall	7.00
A-18663	Wallpaper border 6" high, 15' long. Pre-pasted. Beautifully colored. Specify cars or trucks.	12.00 roll



A-18663 - Cars



A-18663 - Trucks

Stone Guards

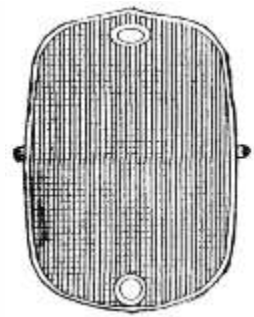

NUMBER	NAME OF PART	PRICE
A-18700 A	1928-29 Stainless steel stone guard	145.00
A-18700 B	1930 Stainless steel stone guard	145.00
A-18700 C	1931 Stainless steel stone guard	145.00
A-18750	1928-31 Stone Guard mounting kit	12.00

Spring Covers

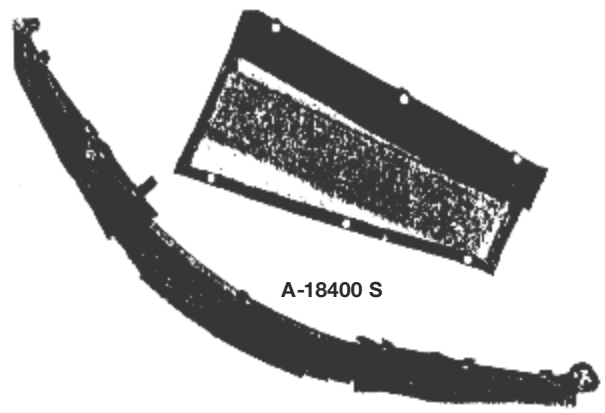

NUMBER	NAME OF PART	PRICE
A-18400 S	Spring covers. Exact duplicate of original	44.00

Luggage Rack



NUMBER	NAME OF PART	PRICE
A-17807	1928-31 Bumper Extender. Extends rear bumper behind luggage rack.	Disc
A-18575 BSS	1928-31 Stainless Steel luggage rack with wood slats. Two end brackets are steel painted black. Import chrome plated steel.	340.00
A-18575 I	Same as above w/wood strips. Import.	125.00
A-18576 AHD	1928-29 Luggage rack brackets	39.00
A-18576 AS	1928-29 Luggage rack adapter bracket (to adapt rack for use with rear-mounted spare)	9.00 pr.
A-18576 BHD	1930-31 Luggage rack brackets	37.00
A-18576 BS	1930-31 Luggage rack adapter bracket (to adapt rack for use with rear-mounted spare)	10.00 pr.
A-18595 EXT	Trunk rack brackets. Extended type for use with rear spares. Open and closed cars except Victoria.	57.00

Trunks



A-18574-8



A-18576 BS



A-18574

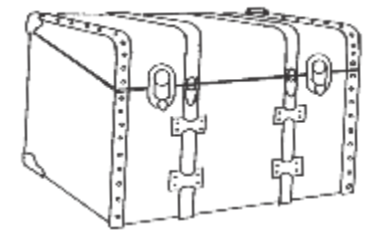

NUMBER	NAME OF PART	PRICE
A-18574 C	Black trunk for sedan back edge is arched to conform to the body	385.00
A-18574 BC	Trunk boot slips over trunk to protect it from the elements. Black. Fits coupe & sedan style trunks	77.00
A-18574 S	Black trunk for coupes and roadsters	385.00
A-18574-8	Locking Trunk latch. Nickel plated.	9.95
A-18574-9	Trunk to Luggage rack straps (black)	27.00 ea.
A-18574-10	Trunk to Luggage rack straps (tan)	27.00 ea.
A-18574 X	Special order trunk - Specify main color, trim color, & style	395.00

Note: Trunks may be ordered in tan also.
Due to recent UPS changes in classification of oversize packages this item will be shipped at the 70 lb. rate.

Luggage Rack Bolts (stainless)

NUMBER	NAME OF PART	PRICE	NUMBER	NAME OF PART	PRICE
A-18575 1	1 1/4 x 20 Acorn nut	.45	A-18575 4	3/8 - 16 x 1 Carriage bolt	.70
A-18575 2	1/4 - 20 x 3/4 Carriage bolt	.55	A-18575 5	3/8 - 16 x 1 Hex head bolt	.50
A-18575 3	3/8 - 16 x Acorn nut	.65			

Floor and Floorboards

* Official Licensed Product
Official Aftermarket Performance

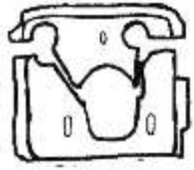

A-35122 S



A-35123 FP



A-35123 MB

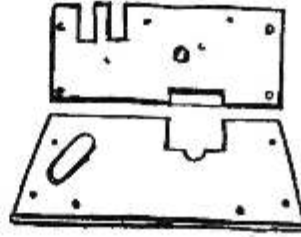

A-35130/31 AS A-35130/31 BS



A-35130/41 AS



A-35150 A

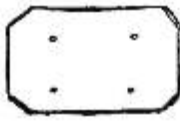

A-35150 B



A-35170 AS



A-35130/40 A

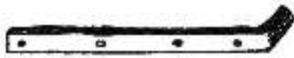

A-35202

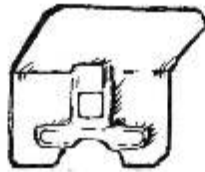

A-35245 BR



A-35245 C



A-80033



A-80034



A-35244



A-35246



A-35247

NUMBER	NAME OF PART	PRICE	NUMBER	NAME OF PART	PRICE
A-35122 S	1928-31 Metal cover plate for felt pads around steering column	5.95	A-35170 AS	1928-31 floorboard seal kit (order 1 kit per floorboard)	5.00
A-35123 FP	1928-31 Felt pad (Fits around steering column)	2.35	A-35202	Floorboard reinforcement strips	14.00 pr.
A-35123 MB	Cover plate mounting kit	1.25	A-35244	1928-31 Accelerator Grommet. Goes around accelerator post. Comes with tacks to nail on. Like the original.	.90
A-35129	1928-31 Tudor sedan storage box. Mounts under rear floorboard	130.00	A-35245 BR	1928-30 Shift lever plate, brake to front	5.00
A-35130/31 AS	1928-29 Front floorboards, EB to front	35.00	A-35245 C	1930-31 Shift lever floor plate	4.00
A-35130/31 BS	1929-31 Front floorboards, EB to right	35.00	A-35246	1928-31 Clip set for shift lever plate	2.50
A-35130/40 A	1928-31 Center tudor floorboard	40.00	A-35247	1928-31 Floor mat studs	5.50
A-35130/41 AS	1928-29 Rear floorboards, Tour & Tudor - Show	41.00	A-35249	1909-31 Carpet fasteners nickel - 2 pcs	1.50 set
A-35130/41 BS	1930-31 Rear floorboards, Touring & Tudor - Show	41.00	A-80033	1928-31 Front floorboard bolt and washer set	3.00 set
A-35130 AQ	1928-Early 29 Floorboards emergency brake in front of shifter	58.00	A-80034	1928-31 Rear floorboard bolt & washer set	3.50 set
A-35130 BQ	1929-31 Floorboards emergency brake to right of shifter	58.00			
A-35150 A	1928 Battery cover plate 4 1/8"	7.00			
A-35150 B	1929-31 Battery cover plate 5 1/2"	7.00			

Sheet Metal

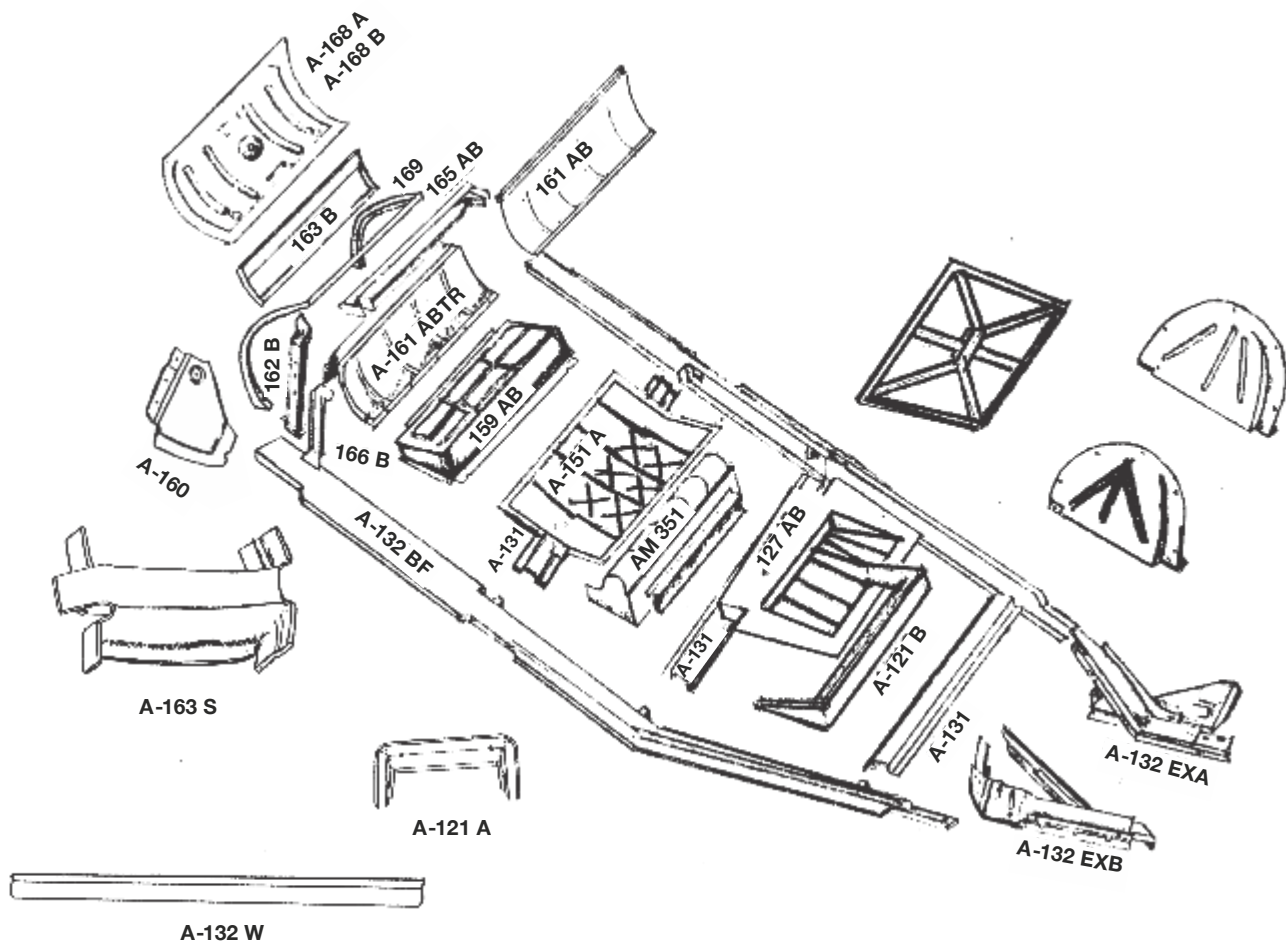

NUMBER	NAME OF PART	PRICE	NUMBER	NAME OF PART	PRICE
A-117 A	1928-29 Cowl cover - replaces gas tank	295.00	A-151 A	Trunk and rumble compartment angle floor pan; 1928-29 Coupes and 1928-31 Roadsters	75.00
A-117 B	1930-31 Cowl cover - replaces gas tank	295.00	A-158 AB	1928-31 Frame horns	55.00 pr.
A-121 A	Front seat platform, 1928-29 Roadsters and Phaeton	95.00	A-159 AB	Rumble seat platform, Coupe and Roadster	99.00
A-121 B	Front seat platform, 1930-31 Phaeton and Roadster	105.00	A-159 ABD	Rumble seat platform w/original design, best made	105.00
A-127 AB	1928-31 Roadster and Phaeton front seat curtain pan, fits under front seat	99.00	A-160	1928-31 Triangular pieces that fit on each side of the trunk compartment at the rear-curved inner panel fastens to these pieces.	77.00 pr.
A-129 B/125 B	1930-31 Roadster package tray mounting section (2 pcs)	135.00	A-161 AB	Curved inner panel below deck lid, 1928-31 Roadster, and 1930-31 Coupe with rumble seat	65.00
A-131	Body channels; these channels run across car between sub rails (we need the body style) 1928-31 All, except 1930-31 Coupe	80.00 set	A-161 ABTR	Curved inner panel below deck lid, Coupe and Roadster, without rumble seat. Trunk style cars	95.00
A-131 B	Body channels, 1930-31 Coupe only	80.00 set	A-162 A	1928-29 Rumble hinge brace	65.00 pr.
A-132 BF	1930-31 Roadster subrails, runs along side of body, Full length	325.00 pr.	A-162 B	1930-31 Rumble hinge brace	65.00 pr.
A-132 AF	1928-29 Roadster full length subrails	325.00 pr.	A-163 A	Outer panel below deck lid; 1928-29 Roadster 9-1/4" wide	70.00
A-132 B	1930-31 Roadster subrails, runs along side of body, rear half	225.00	A-163 B	Outer panel below deck lid; 1930-31 Coupes and Roadsters, panel has beads across bottom	70.00
A-132 A	1928-29 Roadster subrails, rear half	225.00	A-163 S	Fits behind the panel below the deck lid. Assists in supporting rear mount spare tire.	52.00
A-132 EXA	1928-29 Front subrail & floorboard extension. 4 pc. set	215.00 set			
A-132 EXB	1930-31 Front subrail & floorboard Ext. 4 pc. set	275.00 set			
A-132 W	Beaded panel below door on cars with wooden subrails	48.00			

Sheet Metal *(continued)*

* Official Licensed Product
Official Aftermarket Accessories



A-159 ABD

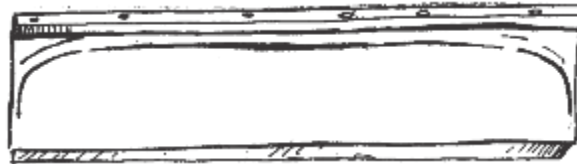

A-167 A
A-167 B



A-317 A

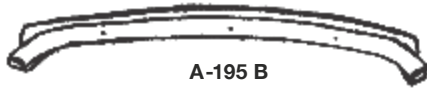

A-195 B

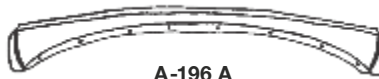

A-196 A



A-317 BS



A-321 A

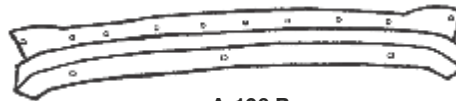

A-196 B

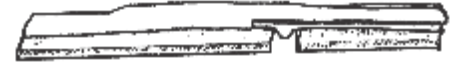

A-332 A
A-332 B



A-342



A-321 BASE



A-335 B

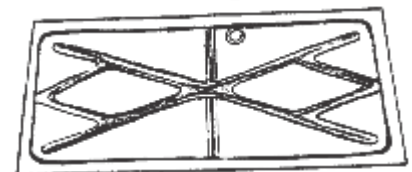

A-335 ADS

****NOTE: UPS NOW CHARGES 70 POUND RATE ON THESE ITEMS.**

NUMBER	NAME OF PART	PRICE	NUMBER	NAME OF PART	PRICE
A-165 AB	1928-31 Coupe & roadster heavy rear crossmember - goes on the end of the subrails - Below the deck lid panel fastens to it.	200.00	A-317 A	1928-29 Coupe & sedan sun visor	70.00
A-166 A	1928-29 Roadster front trunk or rumble compartment brace	65.00 pr.	A-80049	1928-29 Coupe and tudor sun visor mounting kit	3.00
** A-166 B	1930-31 Roadster & coupe front trunk or rumble compartment brace	65.00 pr.	A-317 BS	1930-31 Coupe, tudor & pickup steel sun visor, not 100% authentic, but will work	140.00
** A-167 A	1928-29 Roadster panel above deck lid	225.00	A-321 A	Front seat platform, 1928-29 sport and standard coupe and cabriolet	95.00
A-167 B	1930-31 Roadster panel above deck lid	225.00	A-321 B	1930-31 Coupe seat assy. Less track assy.	375.00
** A-168 A	1928-29 Rumble seat lid, all steel inner & outer panel. No latch or hinges	585.00	A-321 BASE	U-shaped piece that coupe seat assy. fastens to 1930-31	95.00
A-168 B	1930-31 Rumble seat lid, all steel inner & outer panel. No latch or hinges	585.00	A-332 A	1928-29 Coupe subrails, rear half	225.00
A-168 SK	1928-31 Deck lid skin only	275.00 ea.	A-332 AF	1928-29 Coupe full length subrails	325.00 pr.
A-169 A	1928-29 Coupe & roadster rain gutter that goes around trunk or rumble lid opening	265.00	A-332 B	1930-31 Coupe subrails, rear half	225.00
A-168 AT	1928-29 Coupe & Roadster trunk lid. All steel inner & outer panel. No latches or hinges	585.00	A-332 BF	1930-31 Coupe full length subrails	325.00 pr.
A-169 B	1930-31 Coupe & roadster rain gutter that goes around trunk or rumble lid opening	265.00	A-334	1928-29 Coupe panel under seat frame	60.00
A-168 BT	1930-31 Coupe & Roadster trunk lid. All steel inner & outer panel. No latches or hinges	585.00	A-335 ADS	1928-29 Coupe, roadster pickup, 1929 fordor phaeton, 1930-31 closed cap pickup die stamped panel under front seat	63.00
A-195 A	1928-29 Roadster dash rail.	210.00	A-335 B	1930-31 Coupe pan under front seat die stamped	90.00
A-195 B	1930-31 Dash rail for roadster, phaeton & pickup. All steel US made	290.00	A-342	1928-29 Tudor sedan & coupe header panel above windshield	80.00
A-196 A	1928-29 Dash reinforcement bar. Ties cowl post together.	125.00 ea.	A-366 A	1928-29 Coupe trunk or rumble compartment brace	65.00
A-196 B	1930-31 Dash reinforcement bar. Ties cowl post together.	125.00 ea.			

Sheet Metal *(continued)*

* Official Licensed Product
Official Aftermarket Replacement

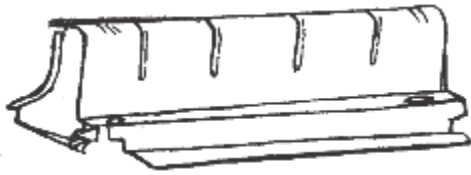

AM-350

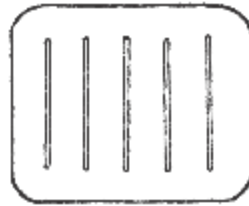

A-375 B

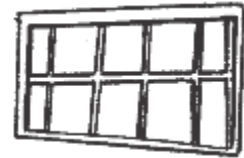

A-351 E
A-635 A

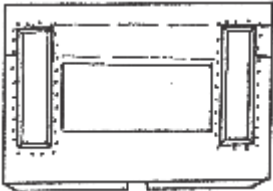

A-455 B



A-457 B

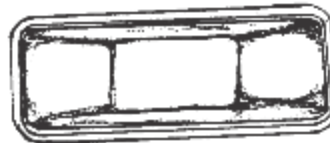

A-458

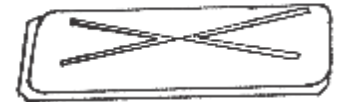

A-635 B



A-41000 U3
A-41000 U4

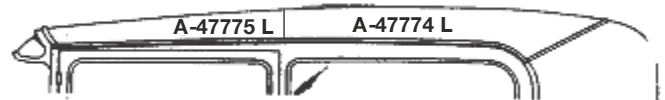

A-47775 L A-47774 L

NUMBER	NAME OF PART	PRICE	NUMBER	NAME OF PART	PRICE
AM-350	1928-29 Seat riser, coupe and roadster	90.00	A-619	1929 Cabriolet trunk & rumble floor pan	75.00
AM-351	1930-31 Seat riser, roadster only	95.00	A-635 A	1930 Cabriolet trunk flat floor pan 68-B	55.00
A-351 E	Flat floor pan behind front seat; 1930-31 coupes (only) (die stamped), used with or without rumble seat	50.00	A-635 B	1931 Cabriolet under seat pan. Also fits some late 1931 Coupes & SW (tapered 68-C)	55.00
AM-352	1930-31 Seat riser, cabriolet	95.00	A-727 A	Early 1928 Phaeton curtain pan fits under rear seat	90.00
A-361 A	AM-127 Curved inner panel below deck lid, 1928-29 coupes and cabriolets with rumble seat; also 1929-31 cabriolets	65.00	A-757 A	Rear seat frames, 1928-29 Touring, complete w/floor pan & hump	305.00
A-363 A	Outer panel below deck lid; 1928-29 Coupe 7-1/2" wide	70.00	A-1015 A	1928-29 Lower firewall	255.00
A-375 B	1930-31 Coupe metal roof top. Converts fabric top to all steel top. Crating fee to ship \$35.00	300.00	A-1015 B	1930-31 Lower firewall	295.00
A-432 A	1928-29 Tudor & phaeton subrails, rear half	225.00	A-1046	1928-29 Roadster & roadster pu door (left)	575.00
A-432 AF	1928-29 Tudor & phaeton full length subrails, also 1928-29 cc pu front	325.00 pr.	A-1046 B	1930-31 Roadster and roadster pickup left door	575.00
A-432 B	1930-31 Tudor & phaeton subrails, rear half	225.00	A-1047	1928-29 Roadster & roadster pu door (right)	575.00
A-432 BF	1930-31 Tudor & phaeton full length subrails	325.00 pr.	A-1047 B	1930-31 Roadster and roadster pickup right door	575.00
A-455 A	1928-29 Floor pan under tudor rear seat frame	75.00	A-41000 U1	Panel above windshield, 1929 town sedan & fordor sedan, behind visor	80.00
A-455 B	1930-31 Floor pan under tudor rear seat frame	75.00	A-41000 U3	Panel above windshield, 1930-31 coupe	80.00
A-457 A1	Rear seat frames, 1928-29 Tudor Sedan with hump panel	245.00	A-41000 U 4	Panel above windshield, 1930-31 tudor & pickup	80.00
A-457 B	Rear seat frames, 1930-31 Tudor Sedan with hump panel	245.00	A-47774 L	1928-31 Tudor rear roof panel drops 1" below gutter recess & 1" beyond rear moulding recess, left side	Disc.
A-458	Crossmember hump cover, stamped	75.00	A-47774 R	Same as above for right side	Disc.
A-465 AB	1928-31 Tudor & touring heavy rear crossmember - goes on the end of the subrails	200.00	A-47775 L	1928-29 Tudor curved roof panel above door, left	105.00
A-475 B	1928-31 Sedan metal roof top (crating fee \$50.00)	450.00	A-47775 R	1928-29 Tudor curved roof panel above door, right	105.00
			A-47776 L	1930-31 Tudor curved roof panel above door, left	135.00
			A-47776 R	1930-31 Tudor curved roof panel	

A Bodies

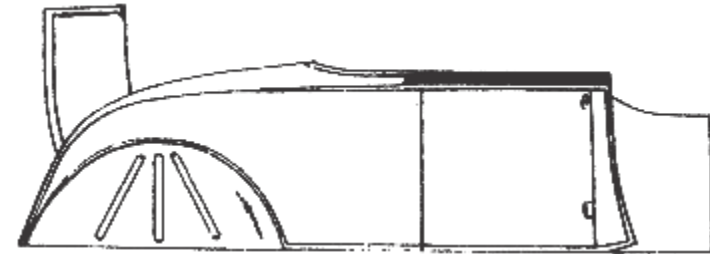

AF-100 A

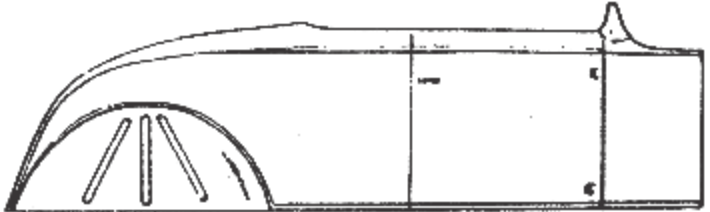

AF-100 B

NUMBER	NAME OF PART	PRICE
AT-100 A	1928-29 Roaster pickup cab - All steel, without gas tank. You mount your own original tank. Shipped FOB from factory	4,800.00
	Crating charge	300.00
AF-100 A	1928-29 Roadster body - All steel without gas tank. You mount your own original tank. Shipped FOB from factory	6,800.00
	Crating charge	500.00
AT-100 B	1930-31 Roadster pickup cab - All steel without gas tank. You mount your own original tank. Shipped FOB from factory	4,800.00
	Includes sub stanchions fitted to body	
	Crating charge	300.00
AF-100 B	1930-31 Roadster body - All steel without gas tank. You mount your own original tank. Shipped FOB from factory	6,800.00
	Includes sub stanchions fitted to body	
	Crating charge	500.00
AT-100 B Ext.	1930-31 Roadster -pickup extended cab. Cab extended 6 inches. Used with stock frame, fenders, splash aprons, etc. Includes sub stanchions fitted to body	5,100.00
	Shipped FOB from factory	
	Crating charge	300.00

Pickup Sheet Metal

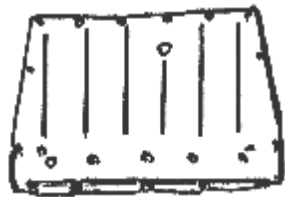

A-334 B



A-831 B



A-841



A-839



A-37639 APU



A-37639 BPU

NUMBER	NAME OF PART	PRICE	NUMBER	NAME OF PART	PRICE
A-334 B	1928-29 Closed cab pu curtain pan under seat panel with holes & beads pressed in	65.00 ea.	A-839	1930-31 Pickup rear roof wood bracket. Connects side wood rail above door to the door post. 2 needed	11.25 ea.
AM-579	1928-31 Pickup panel between cab and bed	45.00	A-839 BT	1930-31 PU rear roof wood bracket bolt kit	2.75
A-817 A	1928-29 Closed cab pickups sun visor & 1926-27 Closed car, coupe & tudor.	95.00	A-841	1928-29 CC PU header panel above windshield	80.00
A-817 VK	1928-29 Closed cab pickup visor cover kit, black cobra material, complete	65.00	A-850 B	1930-31 closed cab pickup lower patch w/bead	60.00
A-821 A	1928-29 Closed cab pickup seat frame	85.00	A-875 T	1928-29 Closed cab pickup cat "T" strip	54.00
A-821 A1	1928-29 Roadster pickup seat frame	85.00	A-890	1928-29 Closed cab mail pouch - pair	23.00
A-821 B	1930-31 Closed cab pickup seat frame	85.00	A-972 AB	1928-31 Pickup bed metal center pan	32.50
A-828	1928-29 Closed cab pickup corner patch panels	340.00 pr.	AWD-1225	Narrow bed pickup wood for floor of of bed	250.00
A-830	1928-29 Closed cab pickup, window panel, die stamped	245.00	A-37639 APU	1928-29 Closed cab pickup inside rear window frame	32.00 ea.
A-831	1929 Pickup bottom rear closed cab panel, Die stamped	225.00	A-37639 BPU	1930-31 Closed cab pickup inside rear window frame	82.00
A-831 B	1930-31 Pickup closed cab rear cross-member	76.25	A-47776 PL	1930-31 Pickup left curved roof panel	150.00
A-821 BI	1930-31 Roadster PU seat frame	85.00	A-47776 PR	1930-31 Pickup right curved roof panel	150.00
A-836 ESL	1928-29 Closed cab pickup door skin left	103.00			
A-836 ESR	1928-29 Closed cab pickup door skin right	103.00			

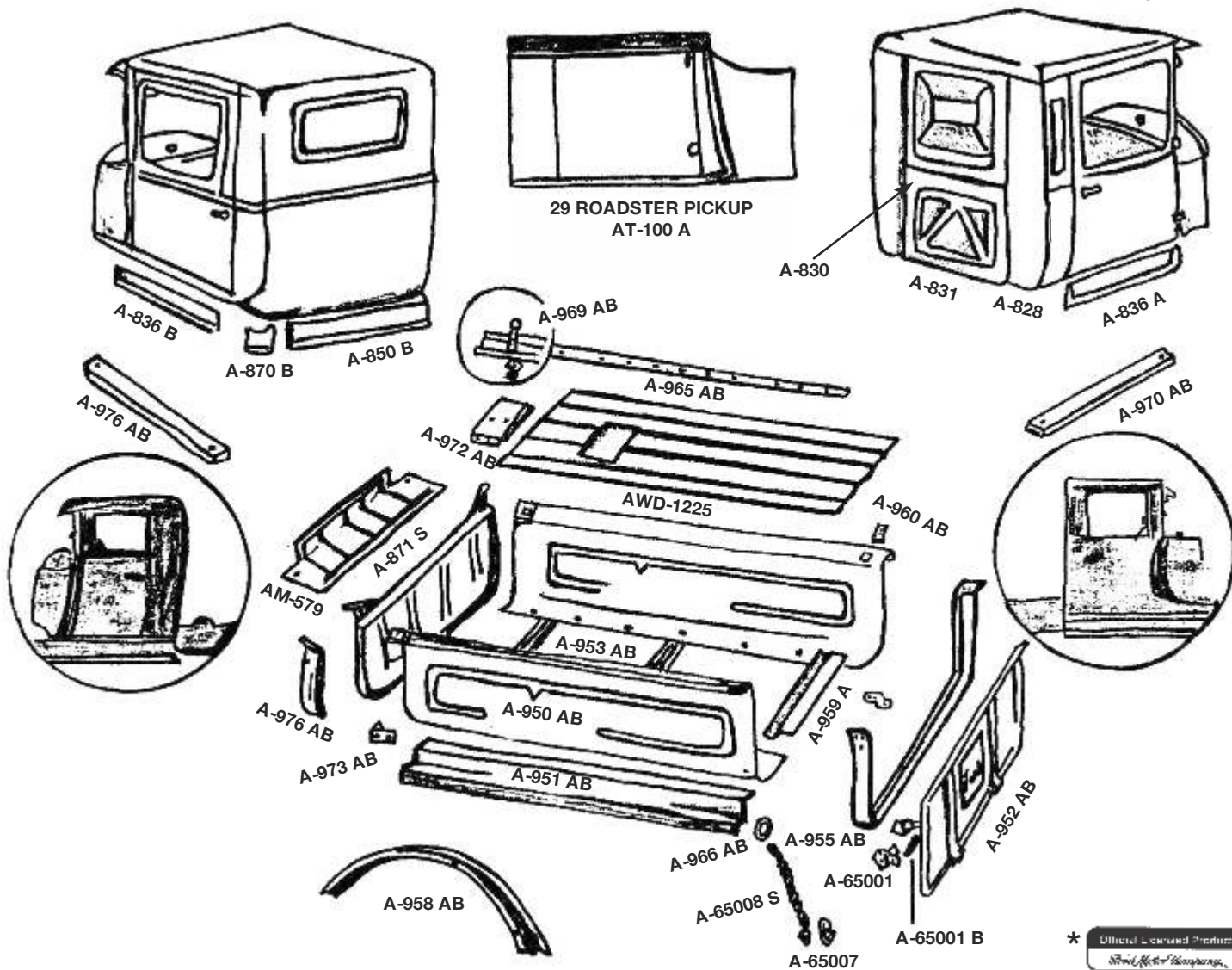

* Official Licensed Product
 Official Aftermarket Components

28-31 A Pickup Beds

NUMBER	NAME OF PART	PRICE	NUMBER	NAME OF PART	PRICE
A-870 B	1930-31 Closed cab pickup rear corner patches	35.00 pr.	A-960 AB	1928-31 PU bed front stake pocket reinforcement plates (4 pc. set)	28.00 set
A-871 S	Front bed panel with top corner bracket spot welded on it.	125.00	A-965 AB	1928-31 PU bed strips with prepunched holes (set of 4)	59.00 set
A-874	1928-31 Pickup bed rear cross member patch, used to repair bottom of u channel	45.00	A-965 ABS	1928-31 PU bed strips with holes prepunched out of stainless steel (set of 4)	85.00 set
A-950 AB	1928-31 PU bed sides only no attaching parts	580.00 pr.	A-970 AB	1928-31 PU bed sills, these are the hardwood pieces that go between bed & frame	67.00 pr.
A-951 AB	1928-31 PU bed subrails. These are heavy support rails where wood mounting bed sill goes	215.00 pr.	A-971 AB	PU bed rivet kit	10.00
*A-952 AB	1928-31 PU tail gate, has all brackets for mounting	275.00	A-972 AB	1928-31 Pickup bed center pan	32.50
A-953 AB	1928-31 PU bed cross channels, these are the two support channels that run crossways in bed.	99.00 set	A-972 ABS	1928-31 Pickup bed center pan - stainless	40.00
A-955 AB	1928-31 PU u channel this is the part that the rear tail gate brackets hook to, it is also rear stake pockets	265.00	A-973 AB	Metal brackets that hold wooden subrails in to bed	46.00 pr.
A-958 AB	1928-31 Rear fender spacers that go between bed and the rear fenders	135.00 pr.	A-975 AB	1928-31 Model A pickup bed. This is a complete bed with tailgate. Just paint it and bolt to frame. Shipped FOB.	1,675.00
A-959 A	Z-Shaped channel that goes on top of rear u channel	30.00		Crating Charge	300.00
			A-975 AB EXT	Roadster pickup bed. Used only with extended roadster pickup body.	1,900.00
				Crating Charge	300.00
			A-975 BT	1928-31 Pickup bed to frame bolt set	5.25 set
			A-976 AB	Front stake pockets for a pickup bed	85.00 pr.

Rumble Seat Parts

* Original Licensed Product
Ward Motors Company

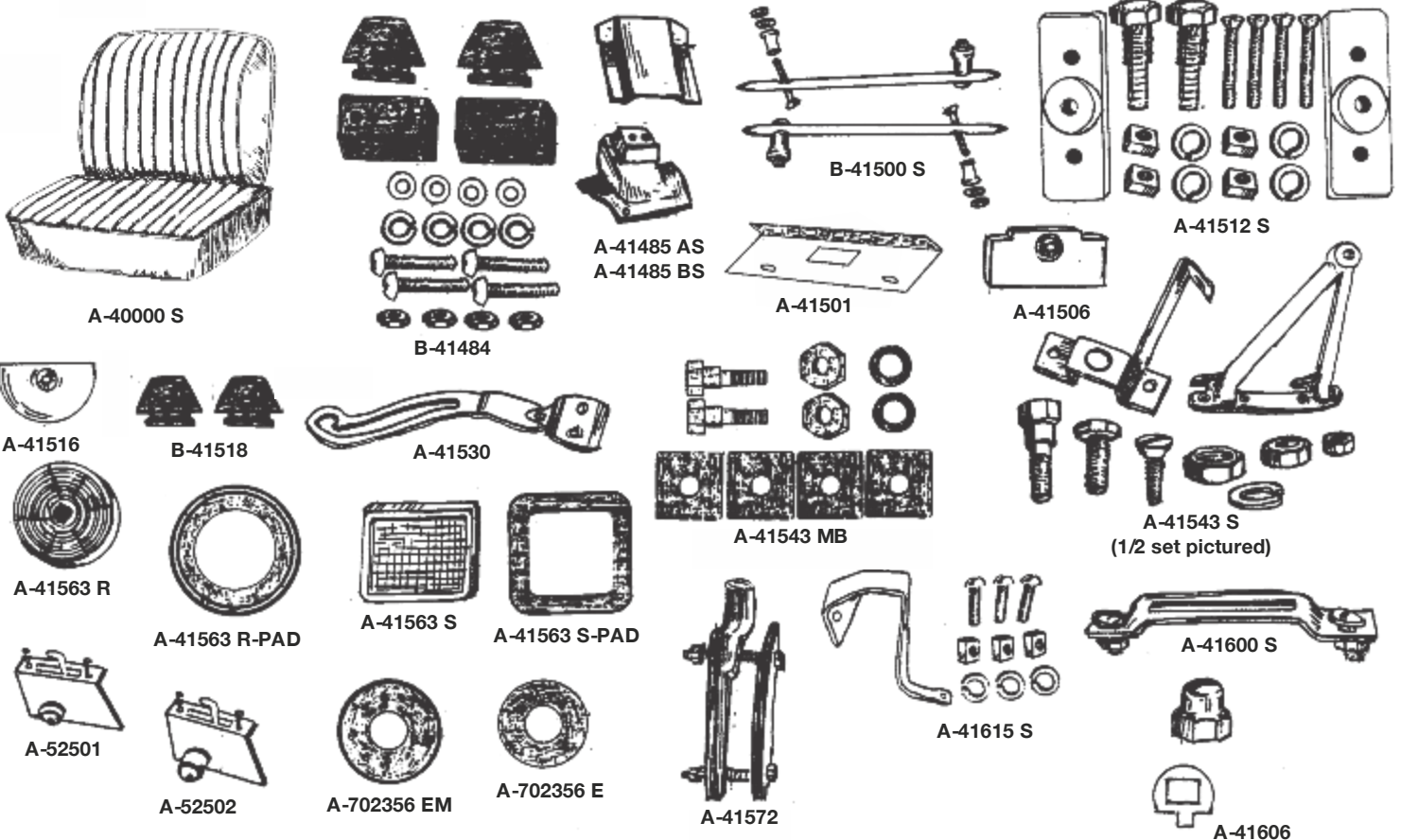

NUMBER	NAME OF PART	PRICE	NUMBER	NAME OF PART	PRICE
A-40000 FC	1928-31 Black vinyl with sponge backing fender cover keeps passengers from scratching car when getting in or out of rumble seat		A-41530	Deck lid support assembly, 1928-32 coupe & roadster w/o rumble seat	16.95 ea.
A-40000 S	1928-31 Rumble seats, unholstered in black with wide pleats, ready to install	14.00	A-41530 ND	New design deck lid support (correct fit)	27.00
B-41484	1928-34 Rumble lid bumper kit	2.95	A-41543 MB	Rumble hinge pivot bolt kit	5.00 set
A-41485 AS	1928-29 Rumble lid stop kit, Inc. stops, platform supports and bumpers	14.95	A-41543 S	1928-31 Rumble seat hinge kit (Complete Set)	26.50
A-41485 ASE	1928-29 USA Mfg. Rumble lid stop kit	60.00	A-41563 R	Late 29-31 round aluminum step plate	6.00
A-41485 BS	1930-31 Rumble lid stop kit, includes stops platform supports and bumpers	14.95	A-41563 R-PAD	Moulded rubber pad, round	2.00
A-41485 BSE	1930-31 USA mfg. Rumble lid stop kit.	60.00	A-41563 S	1928-29 Aluminum step plate with mounting bolt, square, used until Feb. 1929	9.25
A-41500 BT	Grab handle mounting bolt kit (included in A-41500 S)	1.75	A-41563 S-PAD	Moulded rubber step plate pad, square	2.25
A-41500 S	1928-31 Roadster rumble seat grab handles, chrome	31.00	A-41572	Rumble step plate, rear bumper bracket (cast iron)	6.95
B-41500 S	1928-32 Stainless steel rumble seat grab handles	43.50 pr.	A-41572 A	1928-29 Step plate bracket	37.00
A-41501	1928-31 Rumble grab handle support plate. Mount under quarter panel to provide support for B-41500 S	25.20 pr.	A-41600 S	Rumble striker plate	2.40
A-41506	1928-31 Rumble seat lid alignment plates, rectangular	3.75 pr.	A-41606	Original type rumble lid locking handle, acorn nut and lock washer	1.50
A-41512 S	Deck lid hinges for cars with trunks.	50.00	A-41615 S	1928-31 Coupe and roadster trunk lid striker plate	6.50
A-41516	1928-31 Trunk lid alignment plates (for cars w/trunk only) half round	5.25 pr.	A-52501	1928-31 Trunk lid latch. 1" tall. 1928-29 Rumble lid latch. Import	12.95
B-41518	1928-34 Rubber bumpers for the upper corner of rumble lid and floor lower corners of deck lid.	1.75 pr.	A-52501 AX	1928-29 Coupe & Roadster rumble latch 1928-32 Trunk latch	29.75
			A-52502	1930-31 Rumble lid latch. 1 1/2" tall. Import	12.95
			A-52502 BX	1930-34 Roadster & 1930-32 5 window Coupe rumble latch, 1932 3 window Coupe, 1933-34 Roadster & Coupe Trunk latch	29.75
			A-702356 E	Deck lid handle, grommet (fiber)	.50
			A-702356 EM	Moulded rubber deck lid, handle grommet	2.25
			A-41530 MB	Deck lid support slide bolt kit	3.75

Top Parts



PART NUMBER	ALUMINUM MODEL A TOP MOULDINGS		
	MOULDING TYPE	LOCATION	APPLICATION (BODY STYLE)
A-47302-1	Style #1 Extruded Aluminum Flat bottom 5/8 inch wide	Front	Coupes: 45-B Sedans: 155-A,B,C,D; 165-A,B,C,D; 170-A,B Victoria: 190-A (Additions) 5 ft. piece, straight see original 13.95 ea.
A-47302-2	Style #2 Extruded Aluminum Flat bottom 1/2 inch wide	Front	Tudor: 55-B (Additions) see original Sedans: 160-A,B,C Commercial: 82-B; 130-B 5 ft. piece, straight 13.95 ea.
A-47302-3	Style #3 Extruded Aluminum Ribbed bottom 5/8 inch wide	Sides and/or Rear	Coupes: 45-B before 5/31 (Additions) see original Sedans: 155-A,B,C,D; 165-A,B,C,D; 170-A,B 10 ft. Coil 27.00

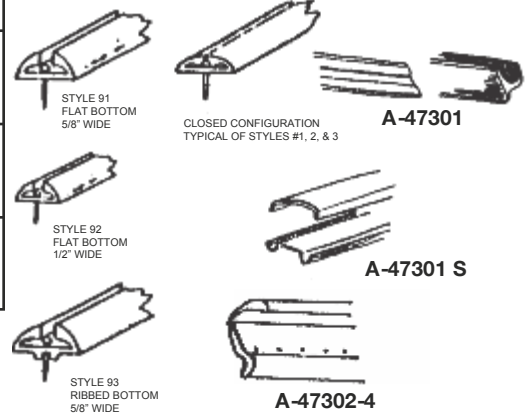

**** NOTE:** (1) Other body styles may have used this moulding depending on assembly line stock fluctuations.

(2) Late 1931 all steel cabs used no front moulding.

See explanation for body style numbers on page 147.

****Due to recent UPS changes in classification of oversize packages this item will be shipped at the 70 lb. rate resulting in minimum shipping charge of \$20.00 and higher.**

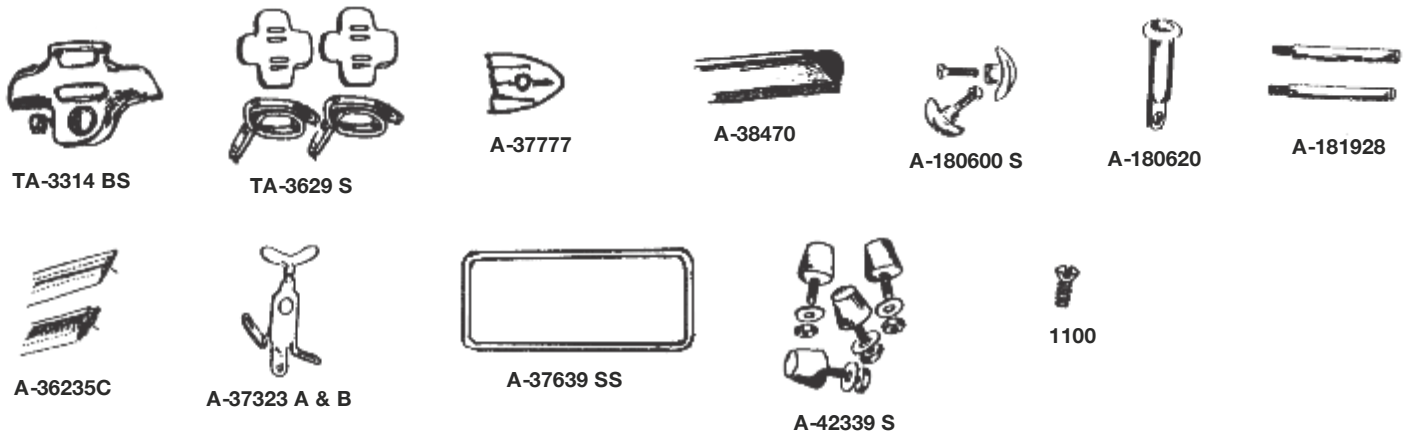

NUMBER	NAME OF PART	PRICE	NUMBER	NAME OF PART	PRICE
TA-3314 BS	1924-29 Top saddle	18.00 pr.	A-37323 B	1930-31 Std. Roadster - touring top hold-down clamps	52.00 pr.
TA-3629 S	1924-29 Top saddle leather pads & straps	16.00 set	A-37639 SS	Window frame, rear - outer S/S for deluxe cars 7" x 16 1/2"	179.95 ea.
A-37777	Hydem welt tips roadster phaeton. 4 required	.50 ea.	A-37639 PL	1928-31 Plain steel rear window frame. Open car 7" x 16-1/2"	160.00
A-37777 V	1930-31 Hydem welt tips victoria	.50 ea.	1100	1928-31 Open car rear window screw set (16 pieces)	1.75 set
A-38470	Rubber insert for top moulding for May 1931 coupe and sedans 160 ABC and 1930-31 victoria fits in B-705019	7.95	A-42339 S	1928-31 Roadster top back window frame bumpers	3.25 set
A-180600 S	Roadster top bow "T" bolts	10.00 pr.	A-47300	Black topcoat dressing for water proofing and finishing old top	18.50
A-180620	1931 Deluxe open car side curtain rod socket	8.50 ea.	**A-47301	1928-31 Aluminum 2-pc. snap-on rain gutter. Must be bent to contour of the roof.	21.95 set
A-181928	1928-29 Top saddle studs, stainless steel - fordor phaeton	23.00 pr.	A-47301 S	1928-31 Tudor & pickup, 1928-29 coupe, 1929 special coupe, 1928-29 taxi 2-piece style steel top moulding. Correct dome shape on upper piece. 6 ft. length can be used front and rear	15.50
A-36235 C	Hydem welt not original but can be used in place of crown moulding	.75 foot	A-47302-4	Style #4. Extruded aluminum groove on bottom. Used on sedans 160 A/B/C 5 ft. length.	13.95
A-37323 A	1928-29 Roadster and touring top hold-down clamps	52.00 pr.			

Miscellaneous Top Parts

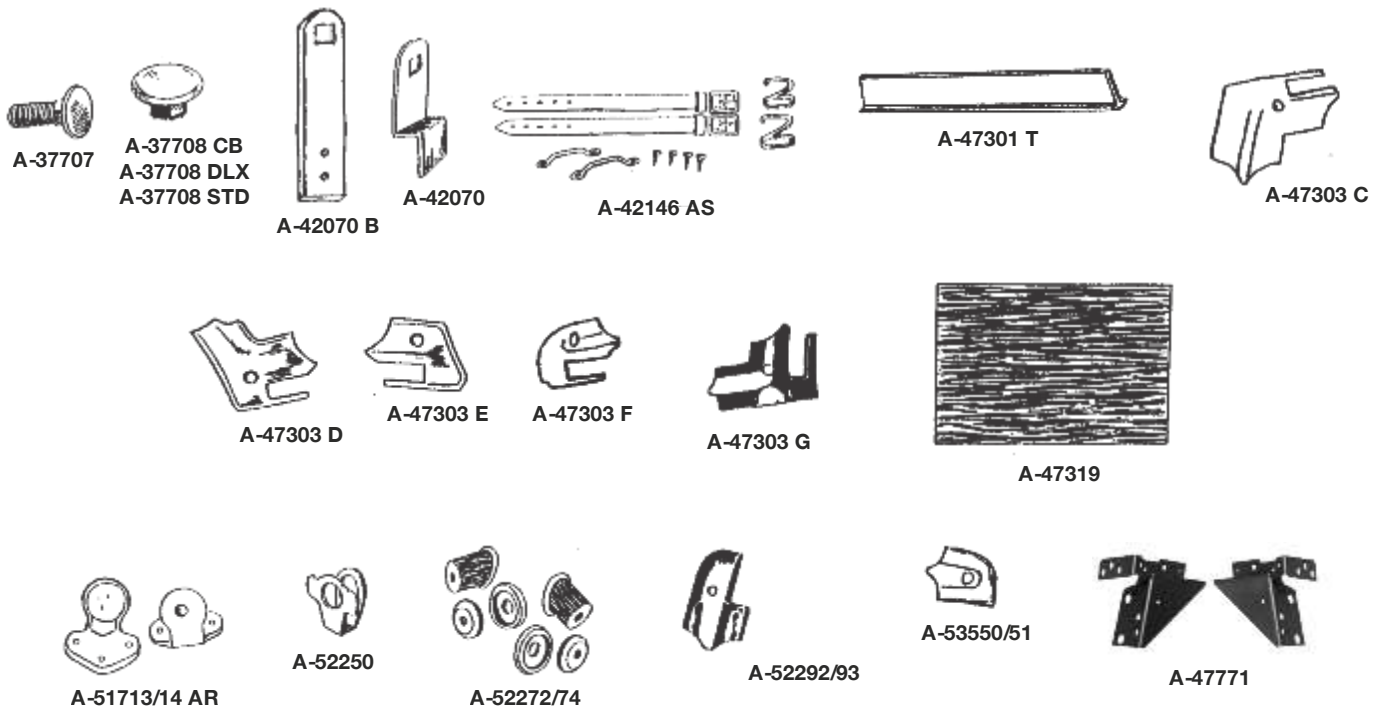

NUMBER	NAME OF PART	PRICE	NUMBER	NAME OF PART	PRICE
A-37707	1928-31 Standard roadster & roadster pickup top prop bolt.	.50	A-47303 F	Goes on rear of drip rails on 1928-29 Briggs	5.00 pr.
A-37707 SS	Top prop knob bolt, stainless steel polished	1.30 ea.	A-47303 G	1928-31 Tudor rear roof drip moulding tips.	5.00 pr.
A-37708 CB	1930-31 Die formed s/s, 1-7/8" diameter cabriolet	9.75 ea.	A-47304	Wire on hydrem welting	.75 ft.
A-37708 DLX	1930-31 Die formed s/s, 1-1/2" diameter	7.50 ea.	A-47319	Top material - long grained 65" wide. Coupes require approximately 5 feet, Sedans approximately 7 feet.	4.75 ft.
A-37708 SP	1928-31 Sport coupe prop nut 3/8" fine thread	7.75 ea.	A-51713/14AR	1928-29 Sport coupe landau arm bracket, fits inside on wood.	60.00 pr.
A-37708 STD	1924-31 Die formed, 1-1/2" diameter steel, cadmium plated, to be painted.	6.25 ea.	A-51881	1928-29 Sport, Special or Business Coupe 1" wide belt rail moulding.	Disc.
A-42070	1928-29 Open car top bracket, mounts top	9.50 ea.	A-52250	Prop nut lock washer	1.65
A-42070 B	1930-31 Open car top bracket, mounts top	9.50 ea.	A-52270 S	1928-31 Sport coupe landau arm stud set	11.25
A-42146 AS	1928-31 Roadster top prop rest and hook set.	35.50	A-52272/74	Sport coupe landau arm spacer, with black long grain material & four 1-1/2" washers.	64.95 set
A-47301 T	T-strip fits between body panels, straight aluminum	43.95 pr.	A-52292/93	Used on the rear of the door rail on a 1928-31 sport coupe and 1928-29 business coupe.	5.25 pr.
A-170 ST	T-strip between quarter panel and back panel on 28-31 Sedans, steel	44.00 ea.	A-53550/51	Used on the front of the drip rails on 1928-29 sport and business coupe.	5.25 pr.
A-47303 C	1928-29 Briggs front of roof drip moulding tips.	6.00 pr.	B-705019	Top moulding. Late 1931 Coupe, 31 Sedan, 160 A, B, C, and Victoria. 70" long. Needs 2 for coupe, 3 for Sedan	Disc.
A-47303 D	1928-29 Coupe and tudor. Used on left/right front drip rail moulding.	5.00 pr.	A-47771	1930-31 Front roof corner brackets (ties header to side rail) Tudor and closed cab	67.75
A-47303 E	Clips go on at the rear and finish off gutters on 1928-29 coupe and 1928-29 special coupe.	5.00 pr.			

Windshield & Stanchions & Fasteners

* Official Licensed Product
Wind Motor Company

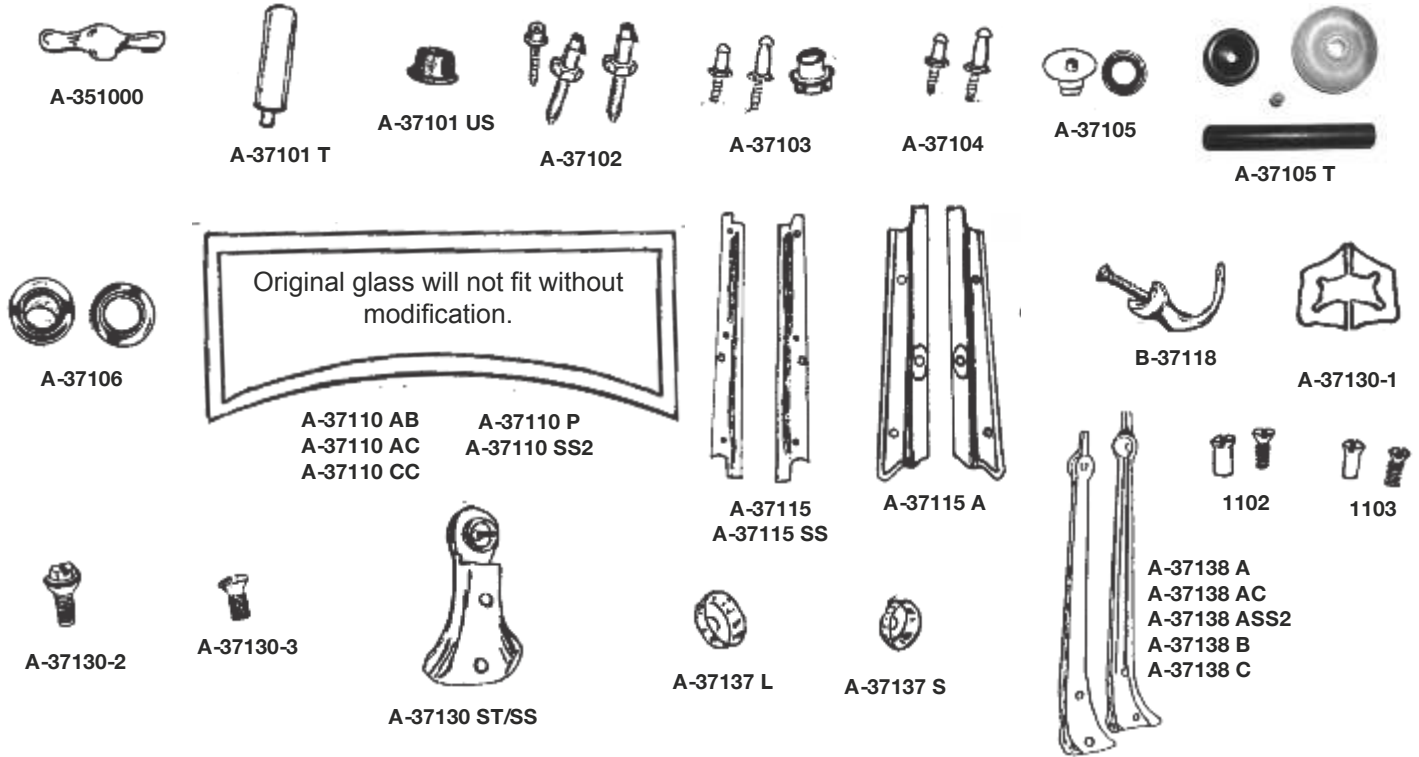

NUMBER	NAME OF PART	PRICE	NUMBER	NAME OF PART	PRICE
1102	1931 Slant windshield door frame tube nut set (10 pieces). 8/32	4.75 set	A-37115 A	1928-29 Closed car windshield garnish moulding	48.00
1103	Door frame tube nut & screw Briggs straight windshield cars (6 pieces). 6/32	3.75 set	A-37115 SS	1930-31 Same as A-37115, stainless steel	49.00
1140	Closed car windshield hinge & frame screws	2.25	A-37115 SW	1931 Slant windshield garnish moulding, 4-door	49.00
1141	Closed car windshield frame screws	1.50	A-37115 MB	1930-31 Garnish moulding screws. 6 pc. used with A-37115, stainless steel	2.00
A-351000	Windshield wing nut	2.75	B-37118	1928-31 Finger pull w/screw	9.75 pr.
A-37101 T	Curtain body socket tool	2.00	B-37118 SC	1928-31 Finger pull stainless steel screws	.80 pr.
A-37101 US	Side curtain body socket USA made, better quality	5.00 ea.	A-37130-1	1930-31 Open car stanchion spacer (2)	8.00 set
A-37102	Roadster tack rail fasteners, fastens top to body, Fits: 1928-31 roadster, 1928-29 roadster pickup, set of 11	27.00	A-37130-2	Late 1931 stanchion mounting screws, special head, set of 4	5.00 set
A-37102 DBL	Double length nickel stud 8/32 for lift-a-dot	.95	A-37130-3	1928-29 Stanchion oval head mounting screws coarse thread, set of 4	2.00 set
A-37102 T	1930 Roadster truck tack rail fastener kit	33.00	A-37130-4	1930-31 Stanchion mounting screws, oval head, fine thread, set of 4	3.00 set
A-37103	1928-31 Open car fasteners that attach top to windshield frame, set of 18	17.50	A-37130 ST	1930-31 Open car sub stanchion for standard or deluxe cars. Lower stanchion that bolts to body	125.00 pr.
A-37104	1928-35 Roadster, phaeton windshield post curtain studs, set of 12	12.50 set	A-37130 ST/SS	1930-31 Open car sub stanchion for standard or deluxe cars. Lower stanchion that bolts to body (stainless steel)	250.00 pr.
A-37105	1928-31 Male side curtain fastener. Fits on side curtain.	7.40 ea.	A-37137 L	1926-31 Large windshield post socket	6.75
A-37105 T	Side curtain fastener tool. Use to fasten A-37105 on side curtains.	16.50	A-37137 S	1926-31 Small windshield post socket	6.50
A-37106	Cinch eyelet & washer grommet ring	.95 ea.	A-37138 A	1928-29 Stamped steel windshield stanchion post for roadster, phaeton, and roadster pickup	195.00 plain
A-37110 AB	1928-29 Plain roadster or phaeton windshield frame	245.00	A-37138 AC	Stainless steel, Same as A-37138 A	245.00
A-37110 AC	1928-29 Chrome Roadster or Phaeton windshield frame	425.00	A-37138 ASS2	Stamped stainless steel windshield post stanchion for roadster & roadster pu. Chopped 2"	245.00
A-37110 CC	1930-31 Chrome deluxe roadster or phaeton windshield frame	425.00	A-37138 B	1930-31 Deluxe roadster windshield stanchion (complete). Identical to original	210.00
A-37110 P	1930-31 Plain standard roadster or phaeton windshield frame	245.00	A-37138 C	1930-31 Standard roadster windshield stanchion (complete). Identical to original.	280.00
A-37110 PC	1930-31 Std. windshield frame. Chrome	425.00	A-37138 CP	1930-31 Std. Roadster windshield stanchions, plain steel	250.00
A-37110 SS2	Stainless flat roadster windshield frame. Chopped 2"	475.00			
A-37115	1930-31 Windshield garnish moulding except slant w/s	36.00 pr.			

Windshield (continued)

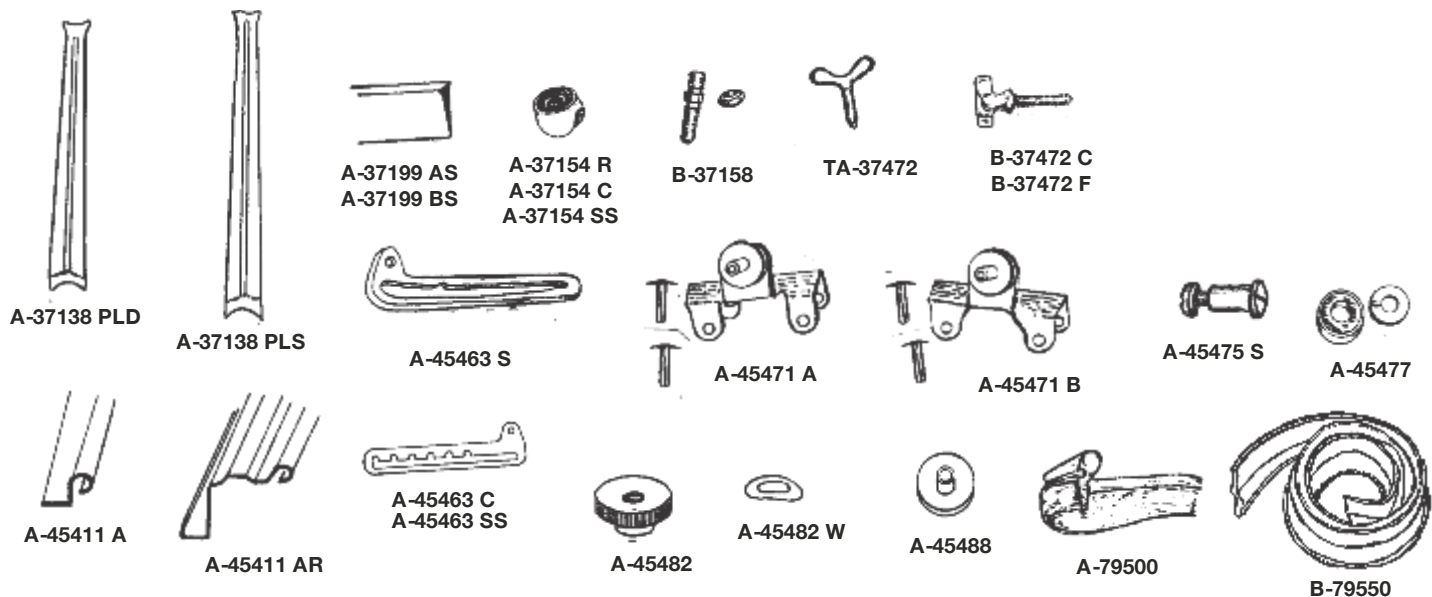

NUMBER	NAME OF PART	PRICE	NUMBER	NAME OF PART	PRICE
A-37138 PLD	1930-31 Stanchion post liners (deluxe open car) (2 required)	12.35 ea.	A-45411 A	1930-31 Windshield hinge	12.00
A-37138 PLS	1930-31 Stanchion post liners (standard open car) (2 required)	22.50 ea.	A-45411 AR	1928-29 Windshield hinge	12.00
A-37154 C	Chrome windshield frame cone	5.65 ea.	A-45463 C	1925-31 Chrome windshield swing arms with Positive stops over 3/4"	18.00 pr.
A-37154 R	1928-31 Windshield frame cone, plain	5.45	A-45463 S	1925-31 Windshield swing arms, original style	9.75 pr.
A-37154 SS	1928-31 Windshield frame cone, stainless steel	6.00	A-45463 SS	1925-31 Closed car windshield swing arms. Satin finished stainless steel with positive stops over 3/4".	26.00 pr.
B-37158	1922-36 Roadster phaeton windshield pivot stud and special cone nut (2 studs and nuts) Duplicate of original.	5.50	A-45471 A	1928-29 Closed car windshield frame bracket	9.95 ea.
A-37170	1928-31 Original style windshield curtain snaps.	1.65 ea.	A-45471 B	1930-31 Closed car windshield frame bracket	9.95 ea.
A-37171	1928-31 Replacement screw in style curtain snaps.	.65 ea.	A-45471 SW	1930-31 Slant windshield hinge bracket.	14.75
A-37172	Snaps 1/8" screw type for windshield frame to top. Set of 6	2.75 set	A-45475	1930-31 Windshield swing arm screws used with insert type bracket	.75
A-37199 AS	1928-29 Windshield rubber, open car	4.50	A-45475 S	1928-29 Windshield slide arm mounting screw and special tube nuts	1.75 pr.
A-37199 BS	1930-31 Windshield rubber, open car	4.50	A-45477	1928-31 Windshield slide arm washers	2.25 pr.
TA-37472	Wing nuts for top hold-down clamps	5.25	A-45482	1928-31 Windshield slide knobs	7.00 pr.
B-37472 C	1930-31 open car thumb screw 5/16" N.C.	4.75	A-45482 W	1928-31 Closed car swing arm pivot spring washer, 4-pc. set	1.50 set
B-37472 F	1928-29 open car thumb screw. Fine thread 5/16" N.F.	4.75	A-45488	1928-31 Closed car windshield press in pivot. (Steel nut A-45475 S pivots in this nut)	1.45
A-45410 A	1930-31 Aluminum, tudor, coupe, pu and fordor windshield frame. Close duplicate of original w/hinge.	240.00	A-79500	1926-31 Closed car windshield rubber (sides and bottom)	3.60
A-45410 AR	1928-29 Aluminum tudor, coupe, pu & fordor windshield frame. Close duplicate of original w/hinge.	240.00	A-79501	Aluminum windshield gasket rubber	3.95
A-45410 E	1931 Victoria & slant windshield aluminum frame w/hinge	240.00	A-79500 SW	1931 Slant windshield gasket sides and bottom	30.00
			B-79550	1928-32 Windshield hinge gasket	2.75

Filler Trim

NUMBER	NAME OF PART	PRICE	NUMBER	NAME OF PART	PRICE
BWO-3031 L	1930-31 Closed car panel between windshield & gas tank. Fits against windshield bottom. Good quality fiberglass.	105.00	BWO-3031 LV	Same as closed car. Fits Victoria. Fiberglass.	155.00
BWO-3031 S	Same as above. Made of steel.	185.00			

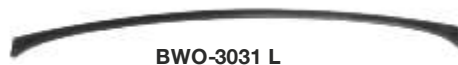

BWO-3031 L

Window Regulator and Glass Channel and Weatherstripping

* Official Licensed Product
 Wind Motor Components

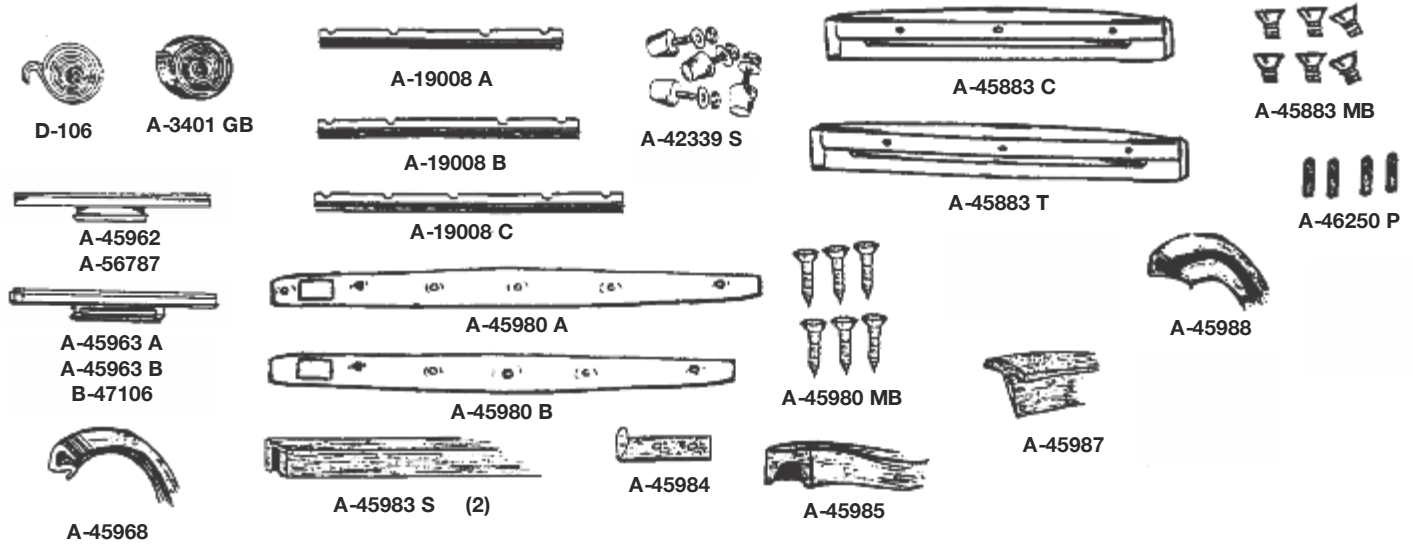

NUMBER	NAME OF PART	PRICE	NUMBER	NAME OF PART	PRICE
D-106	Window regulator spring	9.00	A-45962 SW	1931 slant windshield fordor metal glass channel. Left side.	38.00 ea.
A-3401 GB	Glass bed channel, mounts glass in window channel, 10 ft	7.50	A-45962 SWR	1931 Slant windshield fordor metal glass channel. Right side.	38.00 ea.
A-3401 X	Rubber glass bedding 3/64" thick - 10 ft	5.50	A-45962 VR	1931 Victoria glass channel. Right side	38.00 ea.
<p>"T" Rubber anti rattler, complete with aluminum mounting bracket. Fits under inside door moulding and rests against glass. Aluminum bracket replaces the old metal bracket which is sometimes rusted and in too poor condition to accept the new "T" rubber.</p>			A-45962 VL	1931 Victoria glass channel. Left side.	38.00 ea.
A-19008 A	1928-29 Coupe, 1928-31 tudor front, 1930-31 Pickup upper door seal. Fits under garnish molding	9.00 pr.	A-45963 B	Metal glass channel, L.H. fordor. Both doors are the same	10.50
A-19008 B	1930-31 Coupe upper door seal. Fits under garnish molding.	9.00 pr.	A-45968	Door glass to body seal, w/lip, 6 ft. Used on bottom of door glass for slant windshield cars.	7.50
A-19008 C	1928-31 Tudor rear window seal. Fits under garnish molding.	9.00 pr.	A-45980 A	1928-31 Door opening header strips Fits in door opening above door. Fits standard coupe, tudor, special Coupe, 6 hole, except 1930-31 cp.	30.00 pr.
A-19008 4DF	1928-31 Fordor front upper door seals.	14.00	A-45980 B	1930-31 Door opening header strips. Fits in door opening above door. Fits coupe. 5 hole.	30.00 pr.
A-19008 4DR	1928-31 Fordor rear upper door seals.	14.00	A-45980 MB	Door opening header strip mounting screws	1.25 set
A-19008 R	T-Rubber for upper door seals - Anti rattle under inside moulding. 1 per door. Fits aluminum only	1.25	A-45983 S	Felt glass run channel - 1 door	21.00 pr.
A-42339 S	1928-31 Roadster top back window frame bumpers	3.25 set	A-45983 SW	Felt glass run channel front doors of slant windshield fordor. and Victoria	61.00 set
A-45883 C	1930-31 Coupe door top cover plate	57.00 ea.	A-45984	Bracket for felt channel - 6 pcs. One set required per channel	1.00 set
A-45883 MB	Door top cover plate strip mounting screws	1.00 set	A-45985	Top window sponge, closed cars	2.25
A-45983 PU	1928-29 Closed cap pickup window channel kit	55.00	A-45987	Angled "T" rubber strip for open car door bottom 50"	5.65
A-45883 T	1928-31 Tudor door top cover plate, 1928-29 Coupe, taxi, and 1928-31 deluxe delivery, 1930-31 pickup.	57.00 ea.	A-45988	1928-31 Closed car bottom door seal. Fits at the bottom of the door between inner panel and door to make a seal. One roll will do car, truck or fordor.	6.25 roll
A-45963 A	Metal glass channel, R.H. fordor, Both doors are the same	10.50	A-46250 P	Inside door handle pins 1/8 x 5/8. Set of 4.	.75 set
A-45962	1928-31 Metal glass channel. Coupe and tudor front	9.50	B-47106	1930-36 Coupe, rear roll down window glass channel	9.50
			A-56787	1928-31 Tudor rear side window glass channel.	9.50
			A-45883 SS	Door top cover plate screws, stainless steel	1.50

Window Regulator and Glass Channel and Weather Stripping *(Continued)*

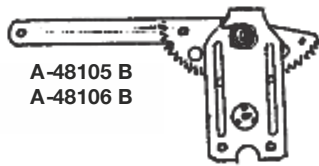

A-48105 B
A-48106 B



A-48105 RK5



A-48141



B-704220
B-773540



A-48301



A-48250 H



A-48250 V

NUMBER	NAME OF PART	PRICE	NUMBER	NAME OF PART	PRICE
A-48105 A	Window regulator, 3 mounting holes, right hand	36.95 ea.	A-48250 H	1928-31 Deluxe Fordor brackets for assist strap horizontal holes	5.50 ea.
A-48105 B	Window regulator, 4 mounting holes, right hand	38.95 ea.	A-48250 V	Late 1931 Deluxe Fordor brackets for assist strap vertical holes	5.50 ea.
A-48105 RK5	Window regulator repair kit, 5 tooth	27.00	A-48300-24 BR	24" Rear window shade - coupe, tudor, & Sedan - brown	26.00
A-48105 RK6	Window regulator repair kit, 6 tooth	16.95	A-48301	1928-31 Closed car window shade brackets	13.95 pr.
A-48106 A	1024-31 Window regulator, 3 mounting holes, left hand	36.95 ea.	A-48105 MB	1928-31 Window regulator mounting screws. Coupe, Tudor, and Pickup	1.50 set
A-48106 B	Window regulator, 4 mounting holes, left hand	38.95 ea.	A-56791 B	1931 Slant windshield rear door window & 1/4 window channel kit	84.00
A-48107 A	1930-31 Slant windshield, Victoria, 68C Cabriolet window regulator gear.	29.00	B-704220	1928-36 Rear glass rubber	3.75
A-48107 B	1930-31 Slant windshield, Victoria, 68C Cabriolet window regulator gear shaft.	42.00	B-773540	1928-41 Quarter window rubber. 1 set per car.	4.00 pr.
A-48107 C	1930-31 Slant windshield, Victoria, 68C Cabriolet gear cup.	45.00			
A-48141	Glass bumper, stop for side glass, closed cars	.75			



A-45987 A

Metal Retainer for Felt Window Channels

U shaped metal spot welded and riveted to door for felt channels to attach to. Includes rivet. Front is used on the hinge side of the door. Rear is used on the lock side of the door.

NUMBER	NAME OF PART	PRICE	NUMBER	NAME OF PART	PRICE
A-45980	1928-29 Right front/left lock side Coupes, Tudors and deluxe delivery	10.00 ea.	A-45996	1930-31 Right hinge side, Coupe & Sport Coupe	10.00 ea.
A-45981	1928-29 Left front/right lock side Coupes, Tudors and deluxe delivery	10.00 ea.	A-45997 A	1930-31 Left hinge side, Coupe & Sport Coupe	10.00 ea.
A-45986 A	1930-31 Right lock side, Coupe and Sport Coupe	10.00 ea.	A-55980	1930-31 Left/right hinge side, Tudor Sedan	10.00 ea.
A-45987 A	1930-31 Left lock side, Coupe and Sport Coupe	10.00 ea.	A-55981	1930-31 Right lock side, Tudor Sedan	10.00 ea.
			A-55982	1930-31 Left lock side, Tudor Sedan	10.00 ea.



A-48300 AG

Garnish Moulding (Fiberglass)

NUMBER	NAME OF PART	PRICE	NUMBER	NAME OF PART	PRICE
A-48300 AG	1928-29 Coupe rear quarter window. Fits either side.	90.00	A-48300 BRG	1930-31 Coupe passenger side rear quarter window.	90.00
A-48300 BLG	1930-31 Coupe driver side rear quarter window.	90.00			

Garnish Moulding

(Metal)

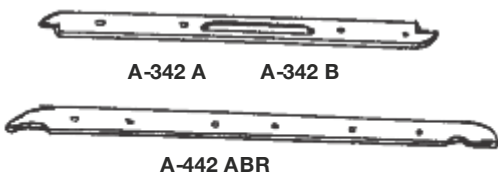

Slant windshield cars used this piece under regular mouldings at the windows

NUMBER	NAME OF PART	PRICE	NUMBER	NAME OF PART	PRICE
A-342 A	1928-29 Coupe & tudor steel garnish moulding	99.00 pr.	A-542 BFD	1931 Slant windshield front doors	85.00 ea.
A-342 B	1930-31 Coupe steel garnish moulding	99.00 pr.	A-542 BRD	1931 Slant windshield rear doors	85.00 ea.
A-342 MB	Garnish moulding mounting screws for coupe (set of 8), stainless steel	2.00 set	A-542 BQ	1931 Slant windshield quarter Window	75.00 ea.
A-442 B	1930-31 Tudor sedan and pickup	99.00 pr.	A-542 BVHR	1930-31 Victoria leather back right door header strip	95.00
A-442 ABR	1928-31 Tudor sedan rear side window garnish moulding	99.00 pr.	A-542 BVHL	1930-31 Victoria leather back left door header strip	95.00 ea.
A-842 A	1928-29 Closed cab pu garnish moulding	99.00 pr.	A-542 BVL	1930-31 Victoria left door	92.00 ea.
A-48300	1928-31 Coupe & Tudor rear window garnish moulding window frame	80.00	A-542 BVR	1930-31 Victoria right door	92.00 ea.
			A-542 BVHT	1930-31 Victoria steel back left door header strip	75.00
			A-542-BVHS	1930-31 Victoria steel back door header strip	75.00 ea.
			A-542 BVQ	1930-31 Victoria quarter window	79.00 ea.

Inside Door and Window Handles

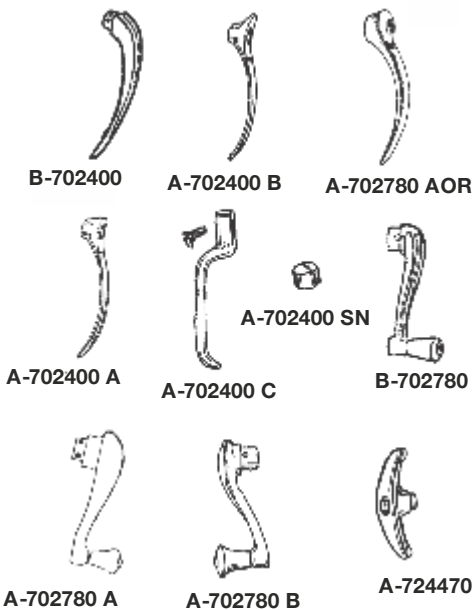

NUMBER	NAME OF PART	PRICE
B-702400	Inside handle for victoria A-400 and some fordors	9.75
A-702400 A	1928-31 Coupe and tudor inside door handle	8.75
A-702780 AOR	1928-31 Standard coupe and tudor inside door opener. Identical to original.	6.75 ea.
A-702400 B	1928-31 Fordor and cabriolet	8.75
A-702400 C	1928-31 Open Cars	8.75
A-702400 SN	1928-31 Sleeve nut and lock washer for inside door handle	1.25
B-702780	1930-31 Victoria A-400 and some fordors	12.00
A-702780 A	1928-31 Inside window handles	7.00
A-702780 B	1928-31 Fordor, scroll type	11.00
A-724470	1928-32 Quarter window regulator handle exact reproduction of original. Fits all fordor and town sedans with roll down quarter windows. Also rear window of 1931-34 Rumble seat coupe.	10.00 ea.

Inside Door and Window Handle Escutcheons

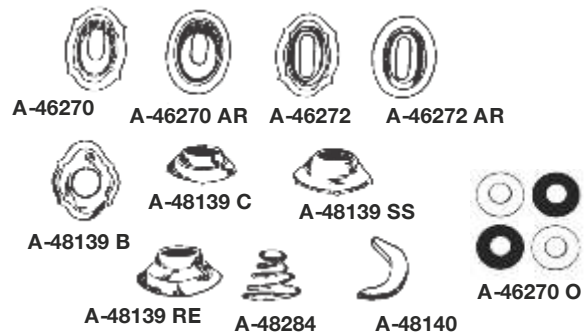

NUMBER	NAME OF PART	PRICE
A-46270	1928-31 Closed car door handle escutcheon, deluxe	4.00
A-46270 AR	1928-31 Standard door opener escutcheon	5.75
A-46270 O	1928-31 Inside door handle, escutcheon	3.00
A-46272	1928-31 Inside door lock escutcheon	3.00
A-46272 AR	1928-31 Standard door lock escutcheon, deluxe	6.00
A-48139 B	1930-31 Window handle escutcheon plate, chrome, deluxe	2.95
A-48139 C	1930-31 Small ringed escutcheon plate, used behind inside door handle and window crank on A-400's victoria, cabriolet and 1931 deluxe slant windshield sedan, duplicate of original. Polished stainless steel.	3.25
A-48139 RE	1924-48 Replacement type escutcheon plate for window riser. Chrome finish, spring loaded.	4.25
A-48139 A	1928-31 Escutcheon, large plain one used on most standard model closed cars and trucks. USA Duplicate of original.	3.25 ea.
A-48140	Door upholstery bezel	2.85 pr.
A-48284	Escutcheon spring	.65

Miscellaneous Door Parts (continued)

* Official Licensed Product
 Official Licensed Product
 Official Licensed Product

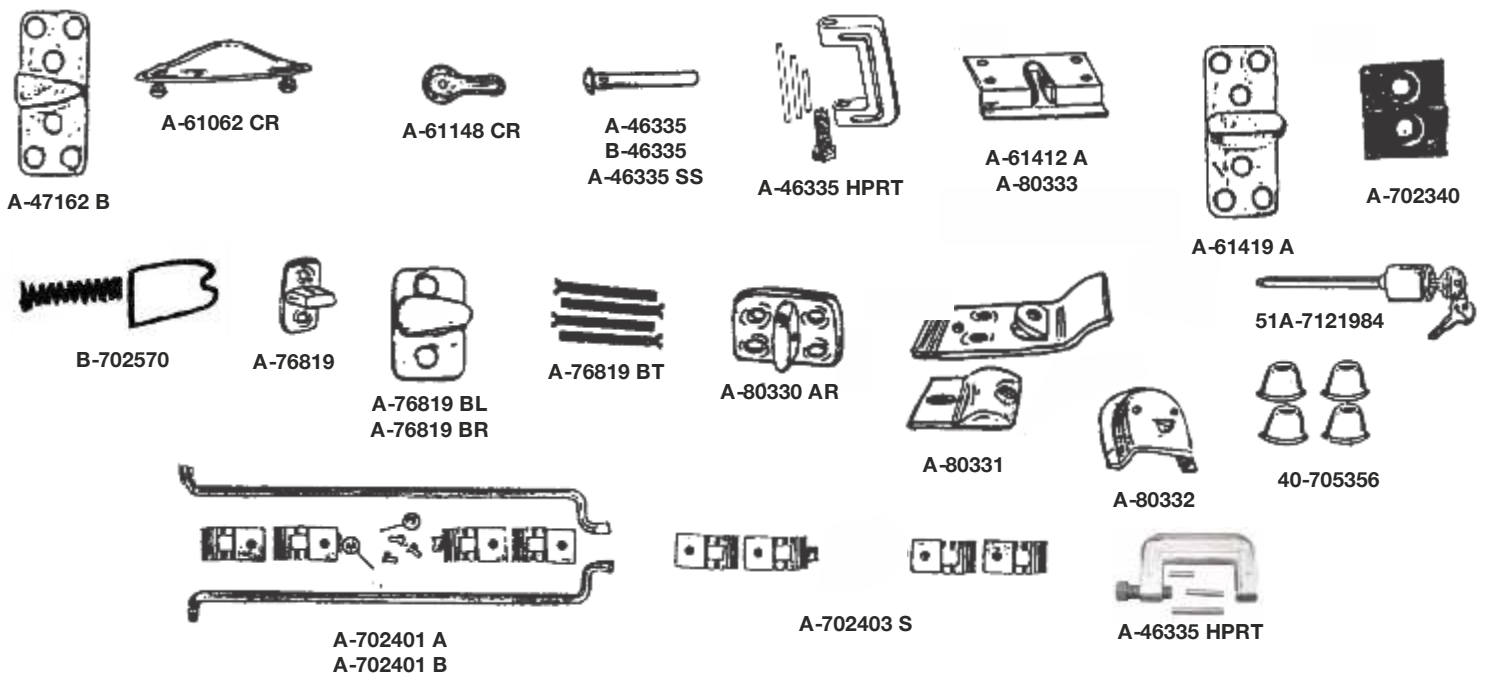

NUMBER	NAME OF PART	PRICE	NUMBER	NAME OF PART	PRICE
A-46335	1928-31 Closed car hinge pins, hardened with knurled shank except 1931 slant windshield, 1-13/16 x .223	.40 ea. or 6/1.75	A-702336	1931 Striker nut plate. Fits on back of door post. Screws for striker plate attach to this plate.	13.95
A-46335 OS	1928-31 Closed car door hinge pins, oversize 1-13/16 x .244	.40 ea. or 6/1.75	A-702340	Strike plate for 160-A, B, & C	7.25
A-46335 HPRT	Hinge Pin removal tool	35.00	B-702570	1931 Slant window dovetail wedge & spring	5.50
A-46335 SS	1928-31 Coupe tudor stainless steel hinge pins	2.50 ea.	A-76819	1928-31 Open car, coupe and tudor 2-hole dovetail	2.25
B-46335	1931-32 Hinge pins, fits all slant windshield A's 9/32" diameter	.90 ea.	A-76819 ABP	Dovetail backing plate	9.35
B-46335 S	1931-32 Stainless hinge pins for slant windshield cars	1.95	A-76819 BL	Slant windshield, male, dovetail for front drivers side door	13.25
A-47162 B	1930-31 Deluxe phaeton & panel delivery male dovetail	14.95	A-76819 BR	Slant windshield, male, dovetail for front passengers side door	13.25
A-48167	1929-30 Cabriolet quarter pillar upper windlace (68A & 68B)	90.00 pr.	A-76819 BT	Mounting screws for coupe & tudor dovetail package of 4	1.25
A-48168	1931 Cabriolet windlace retainer - 68C	75.00 pr.	A-80330 AR	1928-29 4-hole closed cab pickup male dovetail	3.00
A-61062 CR	Door pull handle on cabriolet and fordor	10.00	A-80331	1928-29 Closed cab pickup strike-plate, 2 pc.	10.50
A-61148 CR	1928-31 Lock knob, turn type	5.75	A-80332	1928-29 Closed cab pickup door bumper retainer	4.00
A-61412 A	1928-31 Complete dovetail assembly with rubber and metal clip installed. Fits all 4-door sedans except slant windshield models.	11.95	A-80333	Female dovetail assy. Complete with clip & rubber, Fits 1928-29 pickup	10.50 ea.
A-61412 MB	1928-31 Fordor female dovetail screws (4 pcs.)	.50 set	51A-7121984	1928-48 Door lock assembly, fits below handle	14.00
A-61412 C	1931 Victoria & A-400 female dovetail.	38.00	A-702401 A	1928-29 Coupe and tudor, 1930-31 tudor & pickup inside door latch remote rods	29.00 set
A-61419 A	6 Hole male dovetail, fits most all of the Fordor sedans and some Cabriolets	11.95 ea.	A-702401 B	1930-31 Coupe same as above	29.00 set
			A-702403 S	1928-31 door latch remote rod mounting plates for Coupe, tudor & pickup.	10.50 set

Door Check Straps

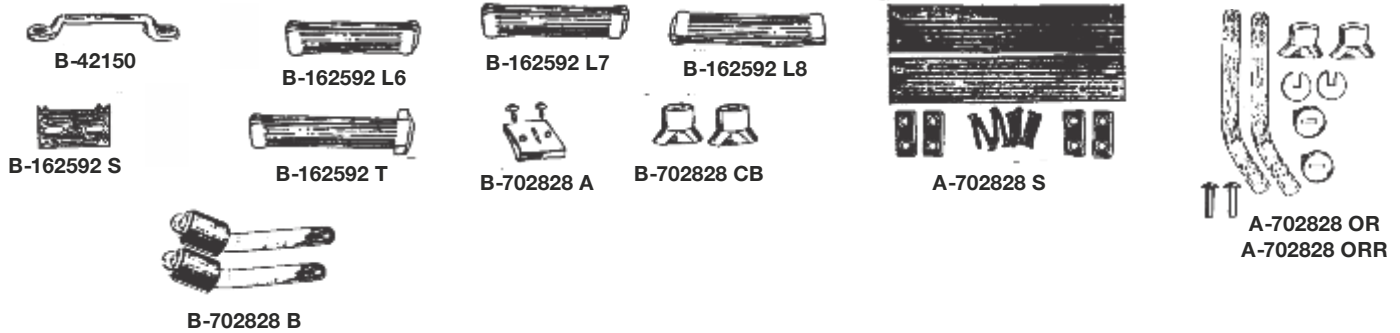

NUMBER	NAME OF PART	PRICE	NUMBER	NAME OF PART	PRICE
B-42150	1913-48 Footman Loop	1.15	A-702828 OR	1930-31 Original style door check arms for closed car front doors, correctly shaped with 3 slots for adjustment	15.00 set
B-162592 L6	1928-48 Loop type, 6 inch	2.75	A-702828 ORR	1930-31 Sedan rear door - same as above but has sharper bend	15.00 set
B-162592 L7	1928-48 Loop type, 7 inch	2.75	B-702828 CB	1928-34 Rubber bumper for closed car door check arm	1.75 pr.
B-162592 L8	1928-48 Loop type, 8 inch	2.75	A-702828 S	Leather check strap set	20.75
B-162592 S	1928-36 Adjustable bracket/saw tooth retainer plate, use with B-162592 T	3.50	A-702829	1930-31 Front door check arm brackets	5.00 pr.
B-162592 T	1928-36 Flat type	6.00	A-702829 4DR	1928-31 Rear door check arm brackets - straight windshield fordor	15.00 pr.
B-702828 A	1928-48 Door check arm, rubber pad with screws, replacement style	3.25 set			
B-702828 B	1928-37 Replacement type door check arm with rubber bumper	6.00			

Door Seal Kits

Not original but a good solution for door seals on early cars as well as deck lids and rumble seat. A USA made sponge rubber made to be compressed in door and trunk openings. Easy to install with pressure sensitive backing. Two sizes to choose from.

NUMBER	NAME OF PART	PRICE	HR-701980 L	HR-701980 S
HR-701980 L	5/8" Wide x 3/8" thick, 20 ft.	20.00		
HR-701980 S	3/8" Wide x 3/16" thick, 20 ft.	15.95		

Door Sill Plates

* Official Licensed Product
Official Licensed Product

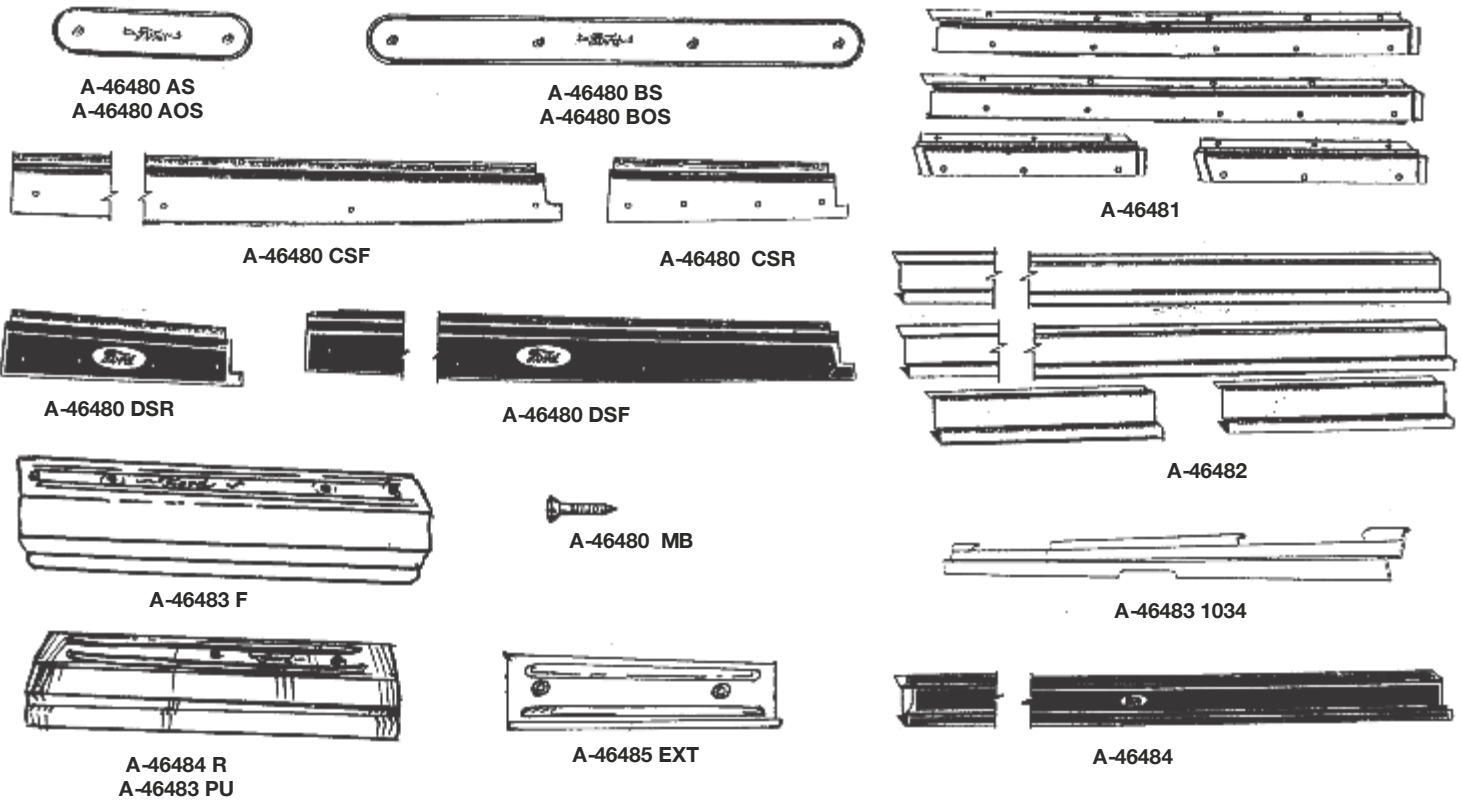

NUMBER	NAME OF PART	PRICE	NUMBER	NAME OF PART	PRICE
*A-46480 AOS	1928-31 Coupe sill plate zinc as original	17.00 pr.	A-46480 OMB	1928-31 Fordor sill plate screws 38 pcs for original plates	3.75 set
*A-46480 AS	1928-31 Coupe sill plates, 8" in length, aluminum	10.75 pr.	A-46480 RMB	1928-31 Fordor sill plate screws 38 pcs for reproduction plates	3.10 set
A-46480 ASS	1928-31 Coupe stainless steel sill plates, 8" in length.	Disc.	A-46481	1931 Slant windshield fordor sill plates, 4 pcs.	124.00 set
*A-46480 BOS	1928-31 Tudor sill plate zinc as original	31.00 pr.	A-46481 MB	1931 Slant windshield fordor sill plate screws (36 pc set)	3.00 set
*A-46480 BS	1928-31 Tudor sedan sill plates 19-5/8" in length, aluminum	19.00 pr.	A-46481 SWC	1931 Slant windshield cabriolet door sill plate	80.00
A-46480 BSS	1928-31 Tudor sedan stainless steel sill plates, 19 5/8" in length.	Disc.	A-46482	1930-31 Standard fordor murray, 4 pcs.	135.00 set
A-46480 CSF	1928-29 briggs fordor and cabriolets front plain	70.00 pr.	A-46482 DLX	1930-31 Deluxe fordor murray sill plates - Etched, 4 pcs	129.00 set
A-46480 CSR	1928-29 briggs fordor rear sill plates	50.00 pr.	*A-46483 F	1928-29 Open car front sill plates.	150.00 pr.
A-46480 DSF	1929-31 fordor and cabriolet front sill plates etched	75.00 pr.	A-46483 PU	1928-29 Roadster pu sill plates	150.00 pr.
A-46480 DSR	1929-31 fordor and cabriolet rear sill plates	55.00	A-46483 1034	Sill plate brackets roadster & roadster pickup (fits under & supports A-46483)	33.00
A-46480 MB	Coupe and tudor sill plate stainless steel screws (set of 8)	.80 set	*A-46484 R	1928-29 Open car rear sill plate, phaeton	150.00 pr.
			A-46485 Ext	1928-29 Open car sill plate extension rear (phaeton) left or right	45.00 pr.
			*A-46484	Victoria sill plates	130.00 pr.

Seat Adjustment Parts

* Official Licensed Product
Old World Iron Works

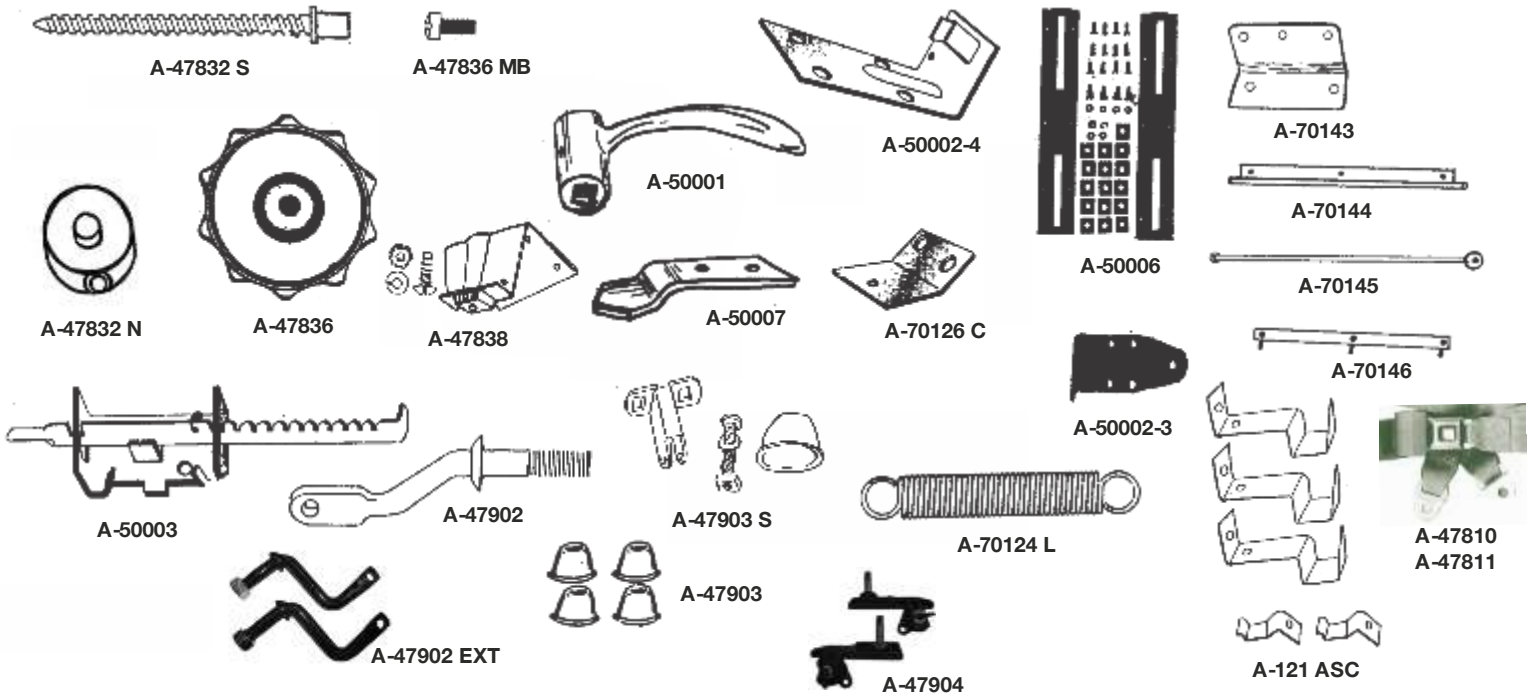

NUMBER	NAME OF PART	PRICE	NUMBER	NAME OF PART	PRICE
A-47832 N	1930-31 Seat adjustment nut. Caged on the seat assembly	13.50	A-50002-4	1930-33 Seat adjustment latch - 4 hole mounting bolt pattern	20.00
A-47832 S	1930-31 Seat adjustment threaded bolt	16.50	A-50003	1930-33 Seat adjusting mechanism	63.00
A-47835	1930-31 Seat adjuster knob washer	1.30	A-50004	1930-33 Sliding seat tracks - angle style - Tudor Deluxe Sedan, Victoria, Tudor Phaeton, A-400	95.00
A-47836	1930-31 Coupe & cabriolet and 1929-31 Fordor & town sedan seat adjustment handle	12.50 ea.	A-50005	1930-33 Sliding seat tracks - flat style Fordor Sedan, 4 stud	75.00
A-47836 MB	1930-31 Seat adjuster handle screw (fits A-47836)	.60 ea.	A-50006	1930-31 Coupe Seat Tracks	75.00 set
A-47837	1930-31 Seat adjuster bracket	25.00	A-50007	Seat spring hooks, Pickup backrest	4.00 ea.
A-47838	1930-31 Seat adjustment bracket with nut installed	58.00	A-70124 L	Seat adjustment mechanism spring (used with A-50003)	5.25
A-47902	1928-31 Tudor Front seat mounting bracket	16.95	A-121 ASC	1928-29 Roadster seat backrest spring clip set	32.00
A-47902 EXT	1928-31 Tudor front seat mounting bracket with 2" offset	39.50	A-70126 C	Spring clip bracket, used on late DLX 1931 Tudor and Victoria, mounts on wood seat frame and holds end of A-70124 L spring.	13.75
A-47903	1928-29 Tudor Sedan seat rest cups 3/4"	2.00	A-70143	1930-31 Victoria L-shaped seat mounting brace for seat hinge rod. 4 required.	25.50
A-47903 S	1928-31 Tudor front seat hardware set. 2 needed per car.	8.00	A-70144	1930-31 Victoria seat hinge channel. Attaches to wood seat for seat hinge rod to hinge in.	62.50
A-47903 T	1928-31 Tudor Sedan seat rest cups 1-1/4"	2.00	A-70145	1930-31 Victoria seat hinge rod with nut.	30.00
A-47904	1928-19 Tudor Sedan front seat adjustable bracket	140.00	A-70146	1930-31 Victoria seat hinge channel reinforcement.	27.00
A-47907	Fits on the bottom of the seat on some models to locate seat cushion.	14.00	A-70147	1930-31 Rear seat male catch- Victoria, A-400 & Deluxe Phaeton.	19.95
A-50001	1930-33 Seat adjustment handle-chrome 1930-31 Victoria	13.50			
A-50002-3	1930-33 Seat adjustment latch - 3 hole mounting bolt pattern	20.00			

Seat Belts

NUMBER	NAME OF PART	PRICE	NUMBER	NAME OF PART	PRICE
A-47810	Seat belt, push button type, black, 74"	17.50	A-47813	Seat belt, flip lever type, chrome, dark tan, 74"	26.95
A-47810 BT	Seat belt bolt kit - 1 kit per person	2.50	A-47814	Seat belt, flip lever type, chrome, light gray, 74"	26.95
A-47811	Seat belt, flip lever type, chrome, gray, 74"	26.95	A-47815	Seat belt, flip lever type, chrome, black, 74"	26.95
A-47812	Seat belt, flip lever type, chrome, light tan, 74"	26.95	A-47816	Seat belt retractor clips	24.95 pr.

A Pickup Truck

* Official Licensed Product
Official Aftermarket Accessories

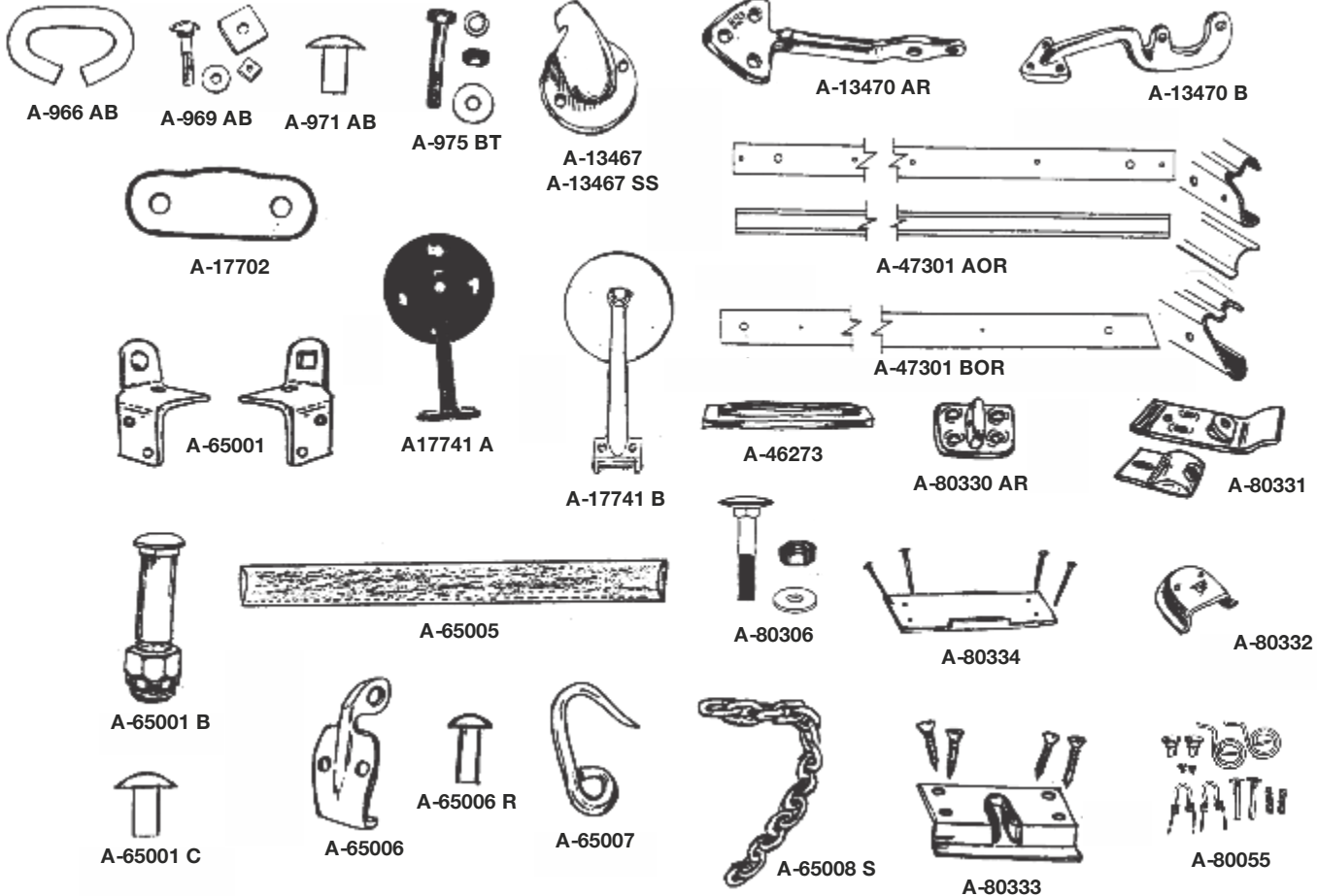

NUMBER	NAME OF PART	PRICE	NUMBER	NAME OF PART	PRICE
A-966 AB	Tail gate chain link. Attaches chain to tailgate.	3.25	A-65001 C	1926-31 Tail gate hinge bracket rivet (4)	1.00 set
A-969 AB	Pickup bed strip mounting bolt & washer set	12.95	A-65005	Chain cover	4.00 ea.
A-971 AB	PU bed rivets, complete set of rivets, set includes different lengths	10.00	A-65006	Pickup tail gate chain bracket	9.25 ea.
A-975 BT	1928-31 Pickup bed to frame bolt set	5.25 set	A-65006 R	Pickup tail gate chain bracket rivets (4)	1.00 set
A-13467	1928-34 Pickup tail light shield, black	6.25	A-65007	Pickup tail gate hook	6.00 ea.
A-13467 SS	1928-34 Pickup tail light shield, stainless steel	8.95	A-65008 S	Pickup tail gate chain	4.25 ea.
A-13470 AR	1928-29 Pickup tail lamp bracket, cast iron	17.00	A-80301 L	1928-29 Closed cab left hand upper door window frame	60.00 ea.
A-13470 B	1930-31 Pickup tail lamp bracket	9.00	A-80301 R	1928-29 Closed cab right hand upper door window frame	60.00 ea.
A-17702	Moulded rubber rear view mirror mounting pad 1928-29 pickup	1.75	A-80303	1928-29 Closed cab pickup plugs the hole above the outside door handle.	6.00
A-17741 A	Outside mirror and bracket. Will fit 1928-29 closed cab pickup, 1928-30 panel delivery, 1928-30 AA panel delivery, 1929-31 deluxe delivery, 1928-31 station wagon	24.95	A-80304	1930-31 Closed cab pickup dispatch pocket	19.50
A-17741 B	Outside mirror and bracket. Will fit 1930-31 closed cab pickup. Fits on door hinge pin	22.50	A-80306	1930-31 Closed cab pickup belt rail bolts, nuts, & washers (15 pcs.)	2.50 set
A-46273	Pickup moulded rubber anti-rattle for inside door opener lever, same as T-8320 BX	3.50 pr.	A-80330 AR	Four hole dovetail 28-29 closed cab pickups	3.00 ea.
A-47301 AOR	1928-29 Rain gutter. Closed cab pickup	32.00 pr.	A-80331	1928-29 Closed cab pickup striker, 2 pc.	10.50 ea.
A-47301 BOR	1930-31 Rain gutter. Closed cab pickup	32.00 pr.	A-80332	1928-29 Closed cab pickup stamped steel part that holds door bumper	4.00 ea.
A-65001	1926-31 Tail gate hinge brackets, 2 pc. set	10.00 set	A-80333	1928-29 Pickup female dovetail	10.50 ea.
A-65001 B	1926-31 Tail gate hinge bracket bolts & nuts	5.25 ea.	A-80334	1928-29 Closed cab pickup striker shield mounts to door jam	4.95 ea.
			A-80055	1926-29 Pickup, coupe & tudor door latch repair kit. Complete with all springs & rivets to rebuild both latches.	14.95 set
			A-80080	1928-31 Roadster pickup truck belt rail to top fasteners	15.95 ea.

Outside Door Handles



A-702350 AL



A-702350 BL



A-702350 C
A-702350 D



A-702350 DL



A-702351 C

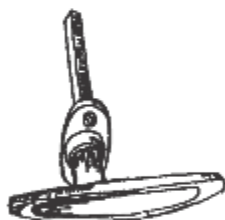

A-702350 O
A-702350 OSB
A-702350 OSA

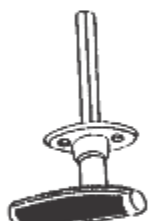

A-702350 P



A-702351 A



A-702351 B

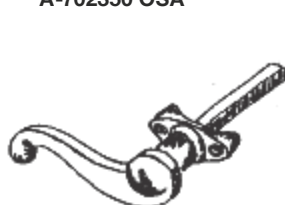

A-702351 D

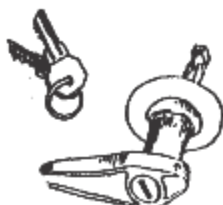

A-702352 A



A-702352 B



(4)
A-702350/51



(4)
A-702350/51 BT



51A-7121984

NUMBER	NAME OF PART	PRICE	NUMBER	NAME OF PART	PRICE
A-46250 P	Door handle pins 1/8" x 5/8", set of 4	.75 set	A-702351 A	1928-29 Coupe and Tudor - non-locking	32.50
A-702350 AL	1928-29 Coupe and Tudor - locking	34.00	A-702351 B	1930-31 Coupe, Tudor and Pickup non-locking	32.50
A-702350 BL	1930-31 Coupe and Tudor - locking	34.00	A-702351 C	1928-29 Fordor and Cabriolet - left hand	32.00
A-702350 C	1928-29 Fordor and Cabriolet - right hand	32.00	A-702351 D	1930-31 Fordor and Cabriolet - left hand	32.00
A-702350 D	1930-31 Fordor and Cabriolet - right hand	32.00	A-702352 A	1928-31 Coupe and Roadster rumble handle	39.00
A-702350 DL	1930-31 Victoria and 1931 Cabriolet, Fordor and Town Sedan, locking	43.50	A-702352 B	1929-31 Cabriolet Scroll Rumble handle. Will also fit Coupe & Roadster	37.50
A-702350 O	1928-31 Open car, Roadster and Phaeton chrome	28.00	A-702350/51	Exterior door handle screws, for wood frame doors (4)	1.25 set
A-702350 P	1928-29 Closed cab pickup outside handle	29.95	A-702350/51 BT	Exterior door handle screws, longer for reproduction handles (4)	1.00 set
A-702350 OSS	1928-31 Stainless steel open car outside door handle	25.00	51A-7121984	Door lock assembly	14.00

Outside Door Handle Pads

NUMBER	NAME OF PART	PRICE
A-702356	1928-31 Open car handle pad	.80 pr.
A-702356 AM	1928-31 Moulded rubber open car handle pad	2.25 pr.
A-702356 BM	1928-31 Moulded rubber closed car outside door handle pads - Except 28-29 fordors	2.25 pr.
A-702356 B	1928-29 Coupe and Tudor	.90 pr.
A-702356 C	1928-29 Fordor	.80 pr.
A-702356 D	1930-31 Closed car	.90 pr.
A-702356 E	Rumble handle pad	.50 ea.
A-702356 EM	1928-31 Moulded rubber rumble handle pad	2.25 ea.



A-702356



A-702356 AM



A-702356 B



A-702356 C



A-702356 D



A-702356 E



A-702356 EM

Wood Parts



Top Wood

NUMBER	NAME OF PART	PRICE
AWD-1000	Wood, 1931 Convertible Sedan Top Wood (400-A)	630.00
AWD-1025	Wood, 1928-29 Tudor Top Wood Kit (55-A)	435.00
AWD-1027	Wood, 1930-31 Tudor Top Wood Kit (55-B)	465.00
AWD-1027-6	Wood, 1928-31 Tudor Top Wood Corners (Strainers-Pair)	78.00
AWD-1028	Wood, 1928-29 Std. Coupe Top Wood (45-A)	350.00
AWD-1029	Wood, 1928-29 Special Coupe Top Wood (49-A)	358.00
AWD-1030	Wood, 1929 Business Coupe Top Wood (54-A)	450.00
AWD-1031	Wood, 1930-31 Std. Coupe Top Wood (45-B)	351.00
AWD-1033	Wood, 1928-29 Closed Cab Pickup & AA Truck Top Wood (82-A)	351.00
AWD-1035	Wood, 1930-31, Closed Cab Pickup & AA Top Wood (82-B)	301.00
AWD-1036	Wood, Late 1931 Closed Cab Pickup Top Wood (All steel Top)	249.00
AWD-1060-L	Wood, 1930-31 Victoria Leather-Back Top Wood (190-A)	1,065.00
AWD-1060-S	Wood, 1930-31 Victoria Steelback Top Wood (190-A)	1,010.00
AWD-1065	Wood, 1930-31 Sedan Delivery top wood.	794.00
AWD-1085 TW	Wood, 1928-29 Sport Coupe Top Wood (50-A)	470.00
AWD-1086 TW	Wood, 1930-31 Sport Coupe Top Wood (50-B)	470.00
AWD-FA	Wood, 1929 Briggs Fordor Top Wood (155-B, 165-B, 170-A)	1,025.00
AWD-GA	Wood, 1929 Briggs Fordor Steelback Top Wood (60-C)	1,025.00
AWD-HA	Wood, 1928-29 Briggs Fordor Leatherback Top Wood (60-A&B)	1,060.00
AWD-IA	Wood, 1930-31 Murray Fordor Top (155-C)	1,025.00
AWD-JA	Wood, 1930-31 Briggs Fordor Town Sedan Top Wood	1,025.00
AWD-KA	Wood, 1931 Cabriolet Slant Windshield Top Wood (68-C)	500.00
AWD-LA	Wood, 1929-31 Cabriolet, Straight Windshield Top Wood (68-A&B)	500.00
AWD-MA	Wood, 1931 Fordor Slant Windshield Top Wood (160-A, B, C)	505.00
AWD-NA	Wood, 1929 Murray Fordor Top (155-A)	1,025.00

NUMBER	NAME OF PART	PRICE
AWD-IA-1	Wood, 1930-31 Murray Fordor Header (155-C, 165-C)	148.00
AWD-JA-1	Wood, 1930-31 Briggs Fordor Header (155-D, 165-D, 170-B)	126.00
AWD-KA-1	Wood, 1931 Cabriolet Slant Windshield Header (68-C)	115.00
AWD-LA-1	Wood, 1930-31 Cabriolet Straight Windshield Header (68-B)	115.00
AWD-NA-1	Wood, 1929 Murray Town Sedan Header (155-A, 165-A)	132.00
AWD-RD-1	Wood, 1930-31 Deluxe Roadster Header (40-B)	65.00

Body Wood

NUMBER	NAME OF PART	PRICE
AWD-1001	Wood, 1931 Convertible Sedan Body Wood (400-A)	1,010.00
AWD-1260 L	Wood, 1930-31 Victoria Leatherback Body Wood (190-A)	1,380.00
AWD-1260 S	Wood, 1930-31 Victoria Steelback Body Wood (190-A)	1,185.00
AWD-1265	Wood, 1930-31 Sedan Delivery body wood.	840.00
AWD-1275	Wood, 1928-29 Roadster Pickup Body Wood (76-A)	155.00
AWD-1276	Wood, 1928-29 Roadster Body Wood (40-A)	170.00
AWD-1277	Wood, 1928-29 Phaeton Body Wood (35-A)	320.00
AWD-1278	Wood, 1930-31 Roadster Body Wood (40-B)	170.00
AWD-1280	Wood, 1928-29 Tudor Sedan Body Wood (55-A)	308.00
AWD-1281	Wood, 1930-31 Tudor Sedan Body Wood (55-B)	310.00
AWD-1282	Wood, 1928-29 Pickup & AA Truck Body Wood (82-A)	197.00
AWD-1283	Wood, 1930-31 Pickup & AA Truck Body Wood (82-B)	170.00
AWD-1285	Wood, 1928-29 Sport Coupe Body Wood (50-A)	330.00
AWD-1286	Wood, 1928-29 Special Coupe Body Wood (49-A)	665.00
AWD-1287	Wood, 1928-29 Standard Coupe Body Wood (45-A)	355.00
AWD-1288	Wood, 1930-31 Standard Coupe Body Wood (45-B)	360.00
AWD-1290	Wood, 1930-31 Standard Fordor Phaeton body wood.	320.00
AWD-1292	Wood, 1929-31 Cabriolet Straight Windshield Body Wood (68-A&B)	365.00
AWD-1295	Wood, 1930-31 Sport Coupe Body Wood (50-B)	338.00
AWD-1296	Wood, 1931 Slant Windshield Fordor Body Wood (160-A, B&C)	365.00
AWD-1298	Wood, 1930-31 Roadster Pickup Body Wood (76-B)	73.00
AWD-FB	Wood, 1929 Briggs Fordor Body Wood (155-B, 165-B, 170-A)	1,670.00
AWD-HB	Wood, 1928-29 Briggs Fordor Leatherback Body Wood (60-A&B)	2,160.00
AWD-IB	Wood, 1929-31 Murray Fordor Body Wood (155-A, 165-A, 155-C, 165-C)	1,710.00
AWD-JB	Wood, 1930-31 Briggs Fordor Body Wood (155-D, 165-D, 170-B)	1,670.00
AWD-KB	Wood, 1931 Cabriolet Slant Windshield Body Wood (68-C)	375.00
A-800500	1930-31 Std. and Deluxe Coupe body wood bolt set - 212 pcs	23.00

Headers

NUMBER	NAME OF PART	PRICE
AWD-1000-1	Wood, 1931 Conv. Sedan Header (400-A)	120.00
AWD-1060-1	1930-31 Victoria & slant windshield Fordor header	116.00
AWD-1075	Wood, 1928-29 Coupe, Tudor, Deluxe Delivery Header	88.00
AWD-1077	Wood, 1930-31 Tudor, Closed Cab Pickup, DLX., DEL., Steel Top PU Header	115.00
AWD-1079	Wood, 1930-31 Coupe (45-B) Sport Coupe (50-B) Header	115.00
AWD-1081	Wood, 1928-29 Pickup & AA Header (82-A)	90.00
AWD-FA-1	Wood, 1929 Briggs Fordor Header (155-B, 165-B, 170-A)	130.00
AWD-GA-1	Wood, 1929 Briggs Fordor Steelback Header (60-C)	130.00
AWD-HA-1	Wood, 1928-29 Briggs Fordor Leatherback Header (60-A&B)	168.00

Seat Wood

NUMBER	NAME OF PART	PRICE
AWD-1408	Wood, 1928-31 Tudor Front Cushion Seat Frame (55-A) 2 required	52.00 ea.
AWD-1508	Wood, 1928-29 Coupe (45A) & Cabriolet (68 A&B) Fixed Seat Front Cushion Frame	103.00
AWD-1509	1928-29 Coupe (45A) & Cabriolet (68 A&B) Fixed Seat Back. Frame	103.00
AWD-1510	Wood, 1930-31 Coupe (45 B) & Cabriolet (68 B) Adj. Seat Carriage Bottom	106.00
AWD-1510 B	Wood, 1930-31 Coupe & Cabriolet Seat Spring Frame (ADJ Seat)	103.00
AWD-1511	Wood, 1930-31 Coupe (45B) & Cabriolet (68 B) Backrest Seat	106.00
AWD-1512	Wood, 1928-31 Tudor Rear Cushion Seat Frame Wood (55-A&B)	106.00
AWD-1513	Wood, 1928-31 Tudor Rear Backrest Seat Frame Wood (55-A&B)	106.00
AWD-1516 L	Wood, 1930-31 Vic. (190A) & Conv. Sed (400A) Left Frt. Seat Bottom Adj.	60.00
AWD-1516 R	Wood, 1930-31 Vic. (190A) & Conv. Sed (400A) R. Front Seat Bottom Adj.	70.00
AWD-1517	Wood, 1930-31 Vic. (190A) & 31 Convertible Sedan (400A) Rear Cushion Frame	125.00
AWD-1518	Wood, 1930-31 Vic. (190A) & 31 Convertible Sedan (400A) Rear Backrest. Frame	110.00
AWD-1520	Wood, 1928-29 Pickup & AA (82A) Seat Back Frame (4 PC)	44.00
AWD-1521	Wood, 1930-31 Pickup & AA (82B) Seat Back Frame (4 PC)	60.00
AWD-1522	Wood, 1928-29 Roadster Pickup (76A) Seat Back Frame (4 PC)	44.00
AWD-1523	Wood, 1928-29 Roadster (40A) Seat Back Frame (6 PC)	50.00
AWD-1525	Wood, 1930-31 Roadster (40B) Seat Back Frame (5 PC)	60.00

Chassis Wood

NUMBER	NAME OF PART	PRICE
AWD-500	Wood, 1930-31 Victoria chassis wood steel or leatherback (specify FS or ADJ)	875.00
AWD-1002	Wood, 1931 Convertible Sedan Chassis Wood (400-A)	828.00
AWD-1350	Wood, 1929-31 Cabriolet Chassis Wood (Specify Early 68-A or late 68-B fixed seat)	826.00
AWD-1360	1929-31 Cabriolet chassis wood (68-B adjustable seat)	826.00
AWD-1380	Wood, 1929 Murray Fordor Town Sedan Chassis Wood (155 & 165-A)	826.00
AWD-1393	Wood, 1931 Cabriolet Slant Windshield Chassis Wood (68-C)	826.00
AWD-FC	Wood, 1929 Briggs Fordor Town Sedan Chassis Wood	826.00
AWD-HC	Wood, 1928-29 Briggs Fordor Leatherback Chassis Wood (60 A&B)	826.00
AWD-JC	Wood, 1930-31 Briggs Fordor Town Sedan Chassis Wood (155-D)	826.00

Belt & Tack Rail Wood

NUMBER	NAME OF PART	PRICE
AWD-1001-2	Wood, 1931 Convertible Sedan Belt & Tack Rails - 3 PC (400-A)	275.00
AWD-1260-L-2	Wood, 1930-31 Victoria Leather-B Belt & Tack Rail-5 PC (190-A)	190.00
AWD-1260-S-2	Wood, 1930-31 Victoria Steelback Belt & Tack Rail-5 PC (190-A)	190.00
AWD-1276-2	Wood, 1928-29 Roadster Belt & Tack Rail-3 PC (40-A)	65.00
AWD-1277-2F	Wood, 1928-29 Phaeton Front Seat Belt & Tack Rail-3 PC (35-A)	63.00
AWD-1277-2R	Wood, 1928-29 Phaeton Rear Seat Belt & Tack Rail-3 PC (35-A)	63.00
AWD-1278-2	Wood, 1930-31 Roadster Belt & Tack Rail-3 PC (40-B)	63.00
AWD-1285-2	Wood, 1928-29 Sport Coupe Belt & Tack Rail-5 PC (50-A)	180.00
AWD-1286-2	Wood, 1928-29 Special Coupe Belt & Tack Rail-5 PC (49-A)	180.00
AWD-1288-RD	Wood, 1930-31 Coupe Roll Down Rear Window Wood	126.00
AWD-1292-2	Wood, 1929-31 Cabriolet Belt & Tack Rail-3 PC (68 A&B)	177.00
AWD-1295-2	Wood, 1930-31 Sport Coupe Belt & Tack Rail-5 PC (50-B)	180.00
AWD-KC-2	Wood, 1931 Cabriolet Slant W/S Belt & Tack Rail - 3 PC (68-C)	177.00

Door Wood

NUMBER	NAME OF PART	PRICE
AWD-1292-4	Wood, 1929-31 Cabriolet Door Wood with Metal Window Riser Mounting	390.00
AWD-1292-4A	Wood, 1929-30 Cabriolet Door with Wood Window Riser Mounting Board	710.00
AWD-HB-4	Wood, 1928-29 Briggs Fordor Leatherback Door Wood (60 A&B)	1,650.00
AWD-IB-4	Wood, 1929-31 Fordor Murray Door Wood (155, 165-A, 155, 165-C)	1,280.00
AWD-IC	Wood, 1930-31 Fordor Murray Door Wood	826.00
AWD-JB-4	Wood, 1929-31 Briggs Fordor Door Wood	1,280.00

Miscellaneous Wood

NUMBER	NAME OF PART	PRICE
AWD-970 ABL	Wood, Late 1931 Wide Bed Pickup Bed Sills	210.00
AWD-1225	Wood, 1928-31 Pickup Narrow Bed (Oak)	250.00
AWD-1235	Wood, 1928-31 Pickup Bed Side Boards (Oak)	145.00
AWD-DLC	Wood, 1928-31 Coupe & Tudor & 1930-31 Pickup Door Latch Covers	22.00

Call for price on wood needs that are not listed.

Top Irons

* Official Licensed Product
 Official Licensed Product

Open Car Top Irons. Set of top irons with the wood. Complete. Ready to install. Includes hold down clamps, thumb screws, prop nuts and rivets.

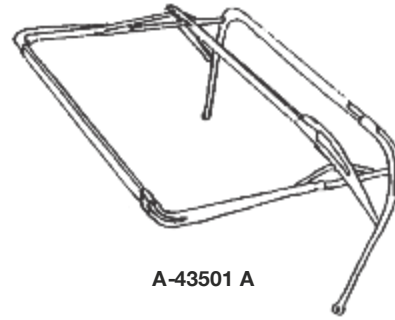

A-43501 A

STANDARD ROADSTER

A-43501 A	1928-29 Standard Roadster	705.00
A-43501 B	1930-31 Standard Roadster	705.00
A-43501 C	1931 Deluxe Roadster top irons, no bows	570.00
A-43501 D	1928-29 Roadster Pickup	625.00
A-43501 E	1930-31 Roadster Pickup	625.00

STANDARD PHAETON

A-43501 F	1928-29 Standard Phaeton	925.00
A-43501 G	1930-31 Standard Phaeton	925.00

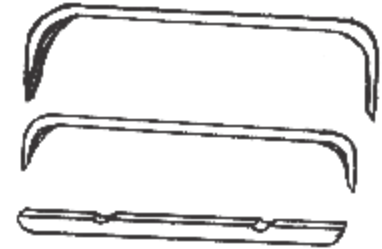

A-42057 B

STRAIGHT WOOD CROSS BOWS ONLY

A-42056 A	1928-29 Roadster	95.00 set
A-42056 B	1928-29 Phaeton	116.00 set
A-42056 C	1930-31 Roadster	95.00 set
A-42056 D	1930-31 Phaeton	116.00 set
AWD-42056 RP	Top bow repair strips, 48 x 1 1/2 x 1/4	3.00 ea.
A-42057 B	1931 Deluxe Roadster Top Bows, Steam Bent	369.95 set
A-42057 BMB	Top hardware needed to attach wood bows to 1931 Deluxe top irons.	15.00 set

CURTAIN RODS

A-41970 AR	1928-29 Roadster Top Irons	40.50 pr.
A-41970 A	1928-29 Touring Rear & Pickup	40.00 pr.
A-41970 B	1930-31 Standard Roadster	40.00 pr.
A-41970 C	1930-31 Deluxe Roadster	40.00 pr.

Top Wood Bolt Sets

NUMBER	NAME OF PART	PRICE
A-800400	1928-29 Tudor sedan top wood header, header only mounting kit - 10 pcs	5.25
A-800401	1928-29 Closed cab pickup top wood mounting kit - 72 pcs	13.00
A-800402	1928-29 Tudor sedan top wood mounting kit - 411 pcs	28.00
A-800501	1930-31 Tudor sedan top wood mounting kit - 188 pcs.	25.50
A-800502	1930-31 Standard & Deluxe Coupe top wood mounting kit - 226 pcs.	25.50
A-800503	1930-31 Closed cab pickup top wood mounting kit - 255 pcs	24.00

Seat Springs



We believe these are the best springs on the market and are duplicates of the originals. They are painted black and ready to install in your car. Please allow two weeks for delivery.



1928-29 Roadster

SP-100	Front cushion spring	190.00
SP-101	Front backrest spring	156.00
SP-102	Rumble cushion spring	149.00
SP-103	Rumble backrest spring	163.00

1930-31 Roadster

SP-104	Front cushion spring	178.00
SP-105	Front backrest spring	134.00
SP-106	Rumble cushion spring	149.00
SP-107	Rumble backrest spring	163.00

1928-29 Coupe

SP-301	Front cushion spring	180.00
SP-302	Front backrest spring	115.00
SP-303	Rumble cushion spring	149.00
SP-304	Rumble backrest spring	163.00

1930-31 Coupe

SP-305	Front cushion spring	187.00
SP-306	Front backrest spring	123.00
SP-306 L	Late 31 front back rest	131.00
SP-307	Rumble cushion spring	149.00
SP-308	Rumble backrest spring	163.50

1928-31 Tudor Sedan

SP-400 D	Front cushion spring, driver's side	95.00
SP-400 P	Front cushion spring, passenger's side	95.00
SP-401 D	Front backrest spring, driver's side	65.00
SP-401 P	Front backrest spring, passenger's side	65.00
SP-402	Rear cushion spring	192.00
SP-403	Rear backrest spring	155.00
SP-403A	Rear backrest spring, early 1928	219.00

1928-29 Briggs Leather & Steel Back (2-window)

SP-500	Front cushion spring	158.00
SP-501	Front backrest spring	157.00
SP-502	Rear cushion spring	207.00
SP-503	Rear backrest	125.75

1929 Standard Fordor & 3-window (Briggs & Murray)

SP-508	Front cushion spring	158.00
SP-509	Front backrest spring	157.00
SP-510	Rear cushion spring	220.00
SP-511	Rear backrest	278.00

1930-31 Standard Fordor (Briggs & Murray)

SP-516	Front cushion spring	193.00
SP-517	Front backrest spring	124.00
SP-518	Rear cushion spring	217.00
SP-519 A	Rear backrest spring	155.50

1929 - Early 31 Deluxe Town Sedan (Briggs & Murray)

SP-516	Front cushion spring	193.00
SP-517	Front backrest spring	124.00
SP-518	Rear cushion spring	217.00
SP-519	Rear backrest spring	161.00

Seat Springs *(continued)*



1931 Slant Windshield Fordor

SP-520	Front cushion spring	162.00
SP-521	Front backrest spring	160.00
SP-522	Rear cushion spring	189.00
SP-523	Rear backrest spring	171.00

1928-29 Cabriolet

SP-600	Front cushion spring	180.00
SP-601	Front backrest spring	115.00
SP-602	Rumble cushion spring	149.00
SP-603	Rumble backrest spring	163.00

1930-31 Cabriolet

SP-604	Front cushion spring	187.00
SP-605	Front backrest spring, 68-B	123.00
SP-605 L	Front backrest spring, 68	131.00
SP-606	Rumble cushion spring	149.00
SP-607	Rumble backrest spring	163.00

1928-29 Phaeton (with pleated cushion)

SP-701	Front cushion spring	190.00
SP-702	Front backrest spring	118.75
SP-703	Rear cushion spring	230.00
SP-704	Rear backrest spring	118.75

1930-31 Standard Fordor Phaeton

SP-705	Front cushion spring	178.00
SP-706	Front backrest spring	140.00
SP-707	Rear cushion spring	153.00
SP-708	Rear backrest spring	140.00

1930-31 Deluxe Tudor Phaeton

SP-709 D	Front cushion, driver's side	153.00
SP-709 P	Front cushion, passenger's side	153.00
SP-710 D	Front backrest, driver's side	63.50
SP-710 P	Front backrest, passenger's side	63.50
SP-711	Rear cushion, rumble type base	415.00
SP-712	Rear backrest	114.75

1928-29 Truck (Open and Closed)

SP-800	Cushion spring	166.00
SP-801	Backrest spring	144.00

1930-31 Truck (Open and Closed)

SP-802	Cushion spring	166.00
SP-803	Backrest spring	117.75

1931 Wide Bed Truck

SP-804	Cushion spring	184.00
SP-805	Backrest spring	116.00

1930-31 Victoria (Early style, Jan. 1930-June 1931)

SP-930	Front cushion spring, driver's side	73.50
SP-932	Front cushion spring, passenger's side	72.75
SP-931	Front backrest spring, driver's side	75.00
SP-933	Front backrest spring	75.00
SP-938	Rear cushion spring	260.00
SP-939	Rear backseat spring	203.00

1931 Victoria (Late, after June 1931)

SP-934	Front cushion spring, driver's side	140.00
SP-936	Front cushion spring, passenger's side	122.00
SP-935	Front backrest spring, driver's side	75.00
SP-937	Front backrest spring, passenger's side	75.00
SP-938	Rear cushion spring	260.00
SP-939	Rear Backrest spring	203.00

NOTE: DUE TO RECENT RECLASSIFICATION UPS WILL CHARGE 70 POUND RATE ON SOME SPRINGS.

Noise Makers

* Official Licensed Product
World's Best Performance



A-13802 BH

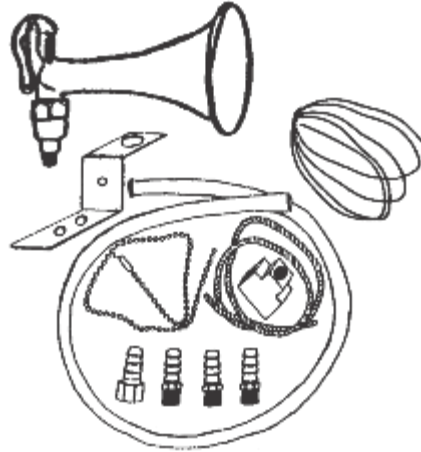

10 W



12



14

NUMBER	NAME OF PART	PRICE	NUMBER	NAME OF PART	PRICE
10M	Wolf whistle motor - screw in type	17.00	A-18752	Explosion, whistle, extremely loud shrill whistle, fits under spark plug and works off engine compression, adapter and pull wire included. For Model A only	65.00
10W	Wolf whistle, made over seas, all metal, complete with fittings. Works off intake vacuum. Guaranteed to enrage young feminists and make older ladies smile. (Model T intake must be drilled and tapped with 1/8" pipe tap)	45.00	A-18753	Model A Explosion whistle adapter fits under spark plug	14.75
12	Aermore exhaust whistle 15" long brass whistle, very noisy	225.00	A-18765	1928-31 Model A cut out also serves as Aermore whistle adapter	85.00
15	Cable kit. Braided 6 ft. cable with clamps. Used to operate Aermore.	7.50	A-18770	1928-29 Exhaust whistle similar to Aermore whistle (clamps to end of tail pipe)	135.00
A-13802 BH	Electric Bull Horn painted red. 12 volt.	49.95	T-4037 CO	1909-27 Model T exhaust pipe cut out & Aermore whistle adapter	80.00
A-13802 EC12	Economy Import AH-000-GA horn, 12 volt	24.95	T-6300 A	1909-27 Accessory foot control. Makes Model T driving easier and is a must for cars with Ruckstell rear ends of auxiliary transmissions. Allows you to cruise w/hand throttle and accelerate w/foot.	89.95
*A-13802 RG	A new original Sparton horn identical in every way to the original Horn. Complete with plate and mounting bracket. High quality USA mfr.	273.00	T-6300 B	1926-27 Accessory foot control (see above)	89.95
*A-13802 RG12	Same as above except 12V	265.00			

Grease Fittings & Tool Pouch

A-8501 GF	Brass grease fitting (for water pump) original	2.70 ea.
B-17005	Model A tool pouch	8.00
350326	Grease fitting drive-in-type - 16 ea.	7.50 set
350326/27/29 RE	Modern day grease fitting set. Replaces old drive in fittings on chassis.	14.00 set
353027	Threaded grease fitting, Need 10	.55 ea.
353029	25 degree fitting for front end, Need 2	.95 ea.
353030 T	Grease fitting driver - Original fittings only	3.25 ea.
353031	Shock link grease fitting	1.20 ea.
358010 A	1928-31 Threaded grease fitting adaptors, 4 ea. per package. Adapts threaded spring shackles to press in fittings	1.40 pkg.
X-353000 S	Grease gun adapter. Screws on after removal of conventional grease gun end	3.95 ea.
350326 M	Modern drive-in grease fitting	.30 ea.
353027 M	Modern threaded grease fitting	.45 ea.
353029 M	Modern 25-degree threaded grease fitting	1.75 ea.
353030 M	Modern grease fitting driver	2.25 ea.
353031 M	Modern threaded angled shock link grease fitting	1.00 ea.



A-8501 GF



B-17005



358010 A



353027



350326



350326/27/29 RE



353029



X-353000 S



353031



353030 T

Rivets

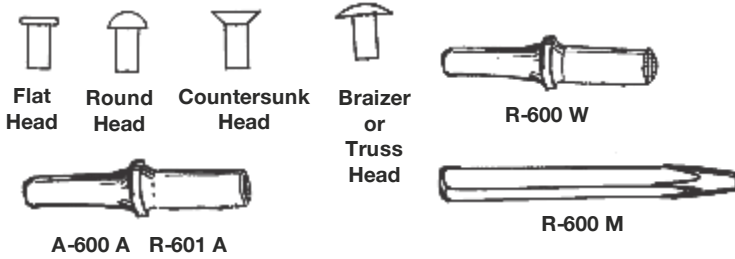

Interior Trim Screw Sets

These kits include all screws for the complete Model A interior. Includes instrument Panel, dash rail, window frame, doorstep and dovetail screws. Rear window frame screws are supplied on convertibles. We believe these screw sets to be the best quality available.

NUMBER	NAME OF PART	PRICE
R-500	Floor pans (3/16 diameter x 1/4" long truss head)	.95 (Pkg. of 5)
R-501	Floor sills 28-29 cowl (3/16 x 3/8 long truss head)	.95 (Pkg. of 5)
R-502	Miscellaneous body structural 3/16 diameter x 3/8 long round head	.95 (Pkg. of 5)
R-503	Miscellaneous body structural full head both sides (3/16 diameter x 5/8 long, round head)	.95 (Pkg. of 5)
R-504	Front cross member (1/4" diameter x 5/8 long flat head)	.70 ea.
R-504 S	Front cross member Kit	6.00
R-505	Front cross member - miscellaneous frame locations (1/4" diameter x 7/8" long round head)	.65 ea.
R-506	Side mount tire brackets - miscellaneous frame locations (5/16 diameter. x 1" long round head)	2.00 (Pkg. of 4)
R-507 S	Floor pan kit (50-3/16 diameter x 1/4" long truss head and 10-3/16 diameter x 3/8" long truss head and 6-3/16 diameter x 1/2" long)	6.00 set
R-508 S	Rear cross member kit	9.00 set
R-509	Running board bracket kit	5.75 set
R-600 A	Rivet setting tool with 3/8" cup diameter. Used with air tool. 1/4" diameter rivets	29.50
R-600 M	Rivet setting tool. Has correct concave head. Cup diameter 1/4" To be used manually 3/16" diameter rivets	18.50
R-600 W	Waffle setting tool, used with air tool.	29.00
R-601 A	Rivet setting tool. 1/4" cup. Used with air tool. 3/16" diameter rivets	31.00
R-601 M	Rivet setting tool. Cup diameter 3/8" Manual. 1/4" diameter rivets	18.50
R-603 T	1/4" Round Head Bucking Bar	19.95
R-605 T	3/16 Brazier Head Bucking Bar	19.95
R-900	PU bed assembly, 1926-52, tail gate hinges 1926-31. Many other uses.	.25 ea.

NUMBER	NAME OF PART	PRICE
280	1928-29 Fordor briggs without quarter windows	24.00
281	1928-29 Fordor briggs with quarter windows	24.00
282	1928-29 Fordor murray with quarter window	24.00
283	1928-29 Roadster	9.25
284	1928-29 Roadster pickup	8.50
285	1928-29 Sport coupe	9.75
286	1928-29 Coupe	11.50
287	1928-29 Tudor	12.75
288	1928-29 Closed cab pickup	13.00
289	1928-29 Cabriolet	17.00
290	1928-29 Phaeton	11.25
300	1930-31 Fordor briggs	29.00
301	1930-31 Fordor murray	25.00
302	1930-31 Fordor slant windshield	26.50
303	1930-31 Roadster	8.50
304	1930-31 Roadster pickup	8.00
305	1930-31 Fordor phaeton	11.25
306	1930-31 Tudor deluxe phaeton	11.25
307	1930-31 Sport coupe	9.75
308	1930-31 Coupe	10.50
309	1930-31 Tudor	13.00
310	1930-31 Cabriolet slant windshield	17.00
311	1930-31 Victoria	19.00
312	1930-31 A-400	21.00
313	1930-31 Cabriolet straight windshield	17.00
314	1930-31 Closed cab pickup	14.00

Chassis Bolt Kits

Clinch Nuts & Cotter Pins

NUMBER	NAME OF PART	PRICE
A-80035	1928-31 Engine bolt kit	13.50
A-80036	1928-31 Transmission & differential kit	11.00
A-80043	1928-29 Fender & running board installation kit	15.95
A-80044	1930-31 Fender & running board installation kit	15.95
A-80045	1928-31 Body to frame mounting bolt kit	6.95

NUMBER	NAME OF PART	PRICE
1123	12/24 Gas tank & floor board clinch nuts	.30 ea.
1123 A	Firewall clinch nuts 10/32	.30 ea.
1123 B	Dash rail clinch nuts 1/4-20	.30 ea.
1123 C	Body sill at spare tire carrier clinch nut 3/8-24	1.60 ea.
1123 D	Fender brace to wheel housing sedan and phaeton clinch nut 5/16-24	1.80
1123 E	7/16-20 Clinch nut. Used on spare tire carrier of 1928-29 Briggs w/4 hole mounting & top support on fordor phaetons.	2.35
1149	Cotter pin set (cadmium plated) 160 pc	6.00 set
1149 S	Cotter pin set stainless steel 160 pc	14.00 set

Door Bumper Sets



NUMBER	NAME OF PART	PRICE
A-702610 AS	Rubber door bumper set, 1925-29, Coupe & Tudor, 10 pieces (and 1928-29 Cabriolet)	11.00
A-702610 BS	Rubber door bumper set, 1930-31, Coupe & Tudor, 10 pieces	11.00
A-702610 CS	Rubber door bumper set, 1928-31, Fordor, 14 pieces	12.95
A-702610 ES	Rubber door bumper set, 1928-29, Roadster, Roadster Pickup, 12 pieces	10.00
A-702610 FS	Rubber door bumper set, 1930-31 Roadster & Deluxe Phaeton & Roadster Pickup 12 pieces	10.00
A-702610 HS	Rubber door bumper set, 1930-31 Cabriolet, 10 pieces, straight windshield	10.00
A-702610 IS	Rubber door bumper set, 1928-29 Sport Coupe & 1930-31 Pickup, & 1930-31 Sport Coupe, 10 Pieces	10.00
A-702610 KS	Rubber door bumper set, 1928-29, Phaeton, 24 pieces	14.00
A-702610 LS	Rubber door bumper set, 1930-31, Phaeton with inside fuel valve, 24 pieces	14.00
A-702610 MS	Rubber door bumper set, 1931 Phaeton with outside fuel valve, 22 pieces, Tudor D/X	14.00



A-702610 DBC



A-702610 DBF

NUMBER	NAME OF PART	PRICE
A-702610 NS	Rubber door bumper set, 1928-29 Pickup, 12 pieces	8.95
A-702610 RS	Rubber door bumper set, 1931 slant windshield Fordor, 16 pieces	22.00
A-702610 SS	Rubber door bumper set, 1928-31 Station Wagon, 20 pieces	Disc.
A-702610 TS	Rubber door bumper set, 1931 slant windshield Cabriolet, 8 pieces	14.00
A-702610 VS	Rubber door bumper set, 1930-31, Victoria & A-400, 8 pieces	15.00
A-702610 DBC	1928-31 Coupe, tudor, and 1930-31 closed cab pickup door bumper clip. Three sided clip that holds the door bumper in place. One needed per door. Spot weld in place	4.75
A-702610 DBF	1928-31 Fordor sedan, cabriolet, 1930-31 Victoria. Two clips needed on each side of door post. Mounts with screws	4.75



Floor Mats



A-700400 A

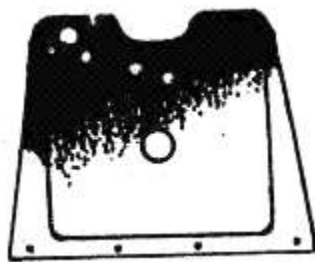

A-700400 B

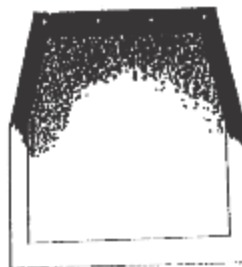

A-700430

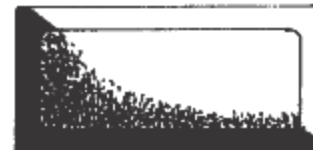

A-700450

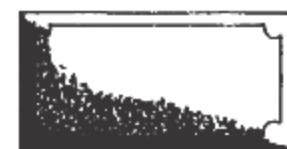

A-700480

NUMBER	NAME OF PART	PRICE
A-700400 A	1928-29 Front floor mat, USA mfg. brake to front	45.00
A-700400 B	Late 1929 & 1930-31 Front floor mats, USA mfg. brake to right	49.50
A-700430	1928-31 Tudor rear mat, USA	55.00

NUMBER	NAME OF PART	PRICE
A-700450	1928-31 Phaeton rear floor mats, fits 1929-31 Cabriolet, import	120.00
A-700480	1928-31 Rumble seat mat	35.00
A-35247	Floor mat stud set - holds floor mat in place	5.50

Deluxe Carpet Sets

We now handle carpets in the original brown square weave wool material. This is a non stocking item and will be shipped from the manufacturer. Carpet sets do NOT include fasteners. **Please call for current pricing.**

NUMBER	NAME OF PART	PRICE	NUMBER	NAME OF PART	PRICE
A-700400 CABN	1928-29 Coupe Front Brown	183.95	A-700430 SABN	1928-29 Tudor Sedan Rear Brown	183.95
A-700400 CBBN	1930-31 Coupe Front Brown	183.95	A-700430 SBBN	1930-31 Tudor Sedan Rear Brown	183.95
A-700400 SABN	1928-29 Sedan Front Brown	183.95	A-35249	1909-31 Nickel carpet snaps - 2 pcs	1.50
A-700400 SBBN	1930-31 Sedan Front Brown	183.95			

"A" Upholstery



We have two upholstery suppliers. One has been a steady supplier for many years and produces quality products. They also have the ability to make kits according to customer desires. The down side is that they do not have high production capacity and often get behind, making for lengthy delivery times. These kits are listed under A-410000 series numbers.

Our other supplier is more production oriented and has a large selection of upholstery kits available. They also produce a quality product with competitive pricing. We have some of their faster moving products listed in our catalog. We will be happy to quote prices on non listed items. These kits are listed under A-540000 series numbers. This supplier is usually prompt and kits will be shipped directly to you under their label

Shipping is not included in the prices of any of our kits and will be added to your order.

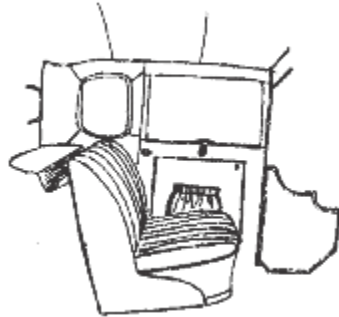

A-4100008 DLX



Seat in A-4100009 DLX

Our upholstery is a lustrous fabric imitating mohair. An excellent quality vinyl is used for the kick panels and rumble seats. No springs are provided, but are available under a separate listing in our catalog. Send \$1.00 for a set of fabric samples. We strive to meet our 8-12 week delivery time. A deposit of 30 percent must accompany the order and the balance is due just prior to shipment. We do not ship upholstery COD. We stand behind our product and will make sure that you are satisfied with it. But we must admit, we have sold more kits at the recommendation of a previous customer than by any other means.

Interior kits include seat upholstery, door panels, cowl kick panels; as well as headliner, upper and lower panels where needed. The seat upholstery comes with its own padding and burlap. Rumble seat covers and panel sets must be ordered separately. All kick panels are glued and stitched. Parts of kits may be ordered separately. Pickup upholstery kit does not include headliner. Headliner can be ordered separately.

Pricing as of January 2011 - subject to change without notice, but not altered once order is placed.

NUMBER	NAME OF PART	PRICE	NUMBER	NAME OF PART	PRICE
MODEL A INTERIOR KITS					
A-4100000 DL	ROADSTER Interior kit, deluxe with pleated seats, 1928-29	500.00	A-4100007 HL	CLOSED CAB PICKUP headliner and rear cab panel, not original 1930-31	350.00
A-4100000 PL	ROADSTER interior kit, plain no pleats or pockets, 1928-29, original style	460.00	A-4100007 HL1	CLOSED CAB PICKUP headliner, steel top pickups upper panel only	175.00
A-4100001 DL	ROADSTER interior kit, deluxe with pockets and pleats 1930-31	675.00	A-4100007 PL	CLOSED CAB PICKUP interior kit, plain no pockets or pleats, 1930-31	460.00
A-4100001 PL	ROADSTER interior kit, plain no pockets or pleats 1930-31	475.00	A-4100008 DLX	COUPE interior kit, 1928-31 (call for price on Bedford cord)	850.00
A-4100002 DL	ROADSTER PICKUP interior kit deluxe with pleated seats and door pockets, 1928-29	450.00	A-4100008 STD	COUPE interior, no pleats, no pockets 1928-31	750.00
A-4100002 PL	ROADSTER PICKUP interior kit plain no pleats or pockets, 1928-29	400.00	A-4100009 DLX	TUDOR SEDAN interior kit with pleats and door pockets, 1928-29	1,350.00
A-4100003 DL	ROADSTER PICKUP interior kit, deluxe with pleated seats and door pockets 1930-31	450.00	A-4100009 DLXB	TUDOR SEDAN interior kit with pleats and pockets 1930-31	1,450.00
A-4100003 PL	ROADSTER PICKUP interior kit, plain no pockets or pleats 1930-31	400.00	A-4100009 STD	TUDOR SEDAN plain seats, no door pockets 1928-29	1,300.00
A-4100004 DL	TOURING interior kit, deluxe with door pockets and pleated seats 1928-29	960.00	A-4100009 STDB	TUDOR SEDAN interior kit with plain seats, no door pockets 1930-31	1,350.00
A-4100004 PL	TOURING interior kit, plain no pockets or pleats 1928-29	900.00	A-4100010	FORDOR SEDAN, straight windshield interior kit, 1928-31 (floor carpeting not included)	1,700.00
A-4100005 DL	TOURING interior kit, deluxe with cowl pockets and pleated seats 1930-31, 4 door	1000.00	A-4100011	FORDOR SEDAN, slant windshield interior kit (floor carpeting not included)	1,800.00
A-4100005 PL	TOURING interior kit, plain no pockets or pleats 1930-31 4 door	900.00	A-4100012	SPORT COUPE interior kit, 1928-31	960.00
A-4100005 PL	TOURING interior kit, deluxe with cowl pockets and narrow pleats 2 door	1200.00	A-4100013	VICTORIA interior kit, 1930-31	1,500.00
A-4100006 DL	CLOSED CAB PICKUP interior kit deluxe with cowl pockets and pleated seats, 1928-29 Headliner sold separately	500.00	A-4100021	STATION WAGON interior kit	1,340.00
A-4100006 HL	CLOSED CAB PICKUP headliner and rear cab panel, not original 1928-29	310.00	A-4100023	CABRIOLET interior kit, 1930-31	800.00
A-4100006 PL	CLOSED CAB PICKUP interior kit plain no pockets or pleats, 1928-29	460.00	RUMBLE SEAT UPHOLSTERY		
A-4100007 DL	CLOSED CAB PICKUP interior kit deluxe with door pockets and pleated seats, 1930-31. Headliner sold separately	500.00	A-4100014	RUMBLE SEAT covering for 2 cushions without pleats, 1928-29	180.00
			A-4100014 A	RUMBLE SEAT upholstery on springs without pleats, 1928-29	700.00
			A-4100014 B	RUMBLE SEAT upholstery on springs with pleats, 1930-31	775.00
			A-4100014 P	RUMBLE SEAT covering for 2 cushions with pleats, 1930-31	260.00

Top Kits



TOPS WITH PLASTIC BACK WINDOW AND NECESSARY PADDING. (TOP IRONS NOT INCLUDED)

NUMBER	NAME OF PART	PRICE	NUMBER	NAME OF PART	PRICE
A-37639 PL	1928-31 Standard open car plain steel rear window frame. 7" x 16 1/2"	160.00 ea.	A-4100018	ROADSTER, black fine cobra grain 1928-29 or 1930-31	375.00
A-37639 SS	1928-31 Deluxe open car, metal rear window frame. Stainless outer rim. 7" x 16 1/2"	179.95 ea.	A-4100018 H	ROADSTER, black or tan Haartz 1928-29	750.00
A-4100004 C	TOURING, 1928-29 - fine black cobra grain	575.00	A-4100019	DELUXE ROADSTER, tan or black Haartz, 1930-31	750.00
A-4100004 H	TOURING, 1928-29 - tan or black Haartz cloth	900.00	A-4100020 H	STANDARD ROADSTER, black or tan Haartz cloth 1930-31 **if stainless framed back window is substituted add \$129.00 to your cost.	750.00
A-4100005 C	TOURING, 1930-31 standard phaeton - fine black cobra grain	575.00	A-4100023 H	CABRIOLET specify year, black or tan Haartz cloth 1928-30	725.00
A-4100005 H	TOURING, 1930-31 standard phaeton - tan or black Haartz cloth	900.00	A-4100024	1928-29 Sport coupe, black fine cobra grain material	500.00
A-4100006 V	CLOSED CAB PICKUP sun-visor kit, 1928-29	45.00	A-4100024 H	1928-29 Sport coupe, tan or black Haartz Stayfast material	725.00
A-4100016	ROADSTER PICKUP, 1928-29 or 1930-31 - fine black cobra grain	375.00	A-4100025	1930-31 Sport coupe, black fine cobra grain material	500.00
A-4100017	ROADSTER PICKUP, 1928-29 or 1930-31 - tan or black Haartz cloth	750.00	A-4100025 H	1930-31 Sport coupe, tan or black Haartz material	725.00

Side Curtains



A-4100029

NUMBER	NAME OF PART	PRICE
A-4100028	1928-29 Roadster side curtains, cobra grain	450.00
A-4100029	1928-29 Touring side curtains, cobra grain	650.00
A-4100030	1930-31 Standard roadster & roadster pu side curtains, cobra grain specify body style	450.00
A-4100031	1930-31 Standard touring side curtains, cobra grain	650.00
A-4100032	1931 Deluxe roadster tan or black stafast material	750.00

Kick Panels



A-40500 A, A-40500 B,
A-40500 AV, A-40500 BV

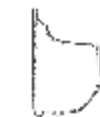

A-40550 A
A-40550 B



A-40551 B

NUMBER	NAME OF PART	PRICE	NUMBER	NAME OF PART	PRICE
Rumble Liner Kits			A-40552 A1	1928-29 Briggs or Murray Fordors; black vinyl covered cowl kick panels	70.00 pr.
A-40500 A	1928-31 Coupes or 1928-29 Roadster; black vinyl covered rumble panel set	130.00 set	A-40552 A2	1928-29 Briggs or Murray Fordors; brown vinyl covered cowl kick panels	70.00 pr.
A-40500 B	1928-31 Coupes or 1928-29 Roadster; brown vinyl covered rumble panel set	130.00 set	A-40552 B1	1930-31 Briggs or Murray Fordors; black vinyl covered cowl kick panels	70.00 pr.
A-40500 AV	1930-31 Roadsters; black vinyl covered rumble panel set	130.00 set	A-40552 B2	1930-31 Briggs or Murray Fordors; brown vinyl covered cowl kick panels	70.00 pr.
A-40500 BV	1930-31 Roadsters; brown vinyl covered rumble panel set	130.00 set	A-40555 C	1928-31 Kick panel retaining clip	5.75 pr.
Cowl Kick Panels - Closed Cars			Cowl Kick Panels - Open Cars		
A-40550 A	1928-29 Coupes, Tudors, or Closed Cab Pickups; black vinyl covered cowl kick panels	70.00 pr.	A-40553 A	1928-29 Roadsters or Roadster Pickups; black vinyl covered cowl kick panels	70.00 pr.
A-40550 B	1928-29 Coupes, Tudors, or Closed Cab Pickups; brown vinyl covered cowl kick panels	70.00 pr.	A-40553 B	1928-29 Roadsters or Roadster Pickups; brown vinyl covered cowl kick panels	70.00 pr.
A-40551 A	1930-31 Coupes, Tudors, or Closed Cab Pickups; black vinyl covered cowl kick panels	70.00 pr.	A-40554 A	1930-31 Roadsters or Roadster Pickups; black vinyl covered cowl kick panels	70.00 pr.
A-40551 B	1930-31 Coupes, Tudors, or Closed Cab Pickups; brown vinyl covered cowl kick panels	70.00 pr.	A-40554 B	1930-31 Roadsters or Roadster Pickups; brown vinyl covered cowl kick panels	70.00 pr.

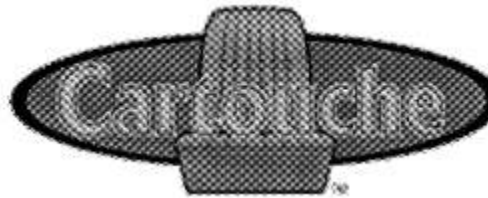

UPHOLSTERY

1928-1931 MODEL A

* Original Licensed Product
With Most Accessories

CARTOUCHE UPHOLSTERY LINE These upholstery kits are available in the original materials and also non-original materials. The prices below are based on the non-original materials. Call for prices on original material for any of the items listed below. Always specify the year and body style of the car you are ordering the kit for. These kits are only made the way they were originally. NO EXCEPTIONS. Pricing as of April 2007-subject to change without notice, but not altered once order placed. Prices do fluctuate. **Please call for current pricing.**

INTERIOR KITS includes everything needed to reupholster the inside of the car. If needed the kit includes headliner, tacks, interior panels, fasteners, clips screws, washers, padded and stitched covers, cotton padding, felt, hog rings, trim, windlace, bow drill and complete instructions.

TOP KITS include the fabric parts needed to replace your old top on original type top iron and bow assembly. They include the main top deck, rear curtain, rear extensions or gypsy wings, bow covering front wind breaker, rear apron when required, straps, welting, etc.

INTERIOR KITS

OPEN CAR WITH PANEL SETS

NUMBER	NAME OF PART	PRICE
A-540001 R	1928-29 Standard Roadster	466.00
A-540001 S	1930-31 Standard Roadster	550.00
A-540001 D	1930-31 Deluxe Roadster	664.00
A-540002 A	1928-29 Roadster Pickup	406.00
A-540002 B	1930-31 Roadster Pickup	406.00
A-540003 P	1928-29 Phaeton	884.00
A-540003 S	1930-31 Standard Phaeton	1,094.00
A-540003 D	1931 Deluxe Tudor Phaeton	1,250.00

RUMBLE INTERIOR

A-540004 A	1928-29 Rumble (All Cars)	308.00
A-540004 S	1930-31 Standard Rumble 4 1/2" pleats	359.00
A-540004 D	1930-31 Deluxe Rumble 2 1/2" pleats	365.00

TOP KITS

CANVAS

NUMBER	NAME OF PART	PRICE
A-540006 T	1928-31 Roadster Pickup Tan	458.00
A-540006 B	1928-31 Roadster Pickup Black	622.00
A-540007 BC	1928-31 Standard Roadster Black	622.00
A-540007 TC	1928-31 Standard Roadster Tan	458.00
A-540008 T	1930-31 Deluxe Roadster Tan	488.00
A-540008 B	1930-31 Deluxe Roadster Black	626.00
A-540009 BC	1928-29 Phaeton Black	900.00
A-540009 TC	1928-31 Phaeton Tan	780.00

VINYL

NUMBER	NAME OF PART	PRICE
A-540007 V	1928-31 Standard Roadster & Roadster Pickup	346.00
A-540008 D	1930-31 Deluxe Roadster	366.00
A-540009 P	1928-31 Phaeton	550.00

SIDE CURTAINS

VINYL

NUMBER	NAME OF PART	PRICE
A-540028	1928-31 Roadster	463.00
A-540031	1928-31 Standard & Deluxe Tudor Phaeton	663.00
A-540034	1928-31 Roadster Pickup	463.00

INTERIOR KITS

CLOSED CAR

NUMBER	NAME OF PART	PRICE
A-540013 P	1928-29 Closed Cab Pickup	478.00
A-540013 D	1930-31 Closed Cab Pickup	478.00
A-540013 L	1931 Late Closed Cab Pickup	478.00
A-540014 STD	1928-29 Standard Coupe	731.00
*A-540014 SC	1928-29 Sport Coupe	780.00
*A-540014 BC	1928-29 Business Coupe	731.00
A-540014 SP	1928-29 Special Coupe	736.00
A-540015 S	1930-31 Standard Coupe	836.00
*A-540015 C	1930-31 Sport Coupe	800.00
A-540015 DLX	1930-31 Deluxe Coupe	950.00
A-540015 CAB	1930-31 Cabriolet	805.00
A-540016 ST	1928-29 Standard Tudor Sedan	1,386.00
A-540016 DT	1930-31 Deluxe Tudor Sedan	1,600.00
A-540017 SF	1928-29 Standard Fordor 1928 Leatherback	1,541.00
A-540017 DF	1928-31 Deluxe Fordor Sedan & Town Sedan	1,860.00
A-540018 V	1931 Victoria	1,600.00

*Top filler pads not included. Add \$75.00 for rear armrest Fordors

CARPET SETS

NUMBER	NAME OF PART	PRICE
A-540090	1928-31 Coupe Front	93.95
A-540091	1928-31 Tudor Sedan Front & Rear	187.90
A-540092	1928-31 Fordor & Town Sedan Front & Rear	187.90
A-540093	1931 Victoria Front & Rear	212.90
A-540094	1931 Cabriolet Front	93.95
A-540096	1931 Slant Windshield Fordor Sedan Front & Rear	187.90

SIDE CURTAINS

CANVAS

NUMBER	NAME OF PART	PRICE
A-540029	1928-31 Roadster Black	580.00
A-540030	1928-31 Roadster Tan	526.00
A-540032	1928-31 Standard or Deluxe Tudor Phaeton Tan, specify Standard or Deluxe	720.00
A-540033	1928-31 Standard & Deluxe Tudor Phaeton Black	894.00
A-540035	1928-31 Roadster Pickup Tan	526.00
A-540036	1928-31 Roadster Pickup Black	580.00

Windshield and Glass for 1928-31 Fords



GLASS: All glass parts are produced using ASI rated safety laminated glass. Overall glass thickness is 7/32" which is compatible with original or replacement glass channels and weather strips. No markings of any type are on any glass parts unless we are specifically requested to do so.

FORD "XXX" WINDSHIELD LOGO: A Duplication of the Ford "XXX" windshield logo is available for all windshields. It is applied with a stencil and is acid etched onto the glass. Placement is in the lower corner of the windshield, reading correctly from outside of the vehicle on the passenger side, unless we are advised differently.

GLASS SETS: Full replacement glass sets include: windshield, side windows and back window. Glass "Sets" should be ordered by set part number and each individual glass part number which apply to the specific vehicle you are ordering a glass set for.

TINTED GLASS: All glass parts can be produced in green tinted glass, add 20% to all prices listed.

A-94100	Model A windshields	115.00
A-94500	Model A front door glass	70.00

BOXING REQUIREMENTS: Total number of boxes required for safe shipments can be calculated by referencing the shipping weights listed for individual parts or sets. A maximum of five parts can be boxed together, with no box exceeding 45 lbs. Windshields always will require a separate box.

SHIPPING WEIGHTS: UPS charges will be calculated and charged.

DAMAGES: In the instance of shipping damage, advise your customer to return the damaged parts to the original container and notify his local UPS office that he has received damaged merchandise. UPS will pick up the parcel and return it to us for processing the claim. Notify us immediately and we will see that the necessary replacements are made on a priority basis.

SHIPPING: All glass will be shipped from the manufacturer to you. Approximate shipping time is 4-6 weeks from date order is placed.

A-94804	Model A rear door glass	70.00
A-94206	Model A quarter window glass (tudors)	80.00
A-94208	Model A rear window open car	58.00
A-94209	Rear quarter window for fordor. Specify body style	58.00
A-94210	Model A rear window closed car	58.00
A-94805	Model A rear roll down window glass coupe	58.00

Body Styles

DESCRIPTION	YEAR	BODY STYLE
Standard Phaeton	1928-29	35-A
Standard Phaeton	1930-31	35-B
Standard Phaeton	1928-29	40-A
Standard Roadster	1930-31	40-B
Deluxe Roadster	1930-31	40-B
Standard. Coupe	1928-29	45-A
Standard Coupe	1930-31	45-B
Deluxe Coupe	1930-31	45-B
Special Coupe	1928-29	49-A
Sports Coupe	1928-29	50-A
Sports. Coupe	1930-31	50-B
Business Coupe	1928-29	54-A
Tudor Sedan	1928-29	55-A
Standard Tudor Sedan	1930-31	55-B
Deluxe Tudor Sedan	1931	55-B
Fordor Leather Back - Briggs Seal Brown Top	1928-29	60-A
Fordor Leather Back - Briggs Black Top	1929	60-B
Fordor Steel Back - Briggs	1929	60-A
Cabriolet	1929	68-A
Cabriolet	1930-31	68-B
Cabriolet	1931	68-C
Taxi-Cab	1928-29	135-A
Town Car	1928-29	140-A
Station Wagon	1928-29	150-A
Station Wagon	1930-31	150-B
Town Sedan - Murray	1929	155-A
Town Sedan - Briggs	1929	155-B
Town Sedan - Murray	1930-31	155-C
Town Sedan - Briggs	1930-31	155-D

DESCRIPTION	YEAR	BODY STYLE
Standard Fordor Sedan	1931	160-A
Town Sedan	1931	160-B
Deluxe Fordor Sedan	1931	160-C
Standard Fordor Sedan - Murray	1929	165-A
Standard Fordor Sedan - Briggs	1929	165-B
Standard Fordor Sedan - Murray	1930-31	165-C
Standard Fordor Sedan - Briggs	1930-31	165-D
Standard Fordor 2 Window Briggs	1929	170-A
Standard Fordor Sedan 2 Window Briggs	1929	170-B
Deluxe Fordor Sedan 2 Window Briggs	1930-31	170-B
Deluxe Phaeton	1930-31	180-A
Victoria	1930-31	190-A
Convertible Sedan	1931	400-A

DESCRIPTION	YEAR	BODY STYLE
Deluxe Pickup	1931	66-A
Open Cab Pickup	1928-30	76-A
Open Cab Pickup	1930-31	76-B
Pickup	1928-31	78-A
Pickup	1931	78-B
A Panel Delivery	1928-30	79-A
A Panel Delivery	1930-31	79-B
Closed Cab Pickup	1928-31	82-A
Closed Cab Pickup	1930-31	82-B
AA Panel Delivery	1928-30	85-A
AA Panel Delivery	1930-31	85-B
Deluxe Delivery	1928-31	130-A
Deluxe 1 Ton Delivery	1930-31	130-B
Deluxe 1 Ton Delivery (Drop Floor)	1930-31	130-B

Nails

NUMBER	NAME OF PART	PRICE	NUMBER	NAME OF PART	PRICE
N-3	Body nails, .074 x 3/4" long oval head (100/pkg.)	1.75 pkg.	N-5	Stainless steel trim & body nails, .085 x 3/4" long oval head (100/pkg.)	3.25 pkg.
N-4	Screw nails .085 x 7/8" long flat head (100/pkg.), top moulding & rain gutter	1.75 pkg.			

Paints



NUMBER	NAME OF PART	PRICE	NUMBER	NAME OF PART	PRICE
M-200 A	Engine green (aerosol)	6.00 can	M-325	POR-PATCH, much like POR-15 except thicker and in a tube. It dries hard, fills well, and is impervious to fuels & solvents, 4 oz.	18.00
M-200 B	Engine green (non-aerosol)	13.50 pint	M-400	Ultra black silicone RTV Hi-Temp gasket maker	5.00
M-205	Black lacquer carburetor paint	7.50	M-800	Gas tank sealer, resistant to all fuels, alcohol, additives and solvents. Stops rust, corrosion and leaks permanently. Chemically bonds to metal surfaces. Tank must be cleaned with a degreaser and treated with Metal Ready prior to use	39.00 qt.
M-250	Engine black (aerosol)	4.00 can	M-800 X	Prep & Ready provides good adhesion on any surface. Gently etches metal and neutralized rust for good adhesion of paint and gas tank sealer.	17.50 qt.
M-255	Black high heat resistant 1200 degree	6.00 can	M-800 XG	Prep & Ready same as above in gallon	33.50 gl.
M-258	Aluminum color high heat paint 1200 degree	6.00 can	M-813	Marine Clean Degreaser	11.50 qt
M-260	Cast color (aerosol) high heat	6.00 can	M-825	Rust Cure - Dissolves rust and leaves cured surface for paint (usually dissolves rust in 30 minutes or less).	12.00 qt.
M-300	Designed to be coated right onto rusty surfaces leaving a beautiful rock hard finish, black, POR-15	47.00 qt.			
M-301	POR-15 Solvent, Formulated for cleanup or thinning of POR-15	13.00 qt.			
M-310	Black Cote, designed to be used over POR-15 on chassis. Provides UV protection. High gloss	48.00 qt			
M-311	Black Cote same as above except is satiny semi-gloss. Chassis coat black. POR-15	48.00 qt.			
M-320	Tie coat primer. Easily paints over cured POR-15 using this primer	31.00 qt.			

Lubricants And Additives

NUMBER	NAME OF PART	PRICE	NUMBER	NAME OF PART	PRICE
M-600 K	The best penetrating oil we have found. Loosens stuck together metal parts. Prevents rust. Removes gummed oil, grease and rust. Lubricates air tools. 8 oz. can.	6.00	M-625	STA-BIL concentrated fuel stabilizer - Marine formula, 8 oz.	8.00
M-600 Q	600 weight gear oil - heavy clinging type - usually takes a little over 2 quarts for a car	7.95 qt.	M-630	CRC Brakleen Aerosol - Brake parts cleaner 20 oz.	3.00
M-600 G	Same as above in gallons	29.00 gal	M-632	Master non-chlorinated brake cleaner, 15 oz.	3.00
M-602	SAE 20 non-detergent motor oil	4.00 qt.	M-640	Master carburetor cleaner, 16 oz.	3.50
M-604	SAE 40 non-detergent motor oil	4.00 qt.	A-8501 SPG	STA-PUT - The best water pump grease that we have found. Withstands extreme pressure, high temperature and is water proof. Superior product, recommended for chassis wheel bearing, water pump and universal joint lubrication, 14 oz. tube	6.00
M-610 S	STP oil treatment, 15 oz.	4.00	GREASE	TIMKEN Wheel bearing grease, 16 oz.	5.00
M-616	Sea Foam motor treatment, 16 oz.	8.00			
M-620	Marvel Mystery Oil	4.00 pt.			

****Please note that UPS considers these products hazardous and charges an extra \$5.00 for an order carrying these products.**

Polish

MET-ALL polish is a high quality USA made product and is as good or better than anything on the market today at a competitive price.

NUMBER	NAME OF PART	PRICE
M-850	Brass & copper polish. Gives brass a high shine. Cleans, polishes and protects in one easy application. Non-abrasive and non-toxic. 2.5 oz. tube	5.50
M-860	High performance racing polish that shines chrome, stainless and aluminum. It cleans, polishes and protects bumpers, radiator shells, headlights, etc. Non-toxic and non-abrasive. Deep cleans to remove stubborn oxidation and water spots. 2.5 oz. tube	5.50
M-861	Racing polish same as above in 16 oz. can	9.50



M-850



M-860



M-861

A SPEEDSTER KIT

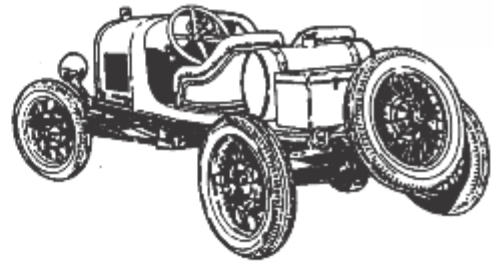
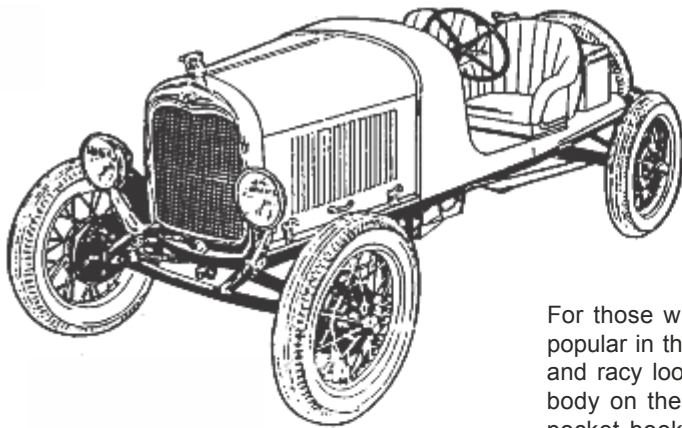

For those who prefer the open wheel style of the dirt-track racers so popular in the 1920's & 1930's, we offer the body only kit. With its lean and racy look it draws attention everywhere it goes. The best A racer body on the market today, in terms of ease of construction, ease on pocket book and most important – it will give you the satisfaction of building a car you can be proud of. Full assembly instructions now come with the body, making it perfect for the beginning enthusiast. Order now, so you will be ready to spend next season with the wind in your hair and the crisp note of the exhaust in your ear.

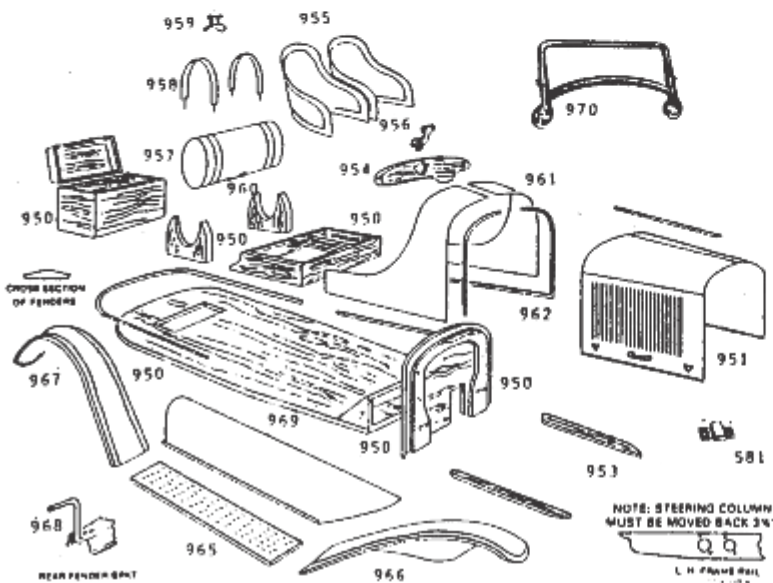

NO. 905 BODY KIT ONLY

(Includes parts 950 through 962)

\$2,890.00

NO. 900 COMPLETE A SPEEDSTER KIT

(Includes parts 950 through 970)

\$4,960.00

NO. 950	Deck, floorboard & risers, seat risers, tank blocks, firewall & tool box	1,450.00	NO. 959	Brass filler neck	200.00
NO. 951	Hood	475.00	NO. 960	Brass lower gas outlet	15.00
NO. 581	Center hinge bracket (need 2)	10.00 ea.	NO. 961	Metal cowl	155.00
NO. 953	Hood blocks	70.00	NO. 962	3/4" molding (36 feet)	150.00
NO. 954	Dash	85.00	NO. 965	Running boards (pair)	190.00
NO. 955	Seat skins w/wooden base	260.00	NO. 966	Front fenders (pair)	820.00
NO. 956	Steering column bracket	55.00	NO. 967	Rear fenders	610.00
NO. 957	Gas Tank	225.00	NO. 968	Rear fender bracket (pair)	50.00
NO. 958	Tank straps (pair)	75.00	NO. 969	Splash aprons (pair)	150.00
			NO. 970	Windshield frame, chrome, 9 1/2" or 12 1/2" or 15 1/2" tall	400.00

All kits shipped by truck freight collect from California.

AA Ford Truck Parts



NUMBER	NAME OF PART	PRICE	NUMBER	NAME OF PART	PRICE
AA-1118	1930-31 Rear Wheel Bolts, RH Thread	6.95 ea.	AA-5777	1928-31 Rear Spring Shackle Bolt	37.95 ea.
AA-1119	1930-31 Rear Wheel Bolts, LH Thread	6.95 ea.	AA-5778	1928-31 Rear Shackle Bolt Nut	8.00 ea.
AA-1120	1930-31 Front Wheel Nuts, RH Thread	2.50 ea.	AA-5782	1928-31 Rear Spring Upper Shackle Bolt/ Lock Washers	15.00 pr.
AA-1120 AR	1928-29 Acorn Style Wheel Nuts, Cadmium, RH Thread	4.50 ea.	AA-5783 K	1928-31 Rear Axle Bumper Set w/Hardware	89.25 set
AA-1121 AR	1928-29 Acorn Style Wheel Nuts, Cadmium, LH Thread	4.90 ea.	AA-5785 AMS	1928-Early 1929 Rear Spring Pivot Bracket Mounting Rivets (10 pcs. for two brackets)	16.95 set
AA-1121	1930-31 Front Wheel Nuts, LH Thread	2.50 ea.	AA-5785 BMS	Mid 1929-31 Rear Spring Pivot Bracket Mounting Rivets (18 pcs. for two brackets)	18.50 set
AA-1124	1930-31 Rear Hub Washers, hardened, bevel gear type	Disc.	AA-5788 AMS	1928-Early 1929 Rear Spring Pivot Special Washers, Nuts, and Cotter Pins (6 pcs. 3/4" thread)	46.95 set
AA-1132 RH	1930-31 Inner Rear Wheel Nut, RH Thread	3.25 ea.	AA-5788 BMS	Mid 1929-30 Rear Spring Pivot Special Washers, Nuts, and Cotter Pins (6 pcs. 7/8" thread)	37.00 set
AA-1132 LH	1930-31 Inner Rear Wheel Nut, LH Thread	3.75 ea.	AA-5788 CMS	Late 1930-31 Rear Spring Pivot Special Washers, Nuts, and Cotter Pins (6 pcs. 7/8" thread)	38.75 set
AA-1134	1930-31 Rear Wheel Nuts, RH Thread	2.50 ea.	AA-5790 B	1928-31 Rear Spring Pivot Seat Bushings	43.50 pr.
AA-1135	1930-31 Rear Wheel Nuts, LH Thread	2.50 ea.	AA-5791	1928-31 Rear Spring Shackle Bushing (bronze w/grease hole and groove)	24.50 ea.
AA-1175 A	1930-31 Rear Wheel Hub Seals	7.95 ea.	AA-5798	1928-31 Rear Spring Seat Lock Pin w/Lock Washers & Nut	7.50 ea.
AA-1201 AR	1928-29 Front Wheel Inner Bearing	54.00 ea.	AA-5799	1928-31 Rear Spring Set Pin	22.95 ea.
AA-1201	1930-31 Front Wheel Inner Bearing	23.50 ea.	AA-6730 AR	Early 1928 Dual High Drain Plug, Brass (same as oil pan plug)	9.25 ea.
AA-1202 AR	1928-29 Front Wheel Inner Race	22.00 ea.	AA-7153	Late 1929-31 Transmission Gasket Set	18.00 set
AA-1202	1930-31 Front Wheel Inner Race	21.50 ea.	AA-7223	Late 1929-31 Gear Shift Housing Gasket (4 speed)	3.50 ea.
AA-1216 AR	1928-29 Front Wheel Outer Bearing	28.00 ea.	AA-7506	Late 1929-31 Clutch and Brake Pedal Shaft (4 speed)	15.00 ea.
AA-1216	1930-31 Front Wheel Outer Bearing	24.00 ea.	AA-7509 B	1929-31 Pedal Shaft Collar Pin	2.75 ea.
AA-1217 AR	1928-29 Front Wheel Outer Race	15.00 ea.	AA-7510	Late 1929-31 Clutch Release Shaft (4 speed)	16.00 ea.
AA-1217	1930-31 Front Wheel Outer Race	16.00 ea.	AA-7523	Late 1929-31 Clutch Pedal Spring (4 speed)	15.00 ea.
AA-2041	1928-31 Brake Wedge NOS	28.00 ea.	AA-7562	Late 1929-31 Clutch Release Bearing Spring (4 speed)	4.00 ea.
AA-2042	1928-31 Brake adjusting shaft, NOS	20.00	AA-13510 B	Mid 1929-31 Stop Light Switch Operating Finger	18.00 ea.
AA-2233	1928-31 Rear Brake Camshaft Springs	5.00 pr.	AA-13511	Oct. 1930-31 Stop Light Switch Operating Chain & Clamp	16.00 ea.
AA-2234	1928-31 Rear Brake Camshaft Dust Rings	4.50 pr.	AA-14578	1928-31 Headlight Wire Conduit (Black loom w/crimped ends to house the wire running from the radiator shell to the headlamp)	14.00 ea.
AA-2499 D	1930-31 Rear Brake Rod, 65-5/16" long	23.00 ea.	AA-14582	1928-31 Horn Wire Conduit (Black loom w/crimped ends to house the wire running from the radiator shell to the horn)	15.00 ea.
AA-2501 A	1930-31 Front Brake Rod, 61-5/8" long	23.00 ea.	AA-17266	1928-31 Speedometer Cable Grommet	15.95 pr.
AA-2864 B	1930-31 Emergency Brake Rod, 63-5/8" long	25.00 ea.	AA-17701	1928-30 Mirror Head Bolt (Special domed head bolt that holds mirror head to the arm on outside mirror)	4.25 ea.
AA-3111	1930-31 Spindle Bolt Kit	135.00 ea.	AA-20735	1928-31 Rear Spring Tie Bolts	3.50 pr.
AA-4035 ARS	1928-29 Worm Drive Rear Axle Housing Gasket Set	16.50 set	AA-20796 S3	Mid 1928-Early 1930 Special Cap Screw for Clamping Mirror Head to Mirror Bracket	4.00 ea.
AA-4035 BGS	1930-31 Rear Axle Housing & Pinion Gasket Set	17.95 set	AA-21320	1928-31 Rear Spring Shackle Bolt (hex)	Disc.
AA-4221	1930-31 Differential Bearing	36.00 ea.	AA-21921	1928-31 Nut for Rear Spring Shackle Bolt	Disc.
AA-4222	1930-31 Differential Bearing Race	14.00 ea.	AA-21941	1928-29 Rear Axle Nut (worm drive)	Disc.
AA-4243 AR	1928-29 Axle Keys	6.25 pr.	AA-22411 R	1928-29 Rear Hub Gasket, Oil Retaining, Under Washer (worm drive and bevel gear type)	Disc.
AA-4243 B	1930-31 Axle Keys	8.00 pr.	AA-22421 R	1928-29 Rear Hub Washers, Hardened (worm drive and bevel gear type)	Disc.
AA-4245	1928-29 Rear Axle Nut (used with worm drive rear end)	10.95 ea.	AA-22438	1928-29 Coupling Shaft Housing Felt Washer	Disc.
AA-4245 AR	1928-29 Rear Axle Outer Grease Retainer (worm & bevel)	17.00 ea.	AA-23781	Late 1929-31 Pin for Clutch and Brake Pedal Collar (This is the same pin for the cars and trucks with the multiple disc clutch 1928)	Disc.
AA-4245 D	1930-31 Rear Axle Housing Grease Retainer (bevel)	11.00 ea.			
AA-4515 GS	1928-31 Rear Universal Joint Gasket Set	4.75 set			
AA-4521 AR	1928-29 Universal Joint Housing Cap Shim	9.95 ea.			
AA-4616	1930-31 Pinion Bearing Race	25.00 ea.			
AA-4621	1930-31 Pinion Bearing	38.95 ea.			
AA-4625	1930-31 Pinion Pilot Bearing & Race	45.95 ea.			
AA-4629	1930-31 Driving Pinion Pilot Bearing Retainer w/Rivets (bevel gear axle)	9.95 ea.			
AA-4645	1928-31 Drive Shaft Roller Bearing	31.20 ea.			
AA-4700 R	1928-29 Worm Grease Retainer Assembly (worm drive)	15.00 ea.			
AA-4809	Late 1929-Early 1931 Coupling Shaft Housing Packing	6.75 pr.			
AA-4809 L	Late 1931 Coupling Shaft Housing Seal Kit	8.50 set			
AA-4830 GS	1928-29 Dual High Transmission Gasket Set	16.00 set			
AA-5256 AR	1928-Early 1930 Muffler Outlet Pipe Bracket w/hardware	32.00 ea.			
AA-5706	1928-Mid 1929 Rear Spring Clip Spacer	15.40 ea.			
AA-5706 B	Late 1929-31 Rear Spring Clip Bar Spacer	15.40 ea.			
AA-5775 MS	1928-31 Rear Spring, Front Shackle Bracket Mounting Rivets, (8 pc. for two brackets)	13.00 set			

Engines

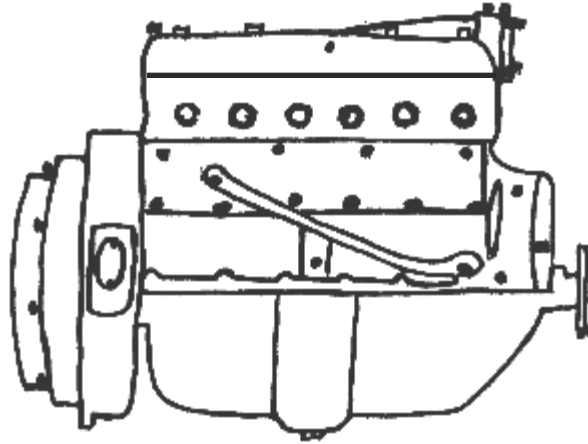

NUMBER	NAME OF PART	PRICE
A-6000 RB2	<p>Rebuilt engine with all new and/or refurbished parts. Long block complete with head and pan installed. Resurfaced flywheel and pressure plate balanced. Completely assembled with flywheel housing, flywheel, clutch disc mounted and pilot bearing installed. Engines are run on a test stand and checked thoroughly.</p>	3,350.00
	<p>We must have a rebuildable core or additional \$500.00 core charge to cover core expenses. If you do not send your core first then we require \$500.00 up front with the cost of the engine. Any unacceptable core parts will be deducted from the \$500.00 core refund or you will be given an opportunity to replace them. Engines that have been exposed to the elements for years and are extremely rusted are not acceptable</p>	600.00
	<p>Engines must be shipped by motor freight. Shipping weight is approximately 500 pounds. Customer is responsible for all freight charge for engine shipping and core or warranty returns.</p>	Freight on engine depends on destination.
	<p>A crating fee of \$100.00 will be charged in addition to the freight charges. If the core is returned in the same crate used to ship the engine, the crating fee will be refunded.</p>	100.00
	<p>In the case of a defect Smith & Jones does not assume any responsibility for costs incurred in removing or installing the engine. Engine will be returned at customers expense for warranty.</p>	

Insulation



NUMBER	NAME OF PART	PRICE
HR-700770	Space age insulation, 300 degree fire resistant pad with aluminum shield that reflects heat, cold and moisture. Can be used for headliners, turnks, kick panels, rumble seat floor, inside door panels and under carpeting. 48" x 72" x 5/16"	31.00

Moulded Firewall Insulation

Moulded insulation that fits firewall on inside of car to reduce heat. Has black plastic covering.

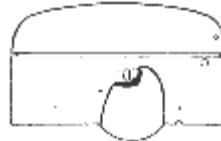

A-18572 A

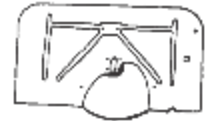

A-18572 B

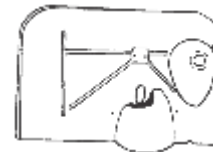

A-18572 C

NUMBER	NAME OF PART	PRICE
A-18572 A	1928-29	135.00
A-18752 B	1930-31, without indentation	135.00
A-18752 C	Late 1931, indented firewall	135.00

Acousti Shield Insulation

NUMBER	NAME OF PART	PRICE	NUMBER	NAME OF PART	PRICE
HR-700330	1928-29 Tudor Sedan complete insulation and sound deadener panel kit	451.00	HR-700240	1928-29 Roadster complete insulation and sound deadener panel kit	362.00
HR-700340	1930-31 Tudor Sedan complete insulation and sound deadener panel kit	451.00	HR-700250	1930-31 Roadster complete insulation and sound deadener panel kit	362.00
HR-700350	1928-29 Fordor Sedan complete insulation and sound deadener panel kit	500.00	HR-700260	1928-29 Phaeton complete insulation and sound deadener panel kit	387.00
HR-700360	1930-31 Fordor Sedan complete insulation and sound deadener panel kit	500.00	HR-700270	1930-31 Phaeton complete insulation and sound deadener panel kit	387.00
HR-700370	1928-29 Fordor Town Sedan complete insulation sound deadener panel kit	500.00	HR-700280	1929 Cabriolet complete insulation and sound deadener panel kit	384.00
HR-700380	1930-31 Fordor Town Sedan complete insulation and sound deadener panel kit	500.00	HR-700290	1930-31 Cabriolet complete insulation and sound deadener panel kit	384.00
			HR-700300	1928-29 Coupe complete insulation and sound deadener panel kit	483.00
			HR-700310	1930-31 Coupe complete insulation and sound deadener panel kit	483.00
			HR-700320	1930-31 Victoria complete insulation and sound deadener panel kit	451.00

Model T Tools



NUMBER	NAME OF PART	PRICE	NUMBER	NAME OF PART	PRICE
R-600 A	Rivet setting air tool 3/8" cup diameter, for 1/4" diameter rivets	29.50	T-2990 T	Tool for drilling cotter pin holes in bolts	36.00
R-600 M	Rivet setting tool manual 1/4" cup diameter, for 1/4" diameter rivets	18.50	T-3009 T	Timer cover alignment tool	13.50
R-600 W	Rivet setting air tool waffle style	29.00	T-3052 TG	Valve timing tool	16.75
R-601 A	Rivet setting air tool 1/4" cup diameter, for 3/16" diameter rivets	31.00	T-3053 T	Valve spring tool	25.00
R-601 M	Rivet setting manual tool 3/8" cup diameter, for 3/16" diameter rivets	18.50	T-3251	Magneto gap gauge tool	200.00
T-1349 X	Wrench that fits spindle nuts, hub caps, wheel bearing, & spark plugs	5.20	T-3300 BT	Band holding tool and wrench	15.00
X-2018	Riveting tool	24.95	T-3368	Crankshaft alignment tool	32.50
A-2021 RIV-T	Set of punches used to set & roll tubular rivets	9.50	T-3413 BT	Band changing tool	8.50
X-2559	1909-27 Brake camshaft bushing driver	14.50	T-3423 PL	Band lining split rivet setting pliers (Holds, splits, curls, & imbeds rivets)	30.00
			T-3423 T	Band changing rivet tool	21.95
			T-3536	Carburetor and timer control rod bending tool	16.95
			T-5200 PP	Piston position sensor tool	3.00
			X-9030 M	Magnetic pickup tool - helps when trying to Remove rust from tank	15.00

Model A Tools

NUMBER	NAME OF PART	PRICE	NUMBER	NAME OF PART	PRICE
R-600 A	Rivet setting air tool 3/8" cup diameter, for 1/4" diameter rivets	29.50	A-7225	Transmission tower rebuild tool kit	160.00
R-600 M	Rivet setting tool manual 1/4" cup diameter, for 1/4" diameter rivets	18.50	A-7550 T	Clutch disc alignment tool	3.95
R-600 W	Rivet setting air tool waffle style	29.00	X-8500	Water pump wrench	1.50
R-601 A	Rivet setting air tool 1/4" cup diameter, for 3/16" diameter rivets	31.00	A-8600 KO	Fan blade knock off tool, help in removing fan	2.40
R-601 M	Rivet setting manual tool 3/8" cup diameter, for 3/16" diameter rivets	18.50	X-9020 T	Gas tank filler screen tool	4.25
A-1109 T	Stud Installation tool	8.00	X-9030 M	Magnetic pickup tool - helps when trying to Remove rust from tank	15.00
A-1130 D3T	Tool to allow the 30-31 hub cap with liner to Install without the removal of the wheel	60.00	X-9300 HD	Heavy duty gas gauge tool	10.95
X-2018	Riveting tool	24.95	A-9511	1928-33 Zenith carburetor jet rebuilding wrench with double end	12.25
A-2021 RIV-T	Set of punches used to set & roll tubular rivets	9.50	X-11350 T	Barrel drive compressor tool	16.00
A-2041 T	Brake adjustment socket tool	9.00	A-12210 CX	Distributor cam timing tool, makes timing easy	9.75
B-2228 T	1928-34 Brake and shackle bushing tool	10.50	A-13300 X	Cowl light marking tool, locates center point for drilling	3.50
X-2450	Adjusting tool brake buddy	23.00	A-17019 A	Tire Iron - Suitable for use or display - Tempered steel - Used through July 1928	18.25
X-3300	Tie rod end tool	4.50	A-17019 B	Tire Iron - Same as above, used from July 28 to November 1928	18.25
X-3528	Throttle/spark removal tool	12.25	A-17019 C	Tire Iron - Same as above, used from November 1928 until end of production	22.00
A-3601 T	Steering wheel removal tool	43.00	A-37101 T	Body curtain socket tool	2.00
B-3643 T	1928-39 Light switch spider tool	7.00	A-37105 T	Side curtain stud tool	16.50
A-4246	Tool used to install A-4245	8.50	A-46335 HPRT	Hinge pin removal tool	35.00
X-4650	Pinion nut wrench	14.00	X-353000 S	Grease Gun Adapter	3.95
A-6001 R	Engine lift ring fits in spark plug hole	10.50	353030 M	Modern grease fitting driver	2.25
A-6010 P	1928-31 Head-puller. Tool used to remove stuck heads from the block. Can also be used to lift engine	85.00	353030 T	Original style grease fitting driver	3.25
X-6052	U-shaped head nut wrench	30.00			
A-6251	Camshaft nut tool	16.95			
A-6319 T	Crankshaft ratchet nut tool	36.00			
B-6500 K	Valve guide tool	8.00			
B-6500 KRW	KRW valve guide tool for original valve	15.75			
X-6512	Valve compression tool	31.00			

1932 Model B Parts



NUMBER	NAME OF PART	PRICE	NUMBER	NAME OF PART	PRICE
B-1130 4SS	1932 SS Hub cap (4 cylinder with ford logo)	19.00 ea.	A-4235	1928-32 Rear axle shaft	350.00 ea.
B-1139	1931-35 Screw-in dust cap	5.50 ea.	A-4242	1928-48 Rear axle nut & cotter pin	1.45 set.
B-1175	1928-38 Rear grease seal	3.75 ea.	A-4245	1928-48 Driveshaft & inner axle seal	2.25 ea.
B-1180	1928-38 Rear wheel seal snap ring, also used with B-7025	1.70 ea.	B-4616	1928-34 Double pinion bearing cup	57.00 ea.
B-1190	1928-34 Front wheel seal	2.25 ea.	B-4634	1928-32 Pinion bearing nut	3.25 ea.
B-1195	1928-54 Front hub grease retainer washer	1.15 ea.	B-4636	1928-47 Pinion lock washer	2.00 ea.
B-1201	1928-48 Front wheel inner bearing USA	16.75 ea.	B-4645	1928-48 Driveshaft bearing	14.75 ea.
B-1202	1928-48 Front wheel inner race USA	10.00 ea.	B-4655	1928-48 Driveshaft bearing sleeve	6.00 ea.
B-1216	1928-48 Front wheel outer bearing USA	17.00 ea.	B-5000	Body to frame webbing (19 ft)	16.00 roll
B-1217	1828-48 Front wheel outer race USA	7.80 ea.	B-5000 SH	Body mounting shim 2" x 1 1/2" with 5/8" slot 1/8" thick	.55 ea.
B-1225 A	1928-36 Rear wheel bearing	28.50 ea.	B-5000 SHK	Body mounting shims 2" x 1 1/2" with 5/8" slot 1/8" thick - set of 10	5.00 set
B-2023	1928-34 Heat treated cadmium plated brake shoe rollers - 16 pcs	1.05 ea. 16.00 set	B-5330 SS	1928-34 Front spring clamps stainless steel	12.00 pr.
B-2045	1928-34 Brake shoe roller pins - 8 pcs	2.95 set	B-5455 BT	1928-34 Front spring u-bolt castellated nut set	3.50 set
B-2050	1928-34 Brake operating wedge	18.00 ea.	B-6008 C	1932 Engine gasket set	39.95 set
B-2051	1928-34 Front brake operating wedge stud	6.75 ea.	B-6031 SRRE	1932 Style front motor mount bolt & rubber kit	28.00 set
B-2051 EQ	1928-34 Floating wedge bolt set. Increases brake power by allowing front brake shoes to equalize pressure.	24.95 set	B-6032 S	32 Style modern front motor mount Float-A-Motor	60.00 set
A-2051 EQI	1928-34 New improved self energizing brake floater system. Increases brake pressure mechanically on brake shoes for safe stops.	160.00 set	B-6051 AS	1932 Style asbestos head gasket	28.00 ea.
B-2052	1928-34 Front brake operating wedge stud washer	1.35 ea.	B-6051 BM	1932 Head gasket with silicon adhesive	31.00 ea.
B-2082	1928-36 Front brake shaft bushings Set of 4.	.60 ea. 2.35 set	BB-6108	1928-34 Good quality aluminum USA manufactured pistons. 3 ring type. State size: STD, .020, .030, .040, .060, .080, .100, or .125	88.00 set
B-2087 S/2234	1928-36 Front & rear brake lever dust rings	1.25 set	B-6149	1928-34 Piston rings. 3 ring rail type. STD, .020, .030, .040, .060, .080, .100, or .125	28.00 set
B-2227	1928-34 Rear brake camshaft bushings for Service and emergency brake shaft in rear housing - 8 pcs	1.00 ea. 8.00 set	B-6200	1932 Rebabbed connecting rods STD. B, .010 B, .020 B, .030 B, .040 B. EXCHANGE ONLY! Sets are balanced	280.00 set
B-2228 T	1928-34 Brake and shackle bushing tool	10.50 ea.	B-6250 BN	1932-34 New camshaft (will fit 1928-31 also)	435.00 ea.
B-2230	1928-34 Rear brake cam, USA	6.75 ea.	B-6256 AL	1928-34 Aluminum camshaft gear - STD	62.00 ea.
B-2231 A	1928-34 Rear brake camshaft	10.35 ea.	B-6256 STD	1928-34 Fiber camshaft gear - STD	38.00 ea.
B-3281	1928-34 Tie rod	16.00 ea.	B-6256 .003	1928-34 Fiber camshaft gear - .003	38.00 ea.
B-3285	1928-34 Right hand tie rod end housing	17.50 ea.	B-6256 .005	1928-34 Fiber camshaft gear - .005	38.00 ea.
B-3286	1928-34 Left hand tie rod end housing	17.50 ea.	B-6256 L STD	1928-34 Laminated fiber camshaft gear - STD	49.00 ea.
B-3305 RK	1928-34 Tie rod or drag link kit - 2 kits per car	10.50 set	B-6256 L .003	1928-34 Laminated fiber camshaft gear - .003	49.00 ea.
B-3332	1928-37 Rubber seal for tie rod & drag link	3.00 set	B-6256 L .005	1928-34 Laminated fiber camshaft gear - .005	49.00 ea.
B-3333	1928-37 Metal seal for tie rod & drag link	3.00 set	B-6259	1928-34 Camshaft Nut	4.75 ea.
B-3552	1929-36 Steering worm bearing lower race	15.25 ea.	B-6275/76	1928-34 Camshaft plunger and spring	3.95 set
B-3616	1932 Light switch rod 42 1/2"	57.00 ea.	B-6306	1928-34 Steel crankshaft gear	13.50 ea.
B-3642	1928-39 Light switch spider spring	.65 ea.	B-6310	1928-34 Crankshaft oil slinger	2.75 ea.
B-3643	1928-39 Light switch spider	3.25 ea.	A-6312	1928-32 Crankshaft pulley - 1 piece	23.50 ea.
B-3643 T	1928-39 Light switch spider tool	7.00 ea.	B-6312 A	1928-32 Crankshaft pulley - 2 piece	29.50 set
B-3644	1928-39 Light switch spider retainer	.40 ea.	B-6328	1932-34 Rear main bearing tube 3/8"	10.00 ea.
B-3647	1928-36 Light switch spider bail	1.75 ea.	B-6346/47	1932-34 Main bearing shim set	12.50 set
B-11655 S	1928-39 Light switch body and housing	17.75 ea.	B-6375 ML	1928-32 Resurfaced & balanced flywheel cut down with V8 pressure plate, pilot bearing, ring gear, & bolts (flywheel core required) (20-25 lbs lighter than original)	475.00 ea.
B-4012	1928-48 Axle housing repair sleeve	24.50 ea.	B-6375 V	1928-32 Resurfaced & balanced flywheel cut down with V8 pressure plate, pilot bearing, ring gear, & bolts (flywheel core required) (10-15 lbs lighter than original)	380.00 ea.
B-4030	1928-48 Differential drain plug	.65 ea.	B-6376	1928-48 Flywheel bolt with hole for safety wire	7.00 set
B-4035	1928-32 Rear end housing gasket .010 thick	1.25 ea.	B-6384	1928-48 Flywheel ring gear	24.95 ea.
B-4035 G6	1928-32 Rear end housing gasket .006 thick	1.25 ea.	B-6400	1928-34 Flywheel housing shim	.50 ea.
B-4221	1928-32 Differential bearing - 4 required	39.00 ea.			
B-4221 SH	1928-48 Differential carrier bearing shim .005 thick	1.00 ea.			
B-4222	1928-32 Differential bearing cup - 2 required	25.00 ea.			

1932 Model B Parts



NUMBER	NAME OF PART	PRICE	NUMBER	NAME OF PART	PRICE
B-6500 K	1928-34 Valve guide tool	8.00 ea.	B-8620 R	1928-34 Wrapped fan belt	9.50 ea.
B-6500 KRW	1928-34 KRW valve guide tool for original valve	15.75 ea.	B-9349 KIT	1932 Fuel pump kit	37.95 set
B-6505 RE SET	1928-34 Modern valve kit with larger head stainless steel valves, one piece valve guides, valve keepers, and 2 piece locks	135.00 set	B-9349 PUMP	1932 Reconditioned fuel pump	160.00 ea.
B-6505 SS	1928-34 Stainless steel valve - original mushroom stem	8.50 ea.	B-9398	1932 Fuel pump diaphragm	4.75 ea.
B-6505 SSX	1928-34 Stainless steel modern day valve used in modern valve set	9.95 ea.	B-9433 A	1928-34 2 Piece asbestos manifold gaskets	2.75 set
B-6506	1928-34 Hardened valve seats	3.50 ea.	B-9433 B	1928-34 1 Piece asbestos manifold gasket with metal on one side	4.95 ea.
B-6506 S	1928-34 Modern hardened valve seats used in modern valve sets	3.50 ea.	A-9433 C	1928-34 2 Piece copper manifold gaskets	12.50 set
B-6510	1928-34 Valve Guides	6.75 ea.	A-9433 C2	1928-34 Later style 2 piece copper manifold Gaskets	12.50 set
B-6510 X	1928-34 One piece valve guide stainless steel for modern valve	3.25 ea.	B-9440	1928-34 Gland rings for exhaust manifold	2.75 set
B-6513	1928-34 Valve springs	6.50 set	B-9443	1928-34 Manifold stud, washer, & nut set	5.75 set
B-6514	1928-34 Valve keeper	1.80 ea.	A-9502 B	1932-34 Zenith carburetor gasket set	1.50 set
B-6514 L	1928-34 Modern valve 2 piece locks used in modern valve sets - 1 set does 1 valve	.40 set	B-9550	1932 Zenith carburetor float	16.00 ea.
B-6514 X	1928-34 Keeper for modern valve set	2.25 ea.	A-9564 ZB	1932-34 Zenith carburetor grose jet	18.00 ea.
B-6521	1932-34 Valve cover gasket	3.50 ea.	B-9595	1932 Zenith carburetor rebuild kit	49.00 set
B-6551 .004	1928-34 .004 Oversized oil pump drive gear	24.95 ea.	B-12199	1932 - 4 Cylinder point set	24.00 set
B-6551 .010	1928-34 .010 Oversized oil pump drive gear	24.95 ea.	B-12300	1932 - 4 Cylinder Condenser	13.95 ea.
B-6551 US	1928-34 Oil pump drive gear USA	25.50 ea.	B-13401 SS	1932-48 License frame back plate - stainless steel - louvered	9.95 ea.
B-6561	1928-34 Oil pump drive gear sleeve	4.75 ea.	B-14487 A	Female wire connectors for bullet ends 10 ct	3.75 set
B-6570	1928-34 Oil pump drive gear spring	1.50 ea.	B-14487 CR	Replacement bullet ends - crimp type 10 ct	2.50 set
B-6600	1928-34 Oil pump rebuild kit - USA with solid bushings	25.00 set	B-14487 E	Replacement bullet ends - solder type 10 ct	3.00 set
B-6600 RB	1928-34 Rebuilt oil pump (core required)	65.00 ea.	B-16070 B	1928-56 Black fender welt (25 ft)	14.00 roll
B-6620	1928-34 Oil pump retainer spring	1.00 ea.	B-17005	Tool Pouch	8.00 ea.
B-6626	1928-34 Oil pump screen cover gasket	.25 ea.	B-17275	1928-48 Speedometer gear case gasket	.40 ea.
B-6631	1928-34 Oil pump shield	12.00 ea.	B-17286	1928-48 Speedometer gear snap ring	.75 ea.
B-6730	1909-38 Oil pan plug with copper gasket	3.00 set	B-17290	1928-48 Speedometer drive gear thrust washer	2.00 ea.
B-6730 M	1909-38 Magnetic oil pan plug	4.00 ea.	B-17529	1930-36 Inside mount wiper arm	4.95 ea.
B-6750	1928-34 Oil dip stick	2.50 ea.	B-35705	1928-32 Open car striker plate	5.50 ea.
B-6781	1932-34 Oil pan gasket set	7.50 set	B-37158	1922-36 Windshield post stud set	5.50 set
B-7040	1928-48 Main drive oil slinger	1.75 ea.	B-41484	1928-34 Rumble lid bumper kit	2.95 set
A-7090 GS	1928-48 Universal housing gasket set	2.25 set	B-41500 S	1928-32 Rumble seat stainless grab handles	43.50 pr.
B-7063	1928-48 Transmission main shaft spacer	.75 ea.	B-41518	1928-34 Rubber bumpers for upper corner of rumble lid and lower corners of deck lid	1.75 set
B-7084	1928-48 Universal joint repair kit	43.50 set	B-42150	1913-48 Footman loop - nickel	1.15 ea.
B-7090	1928-48 Universal joint assembly	99.00 ea.	B-42150 S	1928-48 Footman loop screw set - 8 pcs	1.40 set
B-7090 NB	1928-48 U-joint assembly with needle bearings	99.00 ea.	A-46125 L	1931-40 Spring for twist handle on cabriolet, slant windshield fordor, and victoria	3.25 ea.
B-7118	1928-50 Cluster gear needle bearing (short 2 required)	4.25 ea.	B-46335	1931-32 Hinge pins for slant windshield cars	.90 ea.
B-7121	1928-50 Cluster gear needle bearing (long)	4.25 ea.	B-46335 S	1931-32 Stainless hinge pins for slant windshield cars	1.95 ea.
B-7515	1928-48 Clutch throwout fork	21.50 ea.	B-47106	1930-36 Coupe rear roll down window glass Channel	9.50 ea.
B-7550	1928-40 Clutch disc with woven lining	32.00 ea.	B-79550	1928-32 Closed car windshield hinge gasket	2.75 roll
B-7563 MB	1932 V8 Pressure plate bolts	8.00 set	B-130075 B	1928-55 Sealed beam headlight bulb - 6 volt	13.50 ea.
B-7563 V8	1932 V8 Pressure plate - New	100.00 ea.	B-162592 L6	1928-48 Rubber loop type door check strap 6 in.	2.75 ea.
B-7580	1928-48 Clutch throwout bearing	31.00 ea.	B-162592 L7	1928-48 Rubber loop type door check strap 7 in.	2.75 ea.
B-7600	1928-63 Pilot bearing	4.00 ea.	B-162592 L8	1928-48 Rubber loop type door check strap 8 in.	2.75 ea.
B-8220	1932 Hood hinge retainer - for use with 32 style center hinge	8.35 ea.	B-162592 S	1928-36 Door check arm with adjustable bracket	3.50 ea.
B-8221	1932 Rear center hood hinge retainer	15.50 ea.	B-162592 T	1928-36 Flat type door check strap	6.00 ea.
B-8280	1928-34 Water inlet gasket	.35 ea.	B-702828 A	1928-48 Rubber pads for door check arms	3.25 pr.
B-8280 C	1928-34 Copper water inlet gasket	2.60 ea.	B-702828 B	1928-37 Door check arm with rubber bumpers	6.00 set
B-8507	1932 - 4 Cylinder water pump gasket	.75 ea.	B-702828 CB	1928-34 Rubber bumper for metal check arm	1.75 pr.
B-8530	1928-34 Water pump bearing & sleeve kit	4.50 set	B-704220	1928-36 Rear glass rubber - 6 ft	3.75 roll
			B-773540	1928-41 Quarter windows rubber - 9 ft	4.00 roll

SMITH & JONES ANTIQUE AUTO PARTS

60 WISCONSIN ST, WEST COLUMBIA, SC 29170

PHONE: (803) 822-4141 OR (803) 822-8504

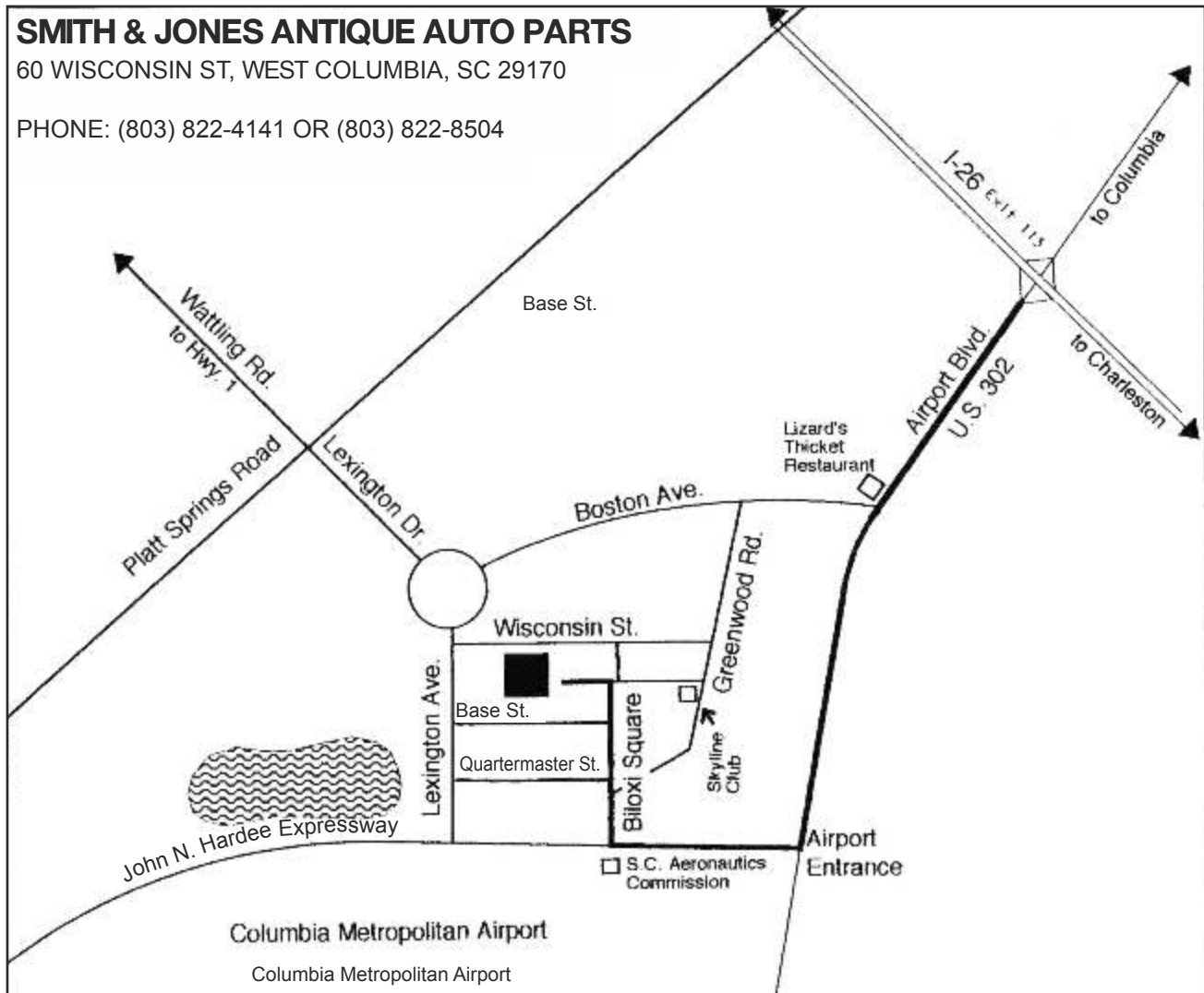

DIRECTIONS: We are located in the area of the Columbia Metropolitan Airport. Get off Interstate-26 at Exit 113, Hwy. 302. Follow Hwy. 302 to the airport entry road which is John Hardee Expressway. Take the right turn onto this road (4 lane hwy) and continue to the second street on the right (Lexington Avenue). Turn right on Lexington Avenue and continue to the second street on the right again. This street is Wisconsin Street. If you get on the traffic circle you have gone too far and will need to turn make your way back. Turn right on Wisconsin Street and go approximately 1 block. Our sign is by the road and we are on the right.

"A" SPECIFICATIONS

Point Gap018-.022
Plug Gap027-.032
Tire Pressure	35 lbs.
Gas Tank	10 gal.
Cooling System	3 gal.
Oil Capacity	5 qts.
Valve Clearance016
Rod Journal	1.500
Main Bearings	1.625
Firing Order	1, 2, 4, 3
Bore	3 7/8"
Stroke	4 1/4"
Compression	76 P.S.I.
Horsepower (SAE Rating)	24.03

Compression Ratio	4.22 to 1
Wheelbase	103 1/2
Cyl. Head Torque	50 Ft. lb.
Engine No. on L.H. Side of Block	
Main Torque	80-100 Ft. lb.
Rods Torque	40-50 Ft. lb.
Battery - 6 volt - Pos. Ground	

MOTOR NUMBERS

1928	5276	.810122
1929	810123	.2742695
1930	2742696	.4237500
1931	4237501	.4830806

SMITH & JONES ANTIQUE AUTO PARTS

60 Wisconsin St., W. Columbia, S.C. 29170

Phone: 803-822-4141 or 803-822-8504

Fax: 803-822-8477

Order Desk: 1-800-422-1928

PRSRT STD
US POSTAGE
PAID
Aberdeen, SD
Permit No. 200

CHANGE SERVICE REQUESTED

TO: